

*City of West Park*

# PROJECT MANUAL

**CITYWIDE SIDEWALK**

---

**RESTORATION AND ADA**

---

**COMPLIANCE – PHASE 2**

---

**CITY COMMISSION**

Mayor: Felicia M. Brunson

Vice Mayor: Brandon Smith

Commissioners: Marvin Price

Joy B. Smith

Dr. Katrina V. Touchstone

**ADMINISTRATION:**

City Manager: W. Ajibola Balogun

City Attorney: Burnadette Norris Weeks

**PREPARED BY:**

City of West Park  
1965 S. State Road 7, West Park, FL 33023

Date:

**MARCH 2024**

## PROJECT SITE



# Table of Contents

SECTION 00200 - INSTRUCTION TO BIDDERS .....  
SECTION 00250 – HUD/CDBG REQUIREMENTS/DAVIS BACON WAGE RATES.....  
SECTION 00300 - PROPOSAL.....  
LIST OF MAJOR SUB CONTRACTORS.....  
SECTION 00350 - CONTINUED QUESTIONARE .....  
SECTION 00410 - BID BOND .....  
SECTION 00500 - CONTRACT AGREEMENT .....  
SECTION 00610 - PERFORMANCE BOND .....  
SECTION 00620 - PAYMENT BOND.....  
SECTION 00650 -CERTIFICATE OF INSURANCE.....  
SECTION 00660 - ACKNOWLEDEMENT OF CONFORMANCE WITH OSHA .....  
SECTION 00665 - TRENCH SAFETY ACT COMPLIANCE .....  
SECTION 00700 - GENERAL CONDITIONS .....  
SECTION 00800 - SUPPLEMENTARY CONDITIONS.....  
SECTION 00900 - ADDENDUM.....  
SECTION 00950 – PROJECT SIGN.....  
SECTION 01000 – GENERAL REQUIREMENTS .....  
SECTION 01700 – CONTRACT CLOSEOUT .....

## ATTACHMENTS

- 1 – SIDEWALK/RAMP REPAIR ZONES
- 2 – TYPICAL SIDEWALK DETAIL
- 3 – SCOPE / TECHNICAL SPECIFICATIONS

## SECTION 00200

### INSTRUCTION TO BIDDERS

#### 1. BID FORM

All bids must be submitted in conformity with the requirements of the Project Manual and on the Bid Form included herewith (Section 300). Also include the Contractor's Questionnaire (Section 00350, with copies if applicable licenses and certifications, latest financial statement, and a list of similar projects completed), and Bid Bond (Section 00410). The **entire** Project Manual and attachments shall be placed in a sealed envelope, marked on the outside with the Contractor's name, address, phone number and Project Name, with the words "SEALED – DO NOT OPEN UNTIL OFFICIAL BID OPENING DATE" clearly marked on the outside. Bids, which contain irregularities of any kind or incomplete bids, may be rejected as informal.

#### 2. BID GUARANTY

The bid must be accompanied by a Bid Guaranty which shall be for an amount equal to five percent (5%) of the proposal and at the option of the bidder may be a certified check, cashier's check, or bid bond. Cash deposits will not be accepted. The Guaranty shall be forfeited if the successful bidder fails to enter into a contract in the form shown within ten (10) working days of the Notice of Award of the Contract. The checks and bid bonds of all except the three lowest bidders will be returned immediately after the opening of bids and the remaining checks or Bid Bonds will be returned within ten (10) working days after the signing of the contract by the successful bidder.

#### 3. TIME FOR RECEIVING BIDS

Bids received prior to the time of opening will be securely kept, unopened. All bids shall be delivered to the City Clerk's Office, 1965 South State Road West Park, FL 33023. No bids will be received after 3:00 P.M. on date of bid opening.

#### 4. QUESTIONS DEADLINE

Deadline for submitting questions is at **3:00 p.m.** on **April 3, 2024**. All questions shall be submitted in writing by letter or fax or email the City Clerk only.

#### 5. WITHDRAWAL OF BIDS

Bids may not be withdrawn for a period of One Hundred and Twenty (120) days from the opening thereof.

#### 6. BIDDERS PRESENT

At or shortly after 3:05 P.M. the bids will be opened and their contents will be made public for the information of the bidders and others properly interested, who may be present either in person or by representative.

#### 7. AWARD OF CONTRACT

The contract will be awarded not later than (4) months from the bid opening date, to the lowest responsible bidder, complying with the conditions of the Notice of Bid Invitation, provided the bid is reasonable, and it is in the interest of the City to accept it. The City however, reserves the right to reject any or all bids.

## 8. QUALIFICATIONS OF BIDDERS

Possession of a valid State of Florida General Contractor's license is required for this project. In the event portions of the work called for in the specifications are to be installed, constructed, or assembled by a sub-contractor or sub-contractors, the bidder must fill in the applicable information requested in the Proposal.

## 9. WARRANTY

Neither the final payment nor any provision of the Contract Documents, nor the use of the equipment by the City shall constitute an acceptance of items found not to comply with stipulations of the Contract Documents. The Contractor shall furnish suitable warranty and guarantee.

## 10. INSURANCE

The bidder to whom a Contract is awarded shall take out and maintain Worker's Compensation Insurance to cover all his/her employees as well as maintain public liability and property damage insurance. See Section 00800, subsection 9 for more details.

## 11. ELIGIBLE BIDDERS

The City reserves the right, before awarding a Contract, to require a Bidder to submit evidence of his/her qualifications, as may be deemed necessary, and consider any evidence available to it of the financial, technical, and other qualifications and abilities of the bidder. The Contract will be awarded only to a Bidder fully qualified to undertake the proposed work. All material or services must meet all applicable Federal, State and Local specifications.

## 12. SAFETY PRECAUTIONS

The Contractor shall maintain suitable and sufficient guards and barriers and, at night, suitable and sufficient safety standards required by Municipal, County, State and Federal ordinances and laws.

## 13. PRE-BID INSPECTION

The Bidder, before submitting a Proposal, is required to visit and examine the site of the work and satisfy himself/herself about the character of the work, any possible difficulties, and all conditions and circumstances which do and may affect the work.

## 14. CONTRACTOR'S QUESTIONNAIRE

Section 00350 contains the form entitled "Contractor's Questionnaire." This form must be completed and submitted as an integral part of the bid package.

## 15. QUALIFICATION OF SURETIES

- A. General: The following requirements shall be met by all surety companies furnishing bid, performance payment or other type of bonds:
- B. Qualifications: As to companies being rated acceptable:
  - 1. The Surety shall be rated as "A" or better as to General Policyholders Rating and Class X or better as to Financial Category by Best's Key Rating Guide, published by Alfred M. Best Company, Inc., of 75 Fulton Street, New York, New York, 10038.

2. The Surety shall be listed on the U.S. Department of the Treasury, Fiscal Service, Bureau of Government Financial Operations, Circular 570, (1982 Revision) entitled, "Companies Holding Certificates of Authority as Acceptable Sureties on Federal Bonds and as Acceptable Reinsuring Companies."
  3. All Surety Companies are subject to approval and may be rejected by the Owner without cause, in the same manner that bids may be rejected.
- C. Limitations: Bonding Limits or Bonding Capacity refer to the limit or amount of Bond acceptable on any one risk.
1. The bonding limit of the Surety shall not exceed ten percent (10%) of the policyholder surplus (capital and surplus) as listed by the aforementioned Best's Key Rating Guide, on any one risk (penalty or amount of any one bond).
- D. Requirements:
1. Policy Holders Surplus is required to be 5 times the amount of any one bond.
  2. The Agent countersigning the bond shall be a resident of Broward County

16. E-VERIFY

All bidders must be authorized to transact business by the State of Florida and must be enrolled in the E-Verify system to confirm the eligibility of all new employees.

**END OF SECTION**

SECTION 00250

HUD/CDBG REQUIREMENTS/DAVIS BACON WAGE RATES

# FEDERAL GRANT

## DEPARTMENT OF HOUSING AND URBAN DEVELOPMENT (HUD)

### A COMMUNITY DEVELOPMENT BLOCK GRANT PROJECT (CDBG)

#### A BOILER PLATE (GUIDE)

FOR

City of West Park

### Sidewalk Restoration and ADA Compliance Phase II

**Project:** The project will restore damaged and deteriorated concrete sidewalk, to comply with barrier free requirements and ADA ramps (with tree root barriers and associated swale restoration where applicable) for various segments. These segments shall include SW 22<sup>nd</sup> Street, SW 23<sup>rd</sup> Street and SW 24<sup>th</sup> Street, in addition to SW 54<sup>th</sup> Avenue from SW 36<sup>th</sup> Street to SW 38<sup>th</sup> Court. This Project will be implemented to retrofit existing sidewalks and ADA ramps to meet ADA compliance.

**Census Tract: 1007 Block Groups 1, 2, 3, 4 & 5, & 1008.02 BG 3**

Table of Contents

**Supplementary Conditions ..... 3**

**Required Documents ..... 4**

**Special Requirements of Broward County Community Development Block Grants Projects ..... 5**

**Certification of Fiscal Year 1988 Restrictions on the Award of Certain Contracts and Sub-Contracts to Foreign Countries ..... 7**

**Certification of Bidder Regarding Equal Employment Opportunity ..... 9**

**Certification by Proposed Subcontractor Regarding Equal Employment Opportunity ..... 10**

**Section 3 Requirements ..... 11**

**§ 135.38 Section 3 Clause ..... 13**

**Bidder’s Initial Section 3 Goals ..... 14**

**Section 3 Estimated Labor Hours and Eligible Jobs Availability Form ..... 15**

**Section 3 Unavailability Certification ..... 16**

**Section 3 Business Concern Certification for Contracting ..... 17**

**Section 3 Business Concern Certification for Contracting Eligibility Guidelines ..... 18**

**Section 3 Worker and Targeted Section 3 Worker Self-Certification ..... 19**

**Section 3 Worker and Targeted Section 3 Worker Self-Certification Eligibility Guidelines ..... 20**

**Section 3 Compliance Report ..... 21**

**Florida Statutes ..... 22**

**Notice to Prospective Subcontractors of Requirement for Certification of Nonsegregated Facilities ..... 23**

**Notice to Labor Unions or Other Organizations of Workers Nondiscrimination in Employment ..... 24**

**Labor Requirements ..... 25**

**29 CFR 1.6 – Use and Effectiveness of Wage Determinations ..... 26**

**Wage Determination(s) Assigned to This Project ..... 29**

**County Business Enterprise ..... 30**

**Certification Regarding Debarment, Suspension, Ineligibility and Voluntary Exclusion ..... 31**

**Appendix I – Certified Payroll ..... 33**

**Appendix II – Statement of Compliance ..... 34**

**Appendix III – Instructions for Completing Payroll Form, WH-347 ..... 35**

**Appendix IV – Federal Labor Standards Provisions ..... 38**

**Appendix V – Sample Project Sign ..... 44**

## **Supplementary Conditions**

### Federal Grants Projects:

By virtue of the fact that funding of this project will be delivered in full or in part from the United States government through: Housing and Urban Development (HUD).

Federal assurances must follow the grant application in addition to any and all supervening assurances set forth in Rules and Regulations published in the Federal Register or CFR.

Clauses, terms or conditions required by federal grantor agency are hereby attached and made a part of this Project Manual.

## Required Documents

**THE FOLLOWING DOCUMENTS SHALL BE COMPLETED AND SUBMITTED WITH THE BID IN ORDER FOR THE BIDDER TO BE CONSIDERED RESPONSIVE:**

1. Bidder's Initial Section 3 Goals - **Page 14**
2. Section 3 Eligible Jobs Availability Form – **Page 15**

**OR**

3. Section 3 Unavailability Certification Form – **Page 16**

**Bidder must submit #2 OR #3 with initial Bid Response, including #1.**

**THE FOLLOWING DOCUMENTS MUST BE COMPLETED AND SUBMITTED PRIOR TO AWARD OF CONTRACT: THESE PAGES ARE PART OF THIS BOILER PLATE**

1. Certification of F. Y. 1988 Restrictions on the Award of Certain Contract and Subcontractors to Foreign Countries – **Pages 7 - 8**
2. Certification of Bidder regarding Equal Employment Opportunities (EEO) - **Page 9**
3. Certification of Proposed Subcontractor regarding Equal Employment Opportunities (EEO) **Page 10**
4. Broward County Section 3 Business Concern Certification for Contracting Form - **Page 17-18**
5. Broward County Section 3 Worker and Targeted Section 3 Worker Form - **Page 19-20**
6. Certification of Non-Segregated Facilities - **Page 24**
7. Notice to Labor Unions or other organizations of Workers Nondiscrimination In employment - **Page 24**
8. Certification regarding Prime Contractor Debarment - **Page 31**
9. Certification regarding Subcontractor(s) Debarment - **Page 32**

## Special Requirements of Broward County Community Development Block Grants Projects

1. Career Source Broward was created by the Interlocal Agreement between the Broward County Commission and the Cities of Fort Lauderdale and Hollywood, November 20, 1973, pursuant to Florida Statutes Chapter 163.01 (7), creating a consortium called the Broward Manpower Council (BMC) to administer employment and training programs in Broward County. The BMC changed its name to the Broward Employment and Training Administration (BETA) in the mid-seventies and more recently adopted the name change, the Workforce One Council, to reflect the expanded scope of its activities in workforce development. There have been continuing resolutions by the Council government members reaffirming the continuation of the interlocal agreement, the last time being in 1996.
2. Career Source Broward's purpose is to provide workforce services to the residents and employers of Broward County; to assist job seekers, economically disadvantaged adults and youth, and dislocated workers to obtain services, skills and employment leading to self-sufficiency.
3. Prime and Subcontract Awards are crucial to the achievement of the success of these services. Therefore, the Prime Contractor shall, and shall require each subcontractor, to fulfill the County requirements by accepting referrals and interviewing eligible laborers and/or trainees as outlined in paragraph (4) below. These eligible laborers and trainees shall fill entry-level positions in the contractor's construction work force and be provided with meaningful training in order to increase the likelihood that they be absorbed into the permanent work force upon completion of the project if the contractor has entry-level positions available.
4. **FOR BIDDERS TO BE RESPONSIVE EACH MUST SUBMIT WITH THEIR BIDS THE BIDDER'S INITIAL SECTION 3 GOALS (PAGE 14). "ELIGIBLE JOBS AVAILABILITY FORM" (PAGE 18) OR THE "UNAVAILABILITY CERTIFICATION" (PAGE 19). NO FORMS WILL BE ACCEPTED AFTER THE BID DUE TIME. NO EXCEPTIONS.**
5. If the successful bidder has eligible job vacancies available, it is the bidder's responsibility to contact Career Source Broward at least two (2) weeks before the commencement of construction in order to obtain job recruitment referrals.
6. To obtain a list of job recruitment referrals the contractor shall contact: CareerSource Broward's Job Order Unit at (954) 677-JOBS (5627) or email jobs@careersourcebroward.com.
7. In the event of the occurrence of any vacancy of eligible job positions at any time during the project, the contractor shall immediately contact CareerSource Broward for new referrals in order to fill those vacancies.
8. In the event that CareerSource Broward is unable to provide referrals in a timely manner, upon notification from the contractor, the contractor shall immediately notify the County who shall provide the contractor with a contact name at the Florida State Employment Service.
9. Contractor shall refer all entry-level job applicants contacting him directly to CareerSource Broward for determination for their eligibility.
10. Contractor may obtain from CareerSource Broward or the Community Development Division information regarding wage subsidies and tax credits as related to the employment to low income persons and residences of enterprise zones.
11. Contractor shall include, or cause to be included, in all subcontracts covering any of the work covered by this contract, the requirements applicable to the Contractor and appearing herein. The requirements for subcontractors only apply to labor and installation subcontracts and exclude materials and supplies subcontracts.

12. Nothing herein shall be construed to require or warrant the award of a bid to a Prime Contractor when it is not the lowest responsive bid when two (2) or more bidders either meet the requirements or certify that no entry level positions are available.
13. Nothing herein shall be construed to require a Prime Contractor to award a subcontract bid if it is not the lowest responsive bid.
14. Nothing herein shall be construed to indicate that a higher level of Jobs Bill Involvement will give the bidder the right of award over other bidders who have agreed to accept referrals from CareerSource Broward. However, when all elements of a bid are substantially equal, the number of entry-level positions available may be used to break ties.

15. **DEFINITIONS**

- a. **Laborer**: Includes at least those workers whose duties are manual or physical in nature, including those workers who use tools or who are performing the work of trade
- b. **Trainee**: Includes a person registered and receiving on-the-job training in a construction occupation under a program which has been approved in advance by the United States Department of Labor and Employment Training Administration as meeting its standards for the on-the-job training programs which have been certified by that Administration.

## **Certification of Fiscal Year 1988 Restrictions on the Award of Certain Contracts and Sub-Contracts to Foreign Countries**

This certification is to verify that the offeror 1) is not a contractor of a foreign country included on the list of countries that discriminate against U.S. firms published by the U.S. Trade Representative (USTR); 2) has not or will not enter into any subcontract with a subcontractor or a foreign country included on the USTR list, and 3) will not provide any product of a country included on the USTR list. These prohibitions also apply to certain products used in these activities, such as affixed equipment, electronics, utilities, and instruments.

Grantees or subgrantees recipients entering into contract for construction, alteration, or repair of any public building or public work project subject to the prohibitions described in this Notice shall include the following provision in all such contracts:

Restriction on Public Building and Public Works Projects.

### **Definitions.**

"Component" as used in this clause, means those articles, materials, and supplies incorporated directly into the product.

"Product", as used in this clause, means construction materials - i.e. articles, materials, and supplies brought to the construction site for incorporation into the public works project, including permanently affixed equipment, instruments, utilities, electronic or other devices, but not including vehicles or construction equipment. In determining the origin of a product BROWARD COUNTY will consider a product as product as produced in a foreign country if it has been assembled or manufactured in the foreign country, or if the cost of the components mine, produced, or manufactured in the foreign country exceed 50 percent of the cost of all its components.

"Contractor or subcontractor of a foreign country", as used in this clause, means any contractor or subcontractor that is a citizen or national of a foreign country or is controlled directly or indirectly by citizens or nationals of a foreign country. A contractor or subcontractor shall be considered to be a citizen or national of a foreign country, or controlled directly or indirectly by citizens or nationals of a foreign country:

1. If 50 percent or more of the contractor or subcontractor is owned by a citizen or national of the foreign country;
2. If the title of 50 percent or more of the stock of the contractor or subcontractor is held subject to trust or fiduciary obligation in favor of citizens or nationals of the foreign country;
3. If 50 percent of more of the voting power in the Contractor or subcontractor is vested in or exercisable on behalf of a citizen or national of the foreign country.
4. In the case or partnership, if any general partner is a citizen of the foreign country;
5. In the case of a corporation, if its president or other chief executive officer or the chairman or its board of directors is a citizen of the foreign country or the majority of any number of its directors necessary to constitute a quorum are citizen of the foreign country or the corporation is organized under the laws of the foreign country or any subdivision, territory, or possession thereof; or
6. In the case of a contractor or subcontractor who is a joint venture, if any participation firm is a citizen or national of a foreign country or meets any of the criteria in subparagraphs (a) (1) through (5) of this clause.

---

Contractor Signature

---

Date

**(a) Restrictions**

The Contractor shall not (1) knowingly enter into any subcontract under this contract with a subcontractor of a foreign country included on the list of countries that discriminate against U.S. firm published by the United States Trade Representation (See Paragraph (c) of this clause), or (2) supply any product under this contract of a country included on the list of foreign countries that discriminate against U.S. firms published by the USTR.

**(b) USTR List**

The USTR published a list in the Federal Register in accordance with section 109(c) of publication L 100-202 where countries can be added or deleted.

**(c) Certification**

The Contractor may rely upon the certification of a prospective subcontractor that is not a subcontractor of a foreign country included on the list of countries that discriminate against U.S. firms published by the USTR and that products supplied by such subcontractor for use on the Federal public works project under this contractor are not products of a foreign country included on the list of foreign countries that discriminate against U.S. firms published by the USTR, unless such Contractor has knowledge that the certification is erroneous.

**(d) Subcontracts**

The Contractor shall incorporate this clause, modified only for the purpose of properly identifying the parties, in all subcontracts. This paragraph (e) shall also be incorporated in all subcontracts.

For additional information see Federal Register Vol.53, No. 53, No. 116, Pages 22569-22573.

## Certification of Bidder Regarding Equal Employment Opportunity

This certification is required pursuant to Executive Order 11246 (30 F.R. 12319-25). The implementing rules and regulations provide that any bids or prospective contractor, or any of their proposed subcontractors, should state as an initial part of the bid or negotiations of the contract whether the contractor has participated in any previous contract or subcontract subject to the equal opportunity clause; and, if so, whether it has filed all compliance reports due under applicable instructions.

Where the Certification indicates that the apparent successful bidder has not filed a compliance report due under applicable instructions, bidder shall submit a compliance report prior to award. **NO CONTRACT SHALL BE AWARDED UNLESS SUCH REPORT IS SUBMITTED.**

### CERTIFICATION BY BIDDER

BIDDER'S NAME: \_\_\_\_\_

ADDRESS: \_\_\_\_\_

1. Bidder has participated in a previous contract or subcontract subject to the Equal Opportunity Clause.

Yes \_\_\_\_\_ No \_\_\_\_\_

2. Compliance reports were required to be filed in connection with such contract or subcontract.

Yes \_\_\_\_\_ No \_\_\_\_\_

3. Bidder has filed all compliance reports due under applicable instructions, including SF. 100.

Yes \_\_\_\_\_ No \_\_\_\_\_

If answer to item 3 is "No", please explain in detail on below or attach a piece of paper if needed.

\_\_\_\_\_  
\_\_\_\_\_  
\_\_\_\_\_  
\_\_\_\_\_  
\_\_\_\_\_

**Certification** – The information above is true and complete to the best of my knowledge and belief.

\_\_\_\_\_  
Print Name

\_\_\_\_\_  
Contractor Signature

\_\_\_\_\_  
Date

**Certification by Proposed Subcontractor Regarding Equal Employment Opportunity**

\_\_\_\_\_  
Name of Prime Contractor

\_\_\_\_\_  
Project No. /Project Name

This certification is required pursuant to Executive Order 11246 (30 F.R. 12319-25). The implementing rules and regulations provide that any bids of prospective contractor, or any of their proposed subcontractors, should state as an initial part of the bid or negotiations of the contract whether the Contractor has participated in any previous contract or subcontract subject to the equal opportunity clause; and, if so, whether it has filed all compliance reports due under applicable instructions.

Where the Certification indicates that the apparent successful bidder has not filed a compliance report due under applicable instructions, bidder shall submit a compliance report prior to award. NO CONTRACT SHALL BE AWARDED UNLESS SUCH REPORT IS SUBMITTED.

**SUBCONTRACTOR’S CERTIFICATION**

SUBCONTRACTOR’S  
NAME:

\_\_\_\_\_

ADDRESS:

\_\_\_\_\_

1. Bidder has participated in a previous contract or subcontract subject to the Equal Opportunity Clause.

Yes \_\_\_\_\_ No \_\_\_\_\_

2. Compliance reports were required to be filed in connection with such contract or subcontract.

Yes \_\_\_\_\_ No \_\_\_\_\_

3. Bidder has filed all compliance reports due under applicable instructions, including SF. 100.

Yes \_\_\_\_\_ No \_\_\_\_\_

If answer to any item is “No”, please explain in detail below or attach a piece of paper if needed.

\_\_\_\_\_  
\_\_\_\_\_  
\_\_\_\_\_  
\_\_\_\_\_  
\_\_\_\_\_  
\_\_\_\_\_

**Certification** – The information above is true and complete to the best of my knowledge and belief.

\_\_\_\_\_  
Print Name

\_\_\_\_\_  
Subcontractor Signature

\_\_\_\_\_  
Date

## **Section 3 Requirements**

### **I. Assurance Statement**

Each applicant, recipient, contractor, and subcontractor on a Section 3 covered project shall sign the attached Section 3 Assurance of Compliance.

### **II. Affirmative Action Plan for Utilization of Project Area Business**

Each applicant, recipient, contractor, and subcontractor preparing to undertake work pursuant to a Section 3 covered contract shall develop and implement an affirmative action plan, which shall:

- (a) Set forth the approximate number and dollar value of all contracts proposed to be awarded to all businesses within each category (type or profession) over the duration of the Section 3 covered project.
- (b) Analyze the information set forth in paragraph (a) and the availability of eligible business concerns within the project area doing business in professions or occupations identified as needed in paragraph (a) and set forth a goal or target number and estimated dollar amount to be awarded to the eligible businesses and entrepreneurs within each category over the duration of the Section 3 covered project.
- (c) Outline the anticipated program to be used to achieve the goals for each business and/or professional category identified. This program should include but not be limited to the following actions:
  - 1. Insertion in bid documents, if any, of the affirmative action plan of the applicant, recipient, contractor, or subcontractor letting the contract; and
  - 2. Identification within the bid documents, if any, of the applicable Section 3 project area.
  - 3. Ensuring that the appropriate business concerns are notified of pending Contractual opportunities either personally or through locally utilized media. (See attached Section 135.38 Clause).

### **III. Bidding and Negotiation Requirements**

Every applicant and recipient shall require prospective contractors for work in connection with Section 3 covered projects to provide, prior to the signing of the contract, a preliminary statement of work force needs (skilled, semi-skilled, unskilled labor and trainees by category) where known, where not known, such information shall be supplied prior to the signing of any contract between contractors and their subcontractors. Consideration should be given to those contractors who will have training and employment opportunities for project area residents.

When a bidding procedure is used to let the contract, the invitation or Solicitation for bids shall advise prospective contractors of the requirements of these regulations.

Plan for utilization of project area business should be inserted in the bid documents by applicant, recipient and contractors. The recipient must have indicated therein that Section 3 applies to the project and what is expected of them. All contractors who bid a job must show in their bid what they will do to implement Section 3. They must in the bid commit themselves to a goal and show what they intend to do to reach that goal. When the bids are opened, they must be evaluated in terms of the bidders' responsiveness to Section 3.

A bid which lacks a commitment to Section 3 or which lacks a goal or plan to reach a goal may be judged nonresponsive.

Applicants, recipients and contractors will ensure that the attached Section 3 Clause and Assurance of Compliance are made a part of all contracts.

In implementing its affirmative action plan, each applicant, recipient, contractor, or subcontractor shall make a good faith effort to achieve its goal or target number and estimated dollar amount of contracts to be awarded to the eligible business and entrepreneurs within category over the duration of the Section 3 covered project.

**IV. Utilization of Lower Income Residents as Trainees & Employees**

Each applicant, recipient, contractor or subcontractor undertaking work in connection with a Section 3 covered project shall make a good faith effort to fill all vacant training and occupational category positions with lower income project area residents.

**V. Section 3 Worker Defined**

Currently meets or when hired met at least one of the following categories as documented within the past five years

- A low or very low-income resident (the worker's income for the previous or annualized calendar year is below the income limit established by HUD); or
- Employed by a Section 3 business concern; or
- A YouthBuild participant.

**VI. Targeted Section 3 Worker Defined**

- Employed by a Section 3 business concern or

Currently meets or when hired met at least one of the following categories as documented within the past five years:

- Living within the service area or the neighborhood of the project, as defined in 24 CFR 75.5
- A YouthBuild participant.

### § 135.38 Section 3 Clause

All Section 3 covered contracts shall include the following clause (referred to as the Section 3 clause):

- A. The work to be performed under this contract is subject to the requirements of Section 3 of the Housing and Urban Development Act of 1968, as amended, 12 U.S.C. 1701u; 42 U.S.C. 3535(d) (Section 3). The purpose of Section 3 is to ensure that employment and other economic opportunities generated by HUD assistance or HUD-assisted projects covered by Section 3, shall, to the greatest extent feasible, be directed to low- and very low-income persons, particularly persons who are recipients of HUD assistance for housing.
- B. The parties to this contract agree to comply with HUD's regulations in 24 CFR 135 and 24 CFR 75 Subpart A – General Provisions, Subpart C - Additional Provisions for Housing and Community Development Financial Assistance and Subpart D -Provisions for Multiple Funding Sources, Recordkeeping, and Compliance, which implement Section 3. As evidenced by their execution of this contract, the parties to this contract certify that they are under no contractual or other impediment that would prevent them from complying with the 24 CFR 135 and 24 CFR 75 Subpart A, Subpart C and Subpart D.
- C. The contractor agrees to send to each labor organization or representative of workers with which the contractor has a collective bargaining agreement or other understanding, if any, a notice advising the labor organization or workers' representative of the contractor's commitments under this Section 3 clause, and will post copies of the notice in conspicuous places at the work site where both employees and applicants for training and employment positions can see the notice. The notice shall describe the Section 3 preference, shall set forth minimum number and job titles subject to hire, availability of apprenticeship and training positions, the qualifications for each; and the name and location of the person(s) taking applications for each of the positions; and the anticipated date the work shall begin.
- D. The contractor agrees to include this Section 3 clause in every subcontract subject to compliance with regulations in 24 CFR 135 and 24 CFR 75 Subpart A, Subpart C and Subpart D and agrees to take appropriate action, as provided in an applicable provision of the subcontract or in this Section 3 clause, upon a finding that the subcontractor is in violation of the regulations in 24 CFR 135 and 24 CFR 75 Subpart A, Subpart C and Subpart D . The contractor will not subcontract with any subcontractor where the contractor has notice or knowledge that the subcontractor has been found in violation of the regulations in 24 CFR 135 and 24 CFR 75 Subpart A, Subpart C and Subpart D .
- E. The contractor will certify that any vacant employment positions, including training positions, that are filled (1) after the contractor is selected but before the contract is executed, and (2) with persons other than those to whom the regulations of 24 CFR 135 and 24 CFR 75 Subpart A, Subpart C and Subpart D, require employment opportunities to be directed, were not filled to circumvent the contractor's obligations under 24 CFR 135 and 24 CFR 75 Subpart A, Subpart C and Subpart D.
- F. Noncompliance with HUD's regulations in 24 CFR 135 and 24 CFR 75 Subpart A, Subpart C and Subpart D may result in sanctions, termination of this contract for default, and debarment or suspension from future HUD assisted contracts.
- G. With respect to work performed in connection with Section 3 covered Indian housing assistance, section 7(b) of the Indian Self-Determination and Education Assistance Act (25 U.S.C. 450e) also applies to the work to be performed under this contract. Section 7(b) requires that to the greatest extent feasible (i) preference and opportunities for training and employment shall be given to Indians, and (ii) preference in the award of contracts and subcontracts shall be given to Indian organizations and Indian-owned Economic Enterprises. Parties to this contract that are subject to the provisions of Section 3 and section 7(b) agree to comply with Section 3 to the maximum extent feasible, but not in derogation of compliance with section 7(b).

**Bidder's Initial Section 3 Goals  
(REQUIRED FORM – BID SUBMISSION)**

1. The Bidder agrees to comply with Section 3 of the Housing and Urban Development Act of 1968.
2. The Bidder agrees to register on the HUD's Section 3 Opportunity Portal, <https://hudapps.hud.gov/OpportunityPortal/> as a Registered Business and certify as a Section 3 Business, if applicable. Bidder will provide documentation of Self Certification submitted and approved via HUD's Section 3 Opportunity Portal.
3. The Bidder agrees to post any job and/or contracting opportunities for this project the HUD's Section 3 Opportunity Portal. Bidder will provide proof of posting job and/or contracting opportunities if awarded.
4. The Bidder agrees to utilize the Section 3 Businesses and Workers listed on the HUD'S Section 3 Opportunity portal as a resource for job and/or contracting opportunities for this project.
5. The Bidder agrees to identify Section 3 Workers and Targeted Section 3 Workers , to the greatest extent feasible, by requesting each onsite worker to complete the Section 3 Self-Certification form.
6. The Bidder agrees, to the greatest extent feasible, to allocate at least, 25% of the total labor hours to identified Section 3 workers during the performance of this contract.
7. The Bidder agrees, to the greatest extent feasible, to allocate at least, 5% of the total labor hours to identified Targeted Section 3 workers during the performance of this contract.

I, \_\_\_\_\_ (please print), as an Authorized Officer of the Bidder, do hereby acknowledge that we are aware of the requirements under Section 3 of the Housing and Urban Development Act of 1968 and will abide by them. We further agree to abide by this Affirmative Action Plan to the greatest extent feasible and realize that should we be awarded the contract, Broward County Community Development Division will monitor the project to assure compliance with this plan.

Company Name: \_\_\_\_\_

Business Address: \_\_\_\_\_

\_\_\_\_\_  
Employer Federal ID#

\_\_\_\_\_  
Print Name

\_\_\_\_\_  
Contractor Signature

\_\_\_\_\_  
Date

**\*\*\* Please Note Section 3 Clause \*\*\***

**Section 3 Estimated Labor Hours and Eligible Jobs Availability Form  
(REQUIRED FORM – BID SUBMISSION)**

\_\_\_\_\_

Name of Contractor                      Contract No.                      Location

	Estimated Labor Hours	% Of Total Labor Hours
Total Job Labor Hours	_____	_____
Section 3 Worker Labor Hours	_____	_____
Targeted Section 3 Worker Labor Hours	_____	_____

<u>Available Entry Level Jobs</u>	<u>Salary Level</u>	<u>Maximum Duration of Employment</u>
1. _____	_____	_____
2. _____	_____	_____
3. _____	_____	_____

The undersigned agrees to accept referrals from Workforce One and to interview referrals for the above-designated positions.

(If incorporated sign here)

ATTEST

\_\_\_\_\_

CONTRACTOR

\_\_\_\_\_

Secretary

By \_\_\_\_\_

(CORPORATE SEAL)  
(If NOT incorporated sign here)

WITNESSES:

\_\_\_\_\_

CONTRACTOR

\_\_\_\_\_

By

**Section 3 Unavailability Certification**

**(REQUIRED FORM – BID SUBMISSION)**

I, \_\_\_\_\_, \_\_\_\_\_ (Title)

of \_\_\_\_\_ (Prime Contractor)

Certify that the undersigned does not have any entry-level jobs available. However, should such jobs become available during the project period, the undersigned agrees to accept referrals from Workforce One to interview these referrals for the available positions.

(If incorporated sign here)

ATTEST

\_\_\_\_\_  
CONTRACTOR

\_\_\_\_\_  
Secretary

By \_\_\_\_\_

(CORPORATE SEAL)

(If NOT incorporated sign here)

WITNESSES:

\_\_\_\_\_  
CONTRACTOR

\_\_\_\_\_  
\_\_\_\_\_

By \_\_\_\_\_

### Section 3 Business Concern Certification for Contracting

**Instructions:** Enter the following information and select the criteria that applies to certify your business' Section 3 Business Concern status.

**Business Information**

Name of Business	
Address of Business	
Name of Business Owner	
Phone Number of Business Owner	
E-mail Address of Business Owner	

**Type of Business (select from the following options):**

- Corporation                     
  Partnership                     
  Sole Proprietorship                     
  Joint Venture

**Select from ONE of the following four options below that applies:**

1.  At least 51 percent of the business is owned and controlled by low- or very low-income persons (refer to income guidelines on Eligibility Guidelines page).
2.  At least 51 percent of the business is owned and controlled by current public housing residents or residents who currently live in Section 8-assisted housing.
3.  Over 75 percent of the labor hours performed for the business over the prior three-month period are performed by Section 3 workers (refer to income guidelines on Eligibility Guidelines page).

**\*\*If any of the first three options applies, the business certifies that it has registered on the Section 3 HUD Opportunity Portal at <https://hudapps.hud.gov/OpportunityPortal/> as a registered Section 3 Business and has attached the certification with this form\*\***

4.  None of the above apply

**Business Concern Affirmation**

I affirm that the above statements (on the frontside of this form) are true, complete, and correct to the best of my knowledge and belief. I understand that businesses who misrepresent themselves as Section 3 business concerns and report false information to Broward County may have their contracts terminated as default and be barred from ongoing and future considerations for contracting opportunities. I hereby certify, under penalty of law, that the following information is correct to the best of my knowledge.

Print Name:	
Signature:	
Date:	

\*Certification expires within six months of date of signature

Information regarding Section 3 Business Concerns can be found at 24 CFR 75.5

### Section 3 Business Concern Certification for Contracting Eligibility Guidelines

The worker's income must be at or below the amount provided below for an individual (household of 1) regardless of actual household size.

Income Limits Category	FY 2023 Income Limits
Very Low Income 50% of median	\$33,600
Low Income 80% of median	\$53,800

#### Section 3 Worker Definition:

Currently meets or when hired met at least one of the following categories as documented within the past five years

- A low or very low-income resident (the worker's income for the previous or annualized calendar year is below the income limit established by HUD); **or**
- Employed by a Section 3 business concern; **or**
- A YouthBuild participant.

#### Targeted Section 3 Worker Definition:

- Employed by a Section 3 business concern **or**

Currently meets or when hired met at least one of the following categories as documented within the past five years:

- Living within the service area or the neighborhood of the project, as defined in 24 CFR 75.5
- A YouthBuild participant.

#### FOR ADMINISTRATIVE USE ONLY

Is the business a Section 3 business concern based upon their certification?	<input type="checkbox"/> YES <input type="checkbox"/> NO
The Business provided certification of registering on the Section 3 Opportunity Portal.	<input type="checkbox"/> YES <input type="checkbox"/> NO

**EMPLOYERS MUST RETAIN THIS FORM IN THEIR SECTION 3 COMPLIANCE FILE FOR FIVE YEARS.**

## Section 3 Worker and Targeted Section 3 Worker Self-Certification

The purpose of HUD's Section 3 program is to provide employment, training and contracting opportunities to low-income individuals, particularly those who are recipients of government assistance for housing or other public assistance programs. **Your response is voluntary, confidential, and has no effect on your employment.**

### Eligibility for Section 3 Worker or Targeted Section 3 Worker Status

A Section 3 worker seeking certification shall self-certify and submit this form to the recipient contractor or subcontractor, that the person is a Section 3 worker or Targeted Section 3 Worker as defined in 24 CFR Part 75.

**Instructions:** Enter/select the appropriate information to confirm your Section 3 worker or Targeted Section 3 Worker status.

Employee Name: \_\_\_\_\_

1. Are you a resident of public housing or a Housing Choice Holder Voucher (Section 8)?  
 YES  NO
2. Are you a resident of the West Park [City] Broward County?  
 YES  NO
3. In the field below, select the amount of individual income you believe you earn on an annual basis.
 

<input type="checkbox"/> Less than \$10,000	<input type="checkbox"/> \$30,001 - \$40,000	<input type="checkbox"/> More than \$60,000
<input type="checkbox"/> \$10,001 - \$20,000	<input type="checkbox"/> \$40,001 - \$50,000	
<input type="checkbox"/> \$20,001 - \$30,000	<input type="checkbox"/> \$50,001 - \$60,000	

Select from **ONE** of the following two options below:

4. I qualify as a:
  - Section 3 Worker (as defined on eligibility guidelines)
  - Targeted Section 3 Worker (as defined on eligibility guidelines)

### Employee Affirmation

I affirm that the above statements (on frontside of this form) are true, complete, and correct to the best of my knowledge and belief. I hereby certify, under penalty of law, that the following information is correct to the best of my knowledge.

Employee Address:	
Employer's Name:	
Date Hired:	
Print Name:	
Signature	
Date:	

### Section 3 Worker and Targeted Section 3 Worker Self-Certification Eligibility Guidelines

The worker's income must be **at or below** the amount provided below for an individual (household of 1) regardless of actual household size.

Income Limits Category	FY 2023 Income Limits
Very Low Income 50% of median	\$33,600
Low Income 80% of median	\$53,800

#### Section 3 Worker Definition:

Currently meets or when hired met at least one of the following categories as documented **within the past five years**

- A low or very low-income resident (the worker's income for the previous or annualized calendar year is below the income limit established by HUD); **or**
- Employed by a Section 3 business concern; **or**
- A YouthBuild participant.

#### Targeted Section 3 Worker Definition:

- Employed by a Section 3 business concern **or**  
Currently meets or when hired met at least one of the following categories as documented within the past five years:
  - Living within the service area or the neighborhood of the project, as defined in 24 CFR 75.5
  - A YouthBuild participant.

### FOR ADMINISTRATIVE USE ONLY

Is the employee a Section 3 worker based upon their self-certification?	<input type="checkbox"/> YES <input type="checkbox"/> NO
Is the employee a Targeted Section 3 worker based upon their self-certification?	<input type="checkbox"/> YES <input type="checkbox"/> NO
Was this an applicant who was hired as a result of the Section 3 project?	<input type="checkbox"/> YES <input type="checkbox"/> NO
If Yes, what is the name of the Company?	
What was the date of hire?	

**EMPLOYERS MUST RETAIN THIS FORM IN THEIR SECTION 3 COMPLIANCE FILE FOR FIVE YEARS.**

**Section 3 Compliance Report**

**CONTRACTOR:** \_\_\_\_\_

**SUBCONTRACTOR:**  
**(If applicable)** \_\_\_\_\_

**PROJECT NAME:** \_\_\_\_\_

**for the MONTH of** \_\_\_\_\_, Year \_\_\_\_\_

This report is required of all contractors/subcontractors having contracts which are funded in whole or in part with Community Development Block Grant funds. This report must be submitted to the Broward County Community Development Division no later than ten (10) days after the end of the reported month.

Please answer the following questions accurately and completely:

1. How many new employees were hired to work on this project during the month? \_\_\_\_\_
2. Of those hired during the month, how many were residents of the Targeted Section 3 Covered Area – 1 mile radius of project area (Broward County)? \_\_\_\_\_
3. Did all employees (new and existing) who worked on this project during this month complete the Section 3 Worker / Targeted Worker Self-Certification Form ?

Yes \_\_\_\_\_ \*\*No \_\_\_\_\_

\*\*If No, please provide documentation and /or detailed explanation of what efforts were made to capture this information from the employees who worked on this project.

I, \_\_\_\_\_ (please print), do hereby certify that the above information is true and correct. I further certify that we have been informed of and understand our responsibilities in utilizing Section 3 Covered Area businesses and residents during performance of our contract.

\_\_\_\_\_  
Signature & Title

\_\_\_\_\_  
Date

## Florida Statutes

Title XLI - Statute of Frauds, Fraudulent Transfers, And General Assignments  
Chapter 725 - Unenforceable Contracts

### **725.06 Construction contracts; limitation on indemnification**

(1) Any portion of any agreement or contract for or in connection with, or any guarantee of or in connection with, any construction, alteration, repair, or demolition of a building, structure, appurtenance, or appliance, including moving and excavating associated therewith, between an owner of real property and an architect, engineer, general contractor, subcontractor, sub-subcontractor, or materialman or any combination thereof wherein any party referred to herein promises to indemnify or hold harmless the other party to the agreement, contract, or guarantee for liability for damages to persons or property caused in whole or in part by any act, omission, or default of the indemnitee arising from the contract or its performance, shall be void and unenforceable unless the contract contains a monetary limitation on the extent of the indemnification that bears a reasonable commercial relationship to the contract and is part of the project specifications or bid documents, if any. Notwithstanding the foregoing, the monetary limitation on the extent of the indemnification provided to the owner of real property by any party in privity of contract with such owner shall not be less than \$1 million per occurrence, unless otherwise agreed by the parties. Indemnification provisions in any such agreements, contracts, or guarantees may not require that the indemnitor indemnify the indemnitee for damages to persons or property caused in whole or in part by any act, omission, or default of a party other than:

(a) The indemnitor;

(b) Any of the indemnitor's contractors, subcontractors, sub-subcontractors, materialmen, or agents of any tier or their respective employees; or

(c) The indemnitee or its officers, directors, agents, or employees. However, such indemnification shall not include claims of, or damages resulting from, gross negligence, or willful, wanton or intentional misconduct of the indemnitee or its officers, directors, agents or employees, or for statutory violation or punitive damages except and to the extent the statutory violation or punitive damages are caused by or result from the acts or omissions of the indemnitor or any of the indemnitor's contractors, subcontractors, sub-subcontractors, materialmen, or agents of any tier or their respective employees.

(2) A construction contract for a public agency or in connection with a public agency's project may require a party to that contract to indemnify and hold harmless the other party to the contract, their officers and employees, from liabilities, damages, losses and costs, including, but not limited to, reasonable attorney's fees, to the extent caused by the negligence, recklessness, or intentional wrongful misconduct of the indemnifying party and persons employed or utilized by the indemnifying party in the performance of the construction contract.

(3) Except as specifically provided in subsection (2), a construction contract for a public agency or in connection with a public agency's project may not require one party to indemnify, defend, or hold harmless the other party, its employees, officers, directors, or agents from any liability, damage, loss, claim, action, or proceeding, and any such contract provision is void as against public policy of this state.

**Notice to Prospective Subcontractors of Requirement for Certification of Nonsegregated Facilities**

- (a) Certification of Non segregated Facilities, as required by the May 1967, Order of the Secretary of Labor (32 F.R. 7439, May 19, 1967) on Elimination of Segregated Facilities (is included in the proposal and must be submitted prior to the award of a federally assisted Construction Contract exceeding \$10,000.00 which is not exempt from the provisions of the Equal Opportunity Clause).
- (b) CONTRACTORS receiving subcontract awards exceeding \$10,000.00 which are not exempt from the provision of the Equal Opportunity Clause will be required to provide for the forwarding of this notice to prospective subcontractors for supplies and construction contracts where the subcontracts exceed \$10,000.00 and are not exempt from the provisions of the Equal Opportunity Clause.
- (c) A Certification for regarding Equal Employment Opportunity is also enclosed with the Bid Proposal Form and should be submitted by the CONTRACTOR with the bid, but must be submitted prior to award.
- (d) The Notice to Labor Unions on the following page shall be forwarded by the CONTRACTOR in accordance with Paragraph 3 of Nondiscrimination Provisions to be included in Federally Assisted Construction Contracts.

**NOTICE TO PROSPECTIVE SUBCONTRACTORS OF REQUIREMENTS FOR CERTIFICATION OF NON-SEGREGATED FACILITIES**

A Certification of Nonsegregated Facilities, as required by the May 9, 1967 Order (32 F.R. 7439 May 19, 1967) on Elimination of Segregated Facilities by the Secretary of Labor must be submitted prior to the award of a subcontract exceeding \$10,000.00 which is not exempt from the provisions of the Equal Opportunity Clause. The Certification may be submitted either for each subcontractor or for all subcontracts during a period (i.e. quarterly, semiannually, or annually).

NOTE: The penalty for making false statements in offers is prescribed in 18 U.S.C. 1001.

---

DATE

---

Signature of Bid (Prospective Contractor)

---

ADDRESS (including zip code)

**Notice to Labor Unions or Other Organizations of Workers Nondiscrimination in Employment**

TO: \_\_\_\_\_  
(Name of Union or Organization of Workers)

The undersigned currently holds contract(s) with  
\_\_\_\_\_  
(Name of Applicant)

Involving funds or credit of the U.S. Government of (a) subcontract (s) with prime contractor holding such contract(s).

You are advised that under the provisions of the above contract(s) or subcontract(s) and in accordance with Executive Order 11246, dated September 4, 1965, the undersigned is obligated not to discriminate against any employee or applicant for employment because of race, color, religion, sex, sexual orientation, gender identity, or national origin. This obligation not to discriminate includes, but is not limited to the following:

HIRING, PLACEMENT, UPGRADING, TRANSFER OR DEMOTION, RECRUITMENT, ADVERTISING OR SOLICITATION FOR EMPLOYMENT, TRAINING DURING EMPLOYMENT, RATES OF PAY OR OTHER FORMS OF COMPENSATION, SELECTION FOR TRAINING INCLUDING APPRENTICESHIP, LAYOFF OR TERMINATION.

This notice is furnished to you pursuant to the provisions of the above contract(s) and Executive Order 11246.

Copies of this notice will be posted by the undersigned in conspicuous places available to employees or applicants for employment.

\_\_\_\_\_  
\_\_\_\_\_  
\_\_\_\_\_  
(Contractor or Subcontractor)

\_\_\_\_\_  
Date

## **Labor Requirements**

### **Applicable to all Prime and Sub-contractors**

Grantees must comply with certain regulations on wage and labor standards. In the case of Davis-Bacon and the Contract Work Hours and Safety Standards Acts, every construction (in the case of residential construction, projects with eight or more units) triggers the requirements.

- Davis-Bacon and Related Acts (40 USC 276(a)-7): Ensures that mechanics and laborers employed in construction work under Federally assisted contracts are paid wages and fringe benefits equal to those that prevail in the locality where the work is performed. This act also provides for the withholding of funds to ensure compliance and excludes from wage requirements apprentices enrolled in bona fide apprenticeship programs.
- Contract Work House and Safety Standards Act (CWHSSA), as amended (40 USC §3701 et seq.; 29 CFR Part 5 ): Provides that mechanics and laborers employed on Federally assisted construction jobs are paid time and one-half for work in excess of 40 hours per week, and provides for the payment of liquidated damages where violations occur. This act also addresses safe and health working conditions.
- Copeland (Anti-Kickback) Act (18 USC §874 and 40 USC §3145; 29 CFR Part 3): Governs the deductions from paychecks that are allowable. Makes it a criminal offense to induce anyone employed on a Federally assisted project to relinquish any compensation to which he/she is entitled and requires all contractors to submit weekly payrolls and statements of compliance.
- Fair Labor Standards Act of 1938. As Amended (26 USC 201.et.seq.): Establishes the basic minimum wage for all work and requires the payment of overtime at the rate of at least time and one-half. It also requires the payment of wages for the entire time that an employee is required or permitted to work and establishes child labor standards.

### **Responsibility of the Prime Contractor**

The principal contractor is responsible for the full compliance of all employers (the contractor, subcontractors and any lower-tier subcontractors) with the labor standards provisions applicable to the project.

### **Administrative Sanctions**

Contractors and/or subcontractors that violate the labor standards provisions may face administrative sanctions imposed by HUD and/or the Department of Labor.

## 29 CFR 1.6 – Use and Effectiveness of Wage Determinations

**Section Number:** 1.6

**Section Name:** Use and effectiveness of wage determinations.

(a)

(1) Project wage determinations initially issued shall be effective for 180 calendar days from the date of such determinations. If such a wage determination is not used in the period of its effectiveness it is void. Accordingly, if it appears that a wage determination may expire between bid opening and contract award (or between initial endorsement under the National Housing Act or the execution of an agreement to enter into a housing assistance payments contract under section 8 of the U.S. Housing Act of 1937, and the start of construction) the agency shall request a new wage determination sufficiently in advance of the bid opening to assure receipt prior thereto. However, when due to unavoidable circumstances a determination expires before award but after bid opening (or before the start of construction, but after initial endorsement under the National Housing Act, or before the start of construction but after the execution of an agreement to enter into a housing assistance payments contract under section 8 of the U.S. Housing Act of 1937), the head of the agency or his or her designee may request the Administrator to extend the expiration date of the wage determination in the bid specifications instead of issuing a new wage determination. Such request shall be supported by a written finding, which shall include a brief statement of the factual support, that the extension of the expiration date of the determination is necessary and proper in the public interest to prevent injustice or undue hardship or to avoid serious impairment in the conduct of Government business. The Administrator will either grant or deny the request for an extension after consideration of all of the circumstances, including an examination to determine if the previously issued rates remain prevailing. If the request for extension is denied, the Administrator will proceed to issue a new wage determination for the project.

(2) General wage determinations issued pursuant to § 1.5(a), notice of which is published on WDOL, shall contain no expiration date.

(b) Contracting agencies are responsible for insuring that only the appropriate wage determination(s) are incorporated in bid solicitations and contract specifications and for designating specifically the work to which such wage determinations will apply. Any question regarding application of wage rate schedules shall be referred to the Administrator, who shall give foremost consideration to area practice in resolving the question.

(c)

(1) Project and general wage determinations may be modified from time to time to keep them current. A modification may specify only the items being changed, or may be in the form of a supersedeas wage determination, which replaces the entire wage determination. Such actions are distinguished from a determination by the Administrator under paragraphs (d), (e) and (f) of this section that an erroneous wage determination has been issued or that the wrong wage determination or wage rate schedule has been utilized by the agency.

(2)

(i) All actions modifying a project wage determination received by the agency before contract award (or the start of construction where there is no contract award) shall be effective except as follows:

(A) In the case of contracts entered into pursuant to competitive bidding procedures, modifications received by the agency less than 10 days before the opening of bids shall be effective unless the agency finds that there is not a reasonable time still available before bid opening, to notify bidders of the modification and a report of the finding is inserted in the contract file. A copy of such report shall be made available to the Administrator upon request. No such report shall be required if the modification is received after bid opening.

(B) In the case of projects assisted under the National Housing Act, modifications shall be effective if received prior to the beginning of construction or the date the mortgage is initially endorsed, whichever occurs first.

(C) In the case of projects to receive housing assistance payments under section 8 of the U.S. Housing Act of 1937, modifications shall be effective if received prior to the beginning of construction or the date the agreement to enter into a housing assistance payments contract is executed, whichever occurs first.

(ii) Modifications to project wage determinations and supersedeas wage determinations shall not be effective after contract award (or after the beginning of construction where there is no contract award).

(iii) Actual written notice of a modification shall constitute receipt.

(3) All actions modifying a general wage determination shall be effective with respect to any project to which the determination applies, if notice of such actions is published before contract award (or the start of construction where there is no contract award), except as follows:

(i) In the case of contracts entered into pursuant to competitive bidding procedures, a modification, notice of which is published less than 10 days before the opening of bids, shall be effective unless the agency finds that there is not a reasonable time still available before bid opening to notify bidders of the modification and a report of the finding is inserted in the contract file. A copy of such report shall be made available to the Administrator upon request. No such report shall be required if notice of the modification is published after bid opening.

(ii) In the case of projects assisted under the National Housing Act, a modification shall be effective if notice of such modification is published prior to the beginning of construction or the date the mortgage is initially endorsed, whichever occurs first.

(iii) In the case of projects to receive housing assistance payments under section 8 of the U.S. Housing Act of 1937, a modification shall be effective if notice of such modification is published prior to the beginning of construction or the date the agreement to enter into a housing assistance payments contract is signed, whichever occurs first.

(iv) If under paragraph (c)(3)(i) of this section the contract has not been awarded within 90 days after bid opening, or if under paragraph (c)(3)(ii) or (iii) of this section construction has not begun within 90 days after initial endorsement or the signing of the agreement to enter into a housing assistance payments contract, any modification, notice of which is published on WDOL prior to award of the contract or the beginning of construction, as appropriate, shall be effective with respect to that contract unless the head of the agency or his or her designee requests and obtains an extension of the 90-day period from the Administrator. Such request shall be supported by a written finding, which shall include a brief statement of the factual support, that the extension is necessary and proper in the public interest to prevent injustice or undue hardship or to avoid serious impairment in the conduct of Government business. The Administrator will either grant or deny the request for an extension after consideration of all the circumstances.

(v) A modification to a general wage determination is "published" within the meaning of this section on the date notice of a modification or a supersedeas wage determination is published on WDOL or on the date the agency receives actual written notice of the modification from the Department of Labor, whichever occurs first. Archived versions of Davis-Bacon and Related Acts wage determinations that are no longer current may be accessed in the "Archived DB WD" database of WDOL for information purposes only. Contracting officers should not use an archived wage determination in a contract action without prior approval of the Department of Labor.

(vi) A supersedeas wage determination or a modification to an applicable general wage determination, notice of which is published after contract award (or after the beginning of construction where there is no contract award) shall not be effective.

(d) Upon his/her own initiative or at the request of an agency, the Administrator may correct any wage determination, without regard to paragraph (c) of this section, whenever the Administrator finds such a wage determination contains clerical errors. Such corrections shall be included in any bid specifications containing the wage determination, or in any on-going contract containing the wage determination in question, retroactively to the start of construction.

(e) Written notification by the Department of Labor prior to the award of a contract (or the start of construction under the National Housing Act, under section 8 of the U.S. Housing Act of 1937, or where there is no contract award) that: (1) There is included in the bidding documents or solicitation the wrong wage determination or the wrong schedule or that (2) a wage determination is withdrawn by the Department of Labor as a result of a decision by the Administrative Review Board, shall be effective immediately without regard to paragraph (c) of this section.

(f) The Administrator may issue a wage determination after contract award or after the beginning of construction if the agency has failed to incorporate a wage determination in a contract required to contain prevailing wage rates determined in accordance with the Davis-Bacon Act, or has used a wage determination which by its terms or the provisions of this part clearly does not apply to the contract. Further, the Administrator may issue a wage determination which shall be applicable to a contract after contract award or after the beginning of construction when it is found that the wrong wage determination has been incorporated in the contract because of an inaccurate description of the project or its location in the agency's request for the wage determination. Under any of the above circumstances, the agency shall either terminate and resolicit the contract with the valid wage determination, or incorporate the valid wage determination retroactive to the beginning of construction through supplemental agreement or through change order, Provided That the contractor is compensated for any increases in wages resulting from such change. The method of incorporation of the valid wage determination, and adjustment in contract price, where appropriate, should be in accordance with applicable procurement law.

(g) If Federal funding or assistance under a statute requiring payment of wages determined in accordance with the Davis-Bacon Act is not approved prior to contract award (or the beginning of construction where there is no contract award), the agency shall request a wage determination prior to approval of such funds. Such a wage determination shall be issued based upon the wages and fringe benefits found to be prevailing on the date of award or the beginning of construction (under the National Housing Act, under section 8 of the U.S. Housing Act of 1937 or where there is no contract award), as appropriate, and shall be incorporated in the contract specifications retroactively to that date, Provided, That upon the request of the head of the agency in individual cases the Administrator may issue such a wage determination to be effective on the date of approval of Federal funds or assistance whenever the Administrator finds that it is necessary and proper in the public interest to prevent injustice or undue hardship, Provided further That the Administrator finds no evidence of intent to apply for Federal funding or assistance prior to contract award or the start of construction, as appropriate.

[48 FR 19533, Apr. 29, 1983, as amended at 50 FR 49823, Dec. 4, 1985]

**Wage Determination(s) Assigned to This Project**

**See “*Exhibit A*”**

## **County Business Enterprise**

COUNTY has established a policy relating to County Business Enterprise (“CBE”) Program participation in all COUNTY Contracts. Although this Agreement does not have assigned CBE Goals or Sheltered Market participation, CONTRACTOR is encouraged to utilize local County business enterprises, where applicable.

COUNTY and CONTRACTOR agree that contractor and vendor awards to CBE are crucial to the achievement of COUNTY’s CBE participation objectives. In an effort to assist COUNTY in achieving its objectives for CBE, CONTRACTOR agrees to make a good faith effort to incorporate CBE participation.

If interested in locating a small business or becoming a small business under the County’s program contact Broward County Small Business Development Division at:

115 South Andrews Ave – Room A640  
Fort Lauderdale, FL 33301  
Phone: 954-357-6400  
Fax: 954-357-6010

Or visit the website: <https://www.broward.org/EconDev/SmallBusiness/>

**Certification Regarding Debarment, Suspension, Ineligibility and Voluntary Exclusion**

1. The prospective primary participant certifies to the best of its knowledge, under penalty of perjury, that, except as noted below, any person associated therewith;
  - a) Are not presently debarred, suspended, proposed for debarment, declared ineligible, or voluntarily excluded from covered transactions by any federal department or agency;
  - b) Have not, within the three (3) year period preceding this certification, been convicted of or had a civil judgment rendered against them for commission of fraud or a criminal offense in connection with obtaining, attempting to obtain, or performing a public (federal, state, or local) transaction or contract under a public transaction, violation of Federal or state antitrust statutes, or commission of embezzlement, theft, forgery, bribery, falsification or destruction of records, making false statements, or receiving stolen property;
  - c) Are not presently indicted for or otherwise criminally or civilly charged by a
    - a. governmental entity (federal, state, or local) with commission of any of the offenses
    - b. listed in subparagraph (1)(b) of this certification; and
  - d) Have not, within the three (3) year period preceding this certification, had one or more
    - a. public transactions (Federal, state, and local) terminated for cause or default.
2. Where the prospective primary participant is unable to certify to any of the statements in this certification, such prospective participant shall attach an explanation to this proposal.
3. If such persons or firms later become aware of any information contradicting the statements of paragraph (1), they will immediately provide that information to Broward County Housing Finance and Community Development Division (Division) in writing.
4. The prospective primary participant agrees by submitting this proposal that, should the proposed covered transaction be entered into, it shall not knowingly enter into any lower tier covered transaction with a person who is debarred, suspended, declared ineligible, or voluntarily excluded from participation in this covered transaction, unless authorized by the Division, department or agency entering into this transaction.
5. The prospective primary participant further agrees by submitting this proposal that it will include the clause titled "Certification Regarding Debarment, Suspension, Ineligibility and Voluntary Exclusion - Lower Tier Covered Transaction," without modification, in all lower tier covered transactions and in all solicitations for lower tier covered transactions.

\_\_\_\_\_  
Signature

\_\_\_\_\_  
Project Name

\_\_\_\_\_  
Title

\_\_\_\_\_  
Project Number

\_\_\_\_\_  
Name of Firm

\_\_\_\_\_  
Address / City, State, Zip

# Certification Regarding Debarment, Suspension, Ineligibility and Voluntary Exclusion

## Lower Tier Covered Transactions

- 1) The prospective lower tier participant certifies, by submission of this document, that neither it nor its principals is presently debarred, suspended, proposed for debarment, declared ineligible, or voluntarily excluded from participation in this transaction by any Federal department or agency.
- 2) Where the prospective lower tier participant is unable to certify to the above statement, the prospective participant shall attach an explanation to this form.

_____ Name	_____ Local Government
_____ Title	_____ CDBG Contract Number
_____ Firm	
_____ Street Address	
_____ City, State, Zip	
_____ Date	

## Appendix I – Certified Payroll

**U.S. Department of Labor**  
Wage and Hour Division

### PAYROLL

(For Contractor's Optional Use; See Instructions at [www.dol.gov/whd/forms/wh347instr.htm](http://www.dol.gov/whd/forms/wh347instr.htm))



*Persons are not required to respond to the collection of information unless it displays a currently valid OMB control number.*

NAME OF CONTRACTOR <input type="checkbox"/> OR SUBCONTRACTOR <input type="checkbox"/>	ADDRESS	OMB No.: 1235-0008 Expires: 07/31/2024
PAYROLL NO. <input type="text"/>	FOR WEEK ENDING <input type="text"/>	PROJECT AND LOCATION <input type="text"/>
		PROJECT OR CONTRACT NO. <input type="text"/>

(1) NAME AND INDIVIDUAL IDENTIFYING NUMBER (e.g., LAST FOUR DIGITS OF SOCIAL SECURITY NUMBER) OF WORKER	(2) NO. OF WITHHELD EMPLOYEES	(3) WORK CLASSIFICATION	OT OR ST.	(4) DAY AND DATE							(5) TOTAL HOURS	(6) RATE OF PAY	(7) GROSS AMOUNT EARNED	(8) DEDUCTIONS					(9) NET WAGES PAID FOR WEEK
				HOURS WORKED EACH DAY										FICA	WITH-HOLDING TAX	OTHER	TOTAL DEDUCTIONS		
				S	S	S	S	S	S	S									
			O																
			O																
			S																
			O																
			O																
			S																
			O																
			S																
			O																
			S																

While completion of Form WH-347 is optional, it is mandatory for covered contractors and subcontractors performing work on Federally financed or assisted construction contracts to respond to the information collection contained in 29 C.F.R. §§ 3.3, 5.5(a). The Copeland Act (40 U.S.C. § 3145) contractors and subcontractors performing work on Federally financed or assisted construction contracts to "furnish weekly a statement with respect to the wages paid each employee during the preceding week." U.S. Department of Labor (DOL) regulations at 29 C.F.R. § 5.5(a)(3)(i) require contractors to submit weekly a copy of all payrolls to the Federal agency contracting for or financing the construction project, accompanied by a signed "Statement of Compliance" indicating that the payrolls are correct and complete and that each laborer or mechanic has been paid not less than the proper Davis-Bacon prevailing wage rate for the work performed. DOL and federal contracting agencies receiving this information review the information to determine that employees have received legally required wages and fringe benefits.

**Public Burden Statement**

We estimate that it will take an average of 55 minutes to complete this collection, including time for reviewing instructions, searching existing data sources, gathering and maintaining the data needed, and completing and reviewing the collection of information. If you have any comments regarding these estimates or any other aspect of this collection, including suggestions for reducing this burden, send them to the Administrator, Wage and Hour Division, U.S. Department of Labor, Room S3502, 200 Constitution Avenue, N.W. Washington, D.C. 20210

## Appendix II – Statement of Compliance

Date   
 I,    
 (Name of Signatory Party) (Title)

do hereby state:

(1) That I pay or supervise the payment of the persons employed by  on the  (Contractor or Subcontractor); that during the payroll period commencing on the  (Building or Work); ; day of , , and ending the  day of ,  all persons employed on said project have been paid the full weekly wages earned, that no rebates have been or will be made either directly or indirectly to or on behalf of said  (Contractor or Subcontractor) from the full

weekly wages earned by any person and that no deductions have been made either directly or indirectly from the full wages earned by any person, other than permissible deductions as defined in Regulations, Part 3 (29 C.F.R. Subtitle A), issued by the Secretary of Labor under the Copeland Act, as amended (48 Stat. 948, 63 Stat. 108, 72 Stat. 967; 76 Stat. 357; 40 U.S.C. § 3145), and described below:

(2) That any payrolls otherwise under this contract required to be submitted for the above period are correct and complete; that the wage rates for laborers or mechanics contained therein are not less than the applicable wage rates contained in any wage determination incorporated into the contract; that the classifications set forth therein for each laborer or mechanic conform with the work he performed.

(3) That any apprentices employed in the above period are duly registered in a bona fide apprenticeship program registered with a State apprenticeship agency recognized by the Bureau of Apprenticeship and Training, United States Department of Labor, or if no such recognized agency exists in a State, are registered with the Bureau of Apprenticeship and Training, United States Department of Labor.

(4) That:  
 (a) WHERE FRINGE BENEFITS ARE PAID TO APPROVED PLANS, FUNDS, OR PROGRAMS

— in addition to the basic hourly wage rates paid to each laborer or mechanic listed in the above referenced payroll, payments of fringe benefits as listed in the contract have been or will be made to appropriate programs for the benefit of such employees, except as noted in section 4(c) below.

(b) WHERE FRINGE BENEFITS ARE PAID IN CASH

— Each laborer or mechanic listed in the above referenced payroll has been paid, as indicated on the payroll, an amount not less than the sum of the applicable basic hourly wage rate plus the amount of the required fringe benefits as listed in the contract, except as noted in section 4(c) below.

(c) EXCEPTIONS

EXCEPTION (CRAFT)	EXPLANATION
REMARKS:	
NAME AND TITLE	SIGNATURE
THE WILLFUL FALSIFICATION OF ANY OF THE ABOVE STATEMENTS MAY SUBJECT THE CONTRACTOR OR SUBCONTRACTOR TO CIVIL OR CRIMINAL PROSECUTION. SEE SECTION 1001 OF TITLE 18 AND SECTION 3729 OF TITLE 31 OF THE UNITED STATES CODE.	

## Appendix III – Instructions for Completing Payroll Form, WH-347

OMB Control No. 1235-0008, Expires 07/31/2024.

**General:** Form WH-347 has been made available for the convenience of contractors and subcontractors required by their Federal or Federally-aided construction-type contracts and subcontracts to submit weekly payrolls. Properly filled out, this form will satisfy the requirements of Regulations, Parts 3 and 5 (29 C.F.R., Subtitle A), as to payrolls submitted in connection with contracts subject to the Davis-Bacon and related Acts.

While completion of Form WH-347 is optional, it is mandatory for covered contractors and subcontractors performing work on Federally financed or assisted construction contracts to respond to the information collection contained in 29 C.F.R. §§ 3.3, 5.5(a). The Copeland Act (40 U.S.C. § 3145) requires contractors and subcontractors performing work on Federally financed or assisted construction contracts to "furnish weekly a statement with respect to the wages paid each employee during the preceding week." U.S. Department of Labor (DOL) Regulations at 29 C.F.R. § 5.5(a)(3)(ii) require contractors to submit weekly a copy of all payrolls to the Federal agency contracting for or financing the construction project, accompanied by a signed "Statement of Compliance" indicating that the payrolls are correct and complete and that each laborer or mechanic has been paid not less than the proper Davis-Bacon prevailing wage rate for the work performed. DOL and federal contracting agencies receiving this information review the information to determine that employees have received legally required wages and fringe benefits.

Under the Davis-Bacon and related Acts, the contractor is required to pay not less than prevailing wage, including fringe benefits, as predetermined by the Department of Labor. The contractor's obligation to pay fringe benefits may be met either by payment of the fringe benefits to bona fide benefit plans, funds or programs or by making payments to the covered workers (laborers and mechanics) as cash in lieu of fringe benefits.

This payroll provides for the contractor to show on the face of the payroll all monies to each worker, whether as basic rates or as cash in lieu of fringe benefits, and provides for the contractor's representation in the statement of compliance on the payroll (as shown on page 2) that he/she is paying for fringe benefits required by the contract and not paid as cash in lieu of fringe benefits. Detailed instructions concerning the preparation of the payroll follow:

**Contractor or Subcontractor:** Fill in your firm's name and check appropriate box.

**Address:** Fill in your firm's address.

**Payroll No.:** Beginning with the number "1", list the payroll number for the submission.

**For Week Ending:** List the workweek ending date.

**Project and Location:** Self-explanatory.

**Project or Contract No.:** Self-explanatory.

**Column 1 - Name and Individual Identifying Number of Worker:** Enter each worker's full name and an individual identifying number (e.g., last four digits of worker's social security number) on each weekly payroll submitted.

**Column 2 - No. of Withholding Exemptions:** This column is merely inserted for the employer's convenience and is not a requirement of Regulations, Part 3 and 5.

**Column 3 - Work Classifications:** List classification descriptive of work actually performed by each laborer or mechanic. Consult classification and minimum wage schedule set forth in contract specifications. If additional classifications are deemed necessary, see Contracting Officer or Agency representative. An individual may be

shown as having worked in more than one classification provided an accurate breakdown or hours worked in each classification is maintained and shown on the submitted payroll by use of separate entries.

**Column 4 - Hours worked:** List the day and date and straight time and overtime hours worked in the applicable boxes. On all contracts subject to the Contract Work Hours Standard Act, enter hours worked in excess of 40 hours a week as "overtime".

**Column 5 - Total:** Self-explanatory

**Column 6 - Rate of Pay (Including Fringe Benefits):** In the "straight time" box for each worker, list the actual hourly rate paid for straight time worked, plus cash paid in lieu of fringe benefits paid. When recording the straight time hourly rate, any cash paid in lieu of fringe benefits may be shown separately from the basic rate. For example, "\$12.25/.40" would reflect a \$12.25 base hourly rate plus \$0.40 for fringe benefits. This is of assistance in correctly computing overtime. See "Fringe Benefits" below. When overtime is worked, show the overtime hourly rate paid plus any cash in lieu of fringe benefits paid in the "overtime" box for each worker; otherwise, you may skip this box. See "Fringe Benefits" below. Payment of not less than time and one-half the basic or regular rate paid is required for overtime under the Contract Work Hours Standard Act of 1962 if the prime contract exceeds \$100,000. In addition to paying no less than the predetermined rate for the classification which an individual works, the contractor must pay amounts predetermined as fringe benefits in the wage decision made part of the contract to approved fringe benefit plans, funds or programs or shall pay as cash in lieu of fringe benefits. See "FRINGE BENEFITS" below.

**Column 7 - Gross Amount Earned:** Enter gross amount earned on this project. If part of a worker's weekly wage was earned on projects other than the project described on this payroll, enter in column 7 first the amount earned on the Federal or Federally assisted project and then the gross amount earned during the week on all projects, thus "\$163.00/\$420.00" would reflect the earnings of a worker who earned \$163.00 on a Federally assisted construction project during a week in which \$420.00 was earned on all work.

**Column 8 - Deductions:** Five columns are provided for showing deductions made. If more than five deduction are involved, use the first four columns and show the balance deductions under "Other" column; show actual total under "Total Deductions" column; and in the attachment to the payroll describe the deduction(s) contained in the "Other" column. All deductions must be in accordance with the provisions of the Copeland Act Regulations, 29 C.F.R., Part 3. If an individual worked on other jobs in addition to this project, show actual deductions from his/her weekly gross wage, and indicate that deductions are based on his gross wages.

**Column 9 - Net Wages Paid for Week:** Self-explanatory.

**Totals** - Space has been left at the bottom of the columns so that totals may be shown if the contractor so desires.

**Statement Required by Regulations, Parts 3 and 5:** While the "statement of compliance" need not be notarized, the statement (on page 2 of the payroll form) is subject to the penalties provided by 18 U.S.C. § 1001, namely, a fine, possible imprisonment of not more than 5 years, or both. Accordingly, the party signing this statement should have knowledge of the facts represented as true.

**Items 1and 2:** Space has been provided between items (1) and (2) of the statement for describing any deductions made. If all deductions made are adequately described in the "Deductions" column above, state "See Deductions column in this payroll." See "FRINGE BENEFITS" below for instructions concerning filling out paragraph 4 of the statement.

**Item 4 FRINGE BENEFITS - Contractors who pay all required fringe benefits:** If paying all fringe benefits to approved plans, funds, or programs in amounts not less than were determined in the applicable wage decision of the Secretary of Labor, show the basic cash hourly rate and overtime rate paid to each worker on the face of the payroll and check paragraph 4(a) of the statement on page 2 of the WH-347 payroll form to indicate the payment. Note any exceptions in section 4(c).

**Contractors who pay no fringe benefits:** If not paying all fringe benefits to approved plans, funds, or programs in amounts of at least those that were determined in the applicable wage decision of the Secretary of Labor, pay any remaining fringe benefit amount to each laborer and mechanic and insert in the "straight time" of the "Rate of Pay" column of the payroll an amount not less than the predetermined rate for each classification plus the amount of fringe benefits determined for each classification in the application wage decision. Inasmuch as it is not necessary to pay time and a half on cash paid in lieu of fringe benefits, the overtime rate shall be not less than the sum of the basic predetermined rate, plus the half time premium on basic or regular rate, plus the required cash in lieu of fringe benefits at the straight time rate. In addition, check paragraph 4(b) of the statement on page 2 the payroll form to indicate the payment of fringe benefits in cash directly to the workers. Note any exceptions in section 4(c).

### **Use of Section 4(c), Exceptions**

Any contractor who is making payment to approved plans, funds, or programs in amounts less than the wage determination requires is obliged to pay the deficiency directly to the covered worker as cash in lieu of fringe benefits. Enter any exceptions to section 4(a) or 4(b) in section 4(c). Enter in the Exception column the craft, and enter in the Explanation column the hourly amount paid each worker as cash in lieu of fringe benefits and the hourly amount paid to plans, funds, or programs as fringe benefits. The contractor must pay an amount not less than the predetermined rate plus cash in lieu of fringe benefits as shown in section 4(c) to each such individual for all hours worked (unless otherwise provided by applicable wage determination) on the Federal or Federally assisted project. Enter the rate paid and amount of cash paid in lieu of fringe benefits per hour in column 6 on the payroll. See paragraph on "Contractors who pay no fringe benefits" for computation of overtime rate.

**Public Burden Statement:** We estimate that it will take an average of 55 minutes to complete this collection of information, including time for reviewing instructions, searching existing data sources, gathering and maintaining the data needed, and completing and reviewing the collection of information. If you have any comments regarding these estimates or any other aspect of this collection of information, including suggestions for reducing this burden, send them to the Administrator, Wage and Hour Division, U.S. Department of Labor, Room S3502, 200 Constitution Avenue, N.W., Washington, D.C. 20210.

## Appendix IV – Federal Labor Standards Provisions

### Applicability

The Project or Program to which the construction work covered by this contract pertains is being assisted by the United States of America and the following Federal Labor Standards Provisions are included in this Contract pursuant to the provisions applicable to such Federal assistance.

**A. 1. (i) Minimum Wages.** All laborers and mechanics employed or working upon the site of the work, will be paid unconditionally and not less often than once a week, and without subsequent deduction or rebate on any account (except such payroll deductions as are permitted by regulations issued by the Secretary of Labor under the Copeland Act (29 CFR Part 3), the full amount of wages and bona fide fringe benefits (or cash equivalents thereof) due at time of payment computed at rates not less than those contained in the wage determination of the Secretary of Labor which is attached hereto and made a part hereof, regardless of any contractual relationship which may be alleged to exist between the contractor and such laborers and mechanics. Contributions made or costs reasonably anticipated for bona fide fringe benefits under Section I(b)(2) of the Davis-Bacon Act on behalf of laborers or mechanics are considered wages paid to such laborers or mechanics, subject to the provisions of 29 CFR 5.5(a)(1)(iv); also, regular contributions made or costs incurred for more than a weekly period (but not less often than quarterly) under plans, funds, or programs, which cover the particular weekly period, are deemed to be constructively made or incurred during such weekly period. Such laborers and mechanics shall be paid the appropriate wage rate and fringe benefits on the wage determination for the classification of work actually performed, without regard to skill, except as provided in 29 CFR 5.5(a)(4). Laborers or mechanics performing work in more than one classification may be compensated at the rate specified for each classification for the time actually worked therein: Provided, That the employer's payroll records accurately set forth the time spent in each classification in which work is performed. The wage determination (including any additional classification and wage rates conformed under 29 CFR 5.5(a)(1)(ii) and the Davis-Bacon poster (WH1321) shall be posted at all times by the contractor and its subcontractors at the site of the work in a prominent and accessible, place where it can be easily seen by the workers.

(ii) (a) Any class of laborers or mechanics which is not listed in the wage determination and which is to be employed under the contract shall be classified in conformance with the wage determination. HUD shall approve an additional classification and wage rate and fringe benefits therefor only when the following criteria have been met:

(1) The work to be performed by the classification requested is not performed by a classification in the wage determination; and

(2) The classification is utilized in the area by the construction industry; and

(3) The proposed wage rate, including any bona fide fringe benefits, bears a reasonable relationship to the wage rates contained in the wage determination.

(b) If the contractor and the laborers and mechanics to be employed in the classification (if known), or their representatives, and HUD or its designee agree on the classification and wage rate (including the amount designated for fringe benefits where appropriate), a report of the action taken shall be sent by HUD or its designee to the Administrator of the Wage and Hour Division, Employment Standards Administration, U.S. Department of Labor, Washington, D.C. 20210. The Administrator, or an authorized representative, will approve, modify, or disapprove every additional classification action within 30 days of receipt and so advise HUD or its designee or will notify HUD or its designee within the 30-day period that additional time is necessary. (Approved by the Office of Management and Budget under OMB control number 1215- 0140.)

(c) In the event the contractor, the laborers or mechanics to be employed in the classification or their representatives, and HUD or its designee do not agree on the proposed classification and wage rate (including the amount designated for fringe benefits, where appropriate), HUD or its designee shall refer the questions, including the views of all interested parties and the recommendation of HUD or its designee, to the Administrator for determination. The Administrator, or an authorized representative, will issue a determination within 30 days of receipt and so advise HUD or its designee or will notify HUD or its designee within the 30-day period that additional time is necessary. (Approved by the Office of Management and Budget under OMB Control Number 1215-0140.)

(d) The wage rate (including fringe benefits where appropriate) determined pursuant to subparagraphs (1)(ii)(b) or (c) of this paragraph, shall be paid to all workers performing work in the classification under this contract from the first day on which work is performed in the classification.

(iii) Whenever the minimum wage rate prescribed in the contract for a class of laborers or mechanics includes a fringe benefit which is not expressed as an hourly rate, the contractor shall either pay the benefit as stated in the wage determination or shall pay another bona fide fringe benefit or an hourly cash equivalent thereof.

(iv) If the contractor does not make payments to a trustee or other third person, the contractor may consider as part of the wages of any laborer or mechanic the amount of any costs reasonably anticipated in providing bona fide fringe benefits under a plan or program, Provided, That the Secretary of Labor has found, upon the written request of the contractor, that the applicable standards of the Davis Bacon Act have been met. The Secretary of Labor may require the contractor to set aside in a separate account assets for the meeting of obligations under the plan or program. (Approved by the Office of Management and Budget under OMB Control Number 1215-0140.)

**2. Withholding.** HUD or its designee shall upon its own action or upon written request of an authorized representative of the Department of Labor withhold or cause to be withheld from the contractor under this contract or any other Federal contract with the same prime contractor, or any other Federally-assisted contract subject to Davis-Bacon prevailing wage requirements, which is held by the same prime contractor so much of the accrued payments or advances as may be considered necessary to pay laborers and mechanics, including apprentices, trainees and helpers, employed by the contractor or any subcontractor the full amount of wages required by the contract. In the event of failure to pay any laborer or mechanic, including any apprentice, trainee or helper, employed or working on the site of the work, all or part of the wages required by the contract, HUD or its designee may, after written notice to the contractor, sponsor, applicant, or owner, take such action as may be necessary to cause the suspension of any further payment, advance, or guarantee of funds until such violations have ceased. HUD or its designee may, after written notice to the contractor, disburse such amounts withheld for and on account of the contractor or subcontractor to the respective employees to whom they are due. The Comptroller General shall make such disbursements in the case of direct Davis-Bacon Act contracts.

**3. (i) Payrolls and basic records.** Payrolls and basic records relating thereto shall be maintained by the contractor during the course of the work preserved for a period of three years thereafter for all laborers and mechanics working at the site of the work. Such records shall contain the name, address, and social security number of each such worker, his or her correct classification, hourly rates of wages paid (including rates of contributions or costs anticipated for bona fide fringe benefits or cash equivalents thereof of the types described in Section I(b)(2)(B) of the Davis-bacon Act), daily and weekly number of hours worked, deductions made and actual wages paid. Whenever the Secretary of Labor has found under 29 CFR 5.5 (a)(1)(iv) that the wages of any laborer or mechanic include the amount of any costs reasonably anticipated in providing benefits under a plan or program described in Section I(b)(2)(B) of the Davis Bacon Act, the contractor shall maintain records which show that the commitment to provide such benefits is enforceable, that the plan or program is financially responsible, and that the plan or program has been communicated in writing to the laborers or mechanics affected, and records which show the costs anticipated or the actual cost incurred in providing such benefits. Contractors employing apprentices or trainees under approved programs shall maintain written evidence of the registration of apprenticeship programs and certification of trainee programs, the registration of the apprentices and trainees, and the ratios and wage rates prescribed in the applicable programs. (Approved by the Office of Management and Budget under OMB Control Numbers 1215-0140 and 1215-0017.)

**(ii) (a)** The contractor shall submit weekly for each week in which any contract work is performed a copy of all payrolls to HUD or its designee if the agency is a party to the contract, but if the agency is not such a party, the contractor will submit the payrolls to the applicant sponsor, or owner, as the case may be, for transmission to HUD or its designee. The payrolls submitted shall set out accurately and completely all of the information required to be maintained under 29 CFR 5.5(a)(3)(i) except that full social security numbers and home addresses shall not be included on weekly transmittals. Instead the payrolls shall only need to include an individually identifying number for each employee (e.g., the last four digits of the employee's social security number). The required weekly payroll information may be submitted in any form desired. Optional Form WH-347 is available for this purpose from the Wage and Hour Division Web site at <http://www.dol.gov/esa/whd/forms/wh347instr.htm> or its successor site. The prime contractor is responsible for the submission of copies of payrolls by all subcontractors. Contractors and subcontractors shall maintain the full social security number and current address of each covered worker, and shall provide them upon request to HUD or its designee if the agency is a party to the

contract, but if the agency is not such a party, the contractor will submit the payrolls to the applicant sponsor, or owner, as the case may be, for transmission to HUD or its designee, the contractor, or the Wage and Hour Division of the Department of Labor for purposes of an investigation or audit of compliance with prevailing wage requirements. It is not a violation of this subparagraph for a prime contractor to require a subcontractor to provide addresses and social security numbers to the prime contractor for its own records, without weekly submission to HUD or its designee. (Approved by the Office of Management and Budget under OMB Control Number 1215-0149.)

(b) Each payroll submitted shall be accompanied by a "Statement of Compliance," signed by the contractor or subcontractor or his or her agent who pays or supervises the payment of the persons employed under the contract and shall certify the following:

(1) That the payroll for the payroll period contains the information required to be provided under 29 CFR 5.5(a)(3)(ii), the appropriate information is being maintained under 29 CFR 5.5(a)(3)(i), and that such information is correct and complete;

(2) That each laborer or mechanic (including each helper, apprentice, and trainee) employed on the contract during the payroll period has been paid the full weekly wages earned, without rebate, either directly or indirectly, and that no deductions have been made either directly or indirectly from the full wages earned, other than permissible deductions as set forth in 29 CFR Part 3;

(3) That each laborer or mechanic has been paid not less than the applicable wage rates and fringe benefits or cash equivalents for the classification of work performed, as specified in the applicable wage determination incorporated into the contract.

(c) The weekly submission of a properly executed certification set forth on the reverse side of Optional Form WH-347 shall satisfy the requirement for submission of the "Statement of Compliance" required by subparagraph A.3.(ii)(b).

(d) The falsification of any of the above certifications may subject the contractor or subcontractor to civil or criminal prosecution under Section 1001 of Title 18 and Section 231 of Title 31 of the United States Code.

(iii) The contractor or subcontractor shall make the records required under subparagraph A.3.(i) available for inspection, copying, or transcription by authorized representatives of HUD or its designee or the Department of Labor, and shall permit such representatives to interview employees during working hours on the job. If the contractor or subcontractor fails to submit the required records or to make them available, HUD or its designee may, after written notice to the contractor, sponsor, applicant or owner, take such action as may be necessary to cause the suspension of any further payment, advance, or guarantee of funds. Furthermore, failure to submit the required records upon request or to make such records available may be grounds for debarment action pursuant to 29 CFR 5.12. 4.

#### **4. Apprentices and Trainees.**

**(i) Apprentices.** Apprentices will be permitted to work at less than the predetermined rate for the work they performed when they are employed pursuant to and individually registered in a bona fide apprenticeship program registered with the U.S. Department of Labor, Employment and Training Administration, Office of Apprenticeship Training, Employer and Labor Services, or with a State Apprenticeship Agency recognized by the Office, or if a person is employed in his or her first 90 days of probationary employment as an apprentice in such an apprenticeship program, who is not individually registered in the program, but who has been certified by the Office of Apprenticeship Training, Employer and Labor Services or a State Apprenticeship Agency (where appropriate) to be eligible for probationary employment as an apprentice. The allowable ratio of apprentices to journeymen on the job site in any craft classification shall not be greater than the ratio permitted to the contractor as to the entire work force under the registered program. Any worker listed on a payroll at an apprentice wage rate, who is not registered or otherwise employed as stated above, shall be paid not less than the applicable wage rate on the wage determination for the classification of work actually performed. In addition, any apprentice performing work on the job site in excess of the ratio permitted under the registered program shall be paid not less than the applicable wage rate on the wage determination for the work actually performed. Where a contractor is performing construction on a project in a locality other than that in which its program is registered, the ratios and wage rates (expressed in percentages of the journeyman's hourly rate) specified in the contractor's or subcontractor's registered program shall be observed. Every apprentice must be paid at not less than the rate specified in the registered program for the apprentice's level of progress, expressed as a percentage of the journeymen hourly rate specified in the applicable wage determination. Apprentices shall be paid fringe benefits in accordance with the provisions of the apprenticeship program. If the apprenticeship program does not specify

fringe benefits, apprentices must be paid the full amount of fringe benefits listed on the wage determination for the applicable classification. If the Administrator determines that a different practice prevails for the applicable apprentice classification, fringes shall be paid in accordance with that determination. In the event the Office of Apprenticeship Training, Employer and Labor Services, or a State Apprenticeship Agency recognized by the Office, withdraws approval of an apprenticeship program, the contractor will no longer be permitted to utilize apprentices at less than the applicable predetermined rate for the work performed until an acceptable program is approved.

**(ii) Trainees.** Except as provided in 29 CFR 5.16, trainees will not be permitted to work at less than the predetermined rate for the work performed unless they are employed pursuant to and individually registered in a program which has received prior approval, evidenced by formal certification by the U.S. Department of Labor, Employment and Training Administration. The ratio of trainees to journeymen on the job site shall not be greater than permitted under the plan approved by the Employment and Training Administration. Every trainee must be paid at not less than the rate specified in the approved program for the trainee's level of progress, expressed as a percentage of the journeyman hourly rate specified in the applicable wage determination. Trainees shall be paid fringe benefits in accordance with the provisions of the trainee program. If the trainee program does not mention fringe benefits, trainees shall be paid the full amount of fringe benefits listed on the wage determination unless the Administrator of the Wage and Hour Division determines that there is an apprenticeship program associated with the corresponding journeyman wage rate on the wage determination which provides for less than full fringe benefits for apprentices. Any employee listed on the payroll at a trainee rate who is not registered and participating in a training plan approved by

the Employment and Training Administration shall be paid not less than the applicable wage rate on the wage determination for the work actually performed. In addition, any trainee performing work on the job site in excess of the ratio permitted under the registered program shall be paid not less than the applicable wage rate on the wage determination for the work actually performed. In the event the Employment and Training Administration withdraws approval of a training program, the contractor will no longer be permitted to utilize trainees at less than the applicable predetermined rate for the work performed until an acceptable program is approved.

**(iii) Equal employment opportunity.** The utilization of apprentices, trainees and journeymen under 29 CFR Part 5 shall be in conformity with the equal employment opportunity requirements of Executive Order 11246, as amended, and 29 CFR Part 30.

**5. Compliance with Copeland Act requirements.** The contractor shall comply with the requirements of 29 CFR Part 3 which are incorporated by reference in this contract

**6. Subcontracts.** The contractor or subcontractor will insert in any subcontracts the clauses contained in subparagraphs 1 through 11 in this paragraph A and such other clauses as HUD or its designee may by appropriate instructions require, and a copy of the applicable prevailing wage decision, and also a clause requiring the subcontractors to include these clauses in any lower tier subcontracts. The prime contractor shall be responsible for the compliance by any subcontractor or lower tier subcontractor with all the contract clauses in this paragraph.

**7. Contract termination; debarment.** A breach of the contract clauses in 29 CFR 5.5 may be grounds for termination of the contract and for debarment as a contractor and a subcontractor as provided in 29 CFR 5.12.

**8. Compliance with Davis-Bacon and Related Act Requirements.** All rulings and interpretations of the Davis-Bacon and Related Acts contained in 29 CFR Parts 1, 3, and 5 are herein incorporated by reference in this contract

**9. Disputes concerning labor standards.** Disputes arising out of the labor standards provisions of this contract shall not be subject to the general disputes clause of this contract. Such disputes shall be resolved in accordance with the procedures of the Department of Labor set forth in 29 CFR Parts 5, 6, and 7. Disputes within the meaning of this clause include disputes between the contractor (or any of its subcontractors) and HUD or its designee, the U.S. Department of Labor, or the employees or their representatives.

**10. (i) Certification of Eligibility.** By entering into this contract the contractor certifies that neither it (nor he or she) nor any person or firm who has an interest in the contractor's firm is a person or firm ineligible to be awarded Government contracts by virtue of Section 3(a) of the Davis-Bacon Act or 29 CFR 5.12(a)(1) or to be awarded HUD contracts or participate in HUD programs pursuant to 24 CFR Part 24.

(ii) No part of this contract shall be subcontracted to any person or firm ineligible for award of a Government contract by virtue of Section 3(a) of the Davis-Bacon Act or 29 CFR 5.12(a)(1) or to be awarded HUD contracts or participate in HUD programs pursuant to 24 CFR Part 24.

(iii) The penalty for making false statements is prescribed in the U.S. Criminal Code, 18 U.S.C. 1001. Additionally, U.S. Criminal Code, Section 1010, Title 18, U.S.C., "Federal Housing Administration transactions", provides in part: "Whoever, for the purpose of . . . influencing in any way the action of such Administration..... makes, utters or publishes any statement knowing the same to be false..... shall be fined not more than \$5,000 or imprisoned not more than two years, or both."

**11. Complaints, Proceedings, or Testimony by Employees.** No laborer or mechanic to whom the wage, salary, or other labor standards provisions of this Contract are applicable shall be discharged or in any other manner discriminated against by the Contractor or any subcontractor because such employee has filed any complaint or instituted or caused to be instituted any proceeding or has testified or is about to testify in any proceeding under or relating to the labor standards applicable under this Contract to his employer.

**B. Contract Work Hours and Safety Standards Act.** The provisions of this paragraph B are applicable where the amount of the prime contract exceeds \$100,000. As used in this paragraph, the terms "laborers" and "mechanics" include watchmen and guards.

**(1) Overtime requirements.** No contractor or subcontractor contracting for any part of the contract work which may require or involve the employment of laborers or mechanics shall require or permit any such laborer or mechanic in any workweek in which the individual is employed on such work to work in excess of 40 hours in such workweek unless such laborer or mechanic receives compensation at a rate not less than one and one-half times the basic rate of pay for all hours worked in excess of 40 hours in such workweek.

**(2) Violation; liability for unpaid wages; liquidated damages.** In the event of any violation of the clause set forth in subparagraph (1) of this paragraph, the contractor and any subcontractor responsible therefor shall be liable for the unpaid wages. In addition, such contractor and subcontractor shall be liable to the United States (in the case of work done under contract for the District of Columbia or a territory, to such District or to such territory), for liquidated damages. Such liquidated damages shall be computed with respect to each individual laborer or mechanic, including watchmen and guards, employed in violation of the clause set forth in subparagraph (1) of this paragraph, in the sum of \$10 for each calendar day on which such individual was required or permitted to work in excess of the standard workweek of 40 hours without payment of the overtime wages required by the clause set forth in subparagraph (1) of this paragraph.

**(3) Withholding for unpaid wages and liquidated damages.** HUD or its designee shall upon its own action or upon written request of an authorized representative of the Department of Labor withhold or cause to be withheld, from any moneys payable on account of work performed by the contractor or subcontractor under any such contract or any other Federal contract with the same prime contract, or any other Federally-assisted contract subject to the Contract Work Hours and Safety Standards Act which is held by the same prime contractor such sums as may be determined to be necessary to satisfy any liabilities of such contractor or subcontractor for unpaid wages and liquidated damages as provided in the clause set forth in subparagraph (2) of this paragraph.

**(4) Subcontracts.** The contractor or subcontractor shall insert in any subcontracts the clauses set forth in subparagraph (1) through (4) of this paragraph and also a clause requiring the subcontractors to include these clauses in any lower tier subcontracts. The prime contractor shall be responsible for compliance by any subcontractor or lower tier subcontractor with the clauses set forth in subparagraphs (1) through (4) of this paragraph.

**C. Health and Safety.** The provisions of this paragraph C are applicable where the amount of the prime contract exceeds \$100,000.

(1) No laborer or mechanic shall be required to work in surroundings or under working conditions which are unsanitary, hazardous, or dangerous to his health and safety as determined under construction safety and health standards promulgated by the Secretary of Labor by regulation.

(2) The Contractor shall comply with all regulations issued by the Secretary of Labor pursuant to Title 29 Part 1926 and failure to comply may result in imposition of sanctions pursuant to the Contract Work Hours and Safety Standards Act, (Public Law 91-54, 83 Stat 96). 40 USC 3701 et seq.

(3) The contractor shall include the provisions of this paragraph in every subcontract so that such provisions will be binding on each subcontractor. The contractor shall take such action with respect to any subcontractor as the Secretary of Housing and Urban Development or the Secretary of Labor shall direct as a means of enforcing such provisions

**U.S. Department of Housing and Urban Development  
Office of Labor Relations  
Form HUD-4010 (06/2009)  
ref. Handbook 1344.1**

## Appendix V – Sample Project Sign

Contractor shall furnish and erect a sign at the project site. The sign shall be made of 3/4-inch plywood, substantially in accordance with the drawings on next page. Sign shall be placed in a prominent location and maintained in good condition until completion of the project.

**Sign Dimensions: 1200mm x 2400mm x 19 mm (app. 4' x 8' x 3/4") Plywood Panel (APA Rated A-B grade – Exterior)**

**Colors: Background – Egg Shell (Off-White) Boarder and Lettering - Navy**

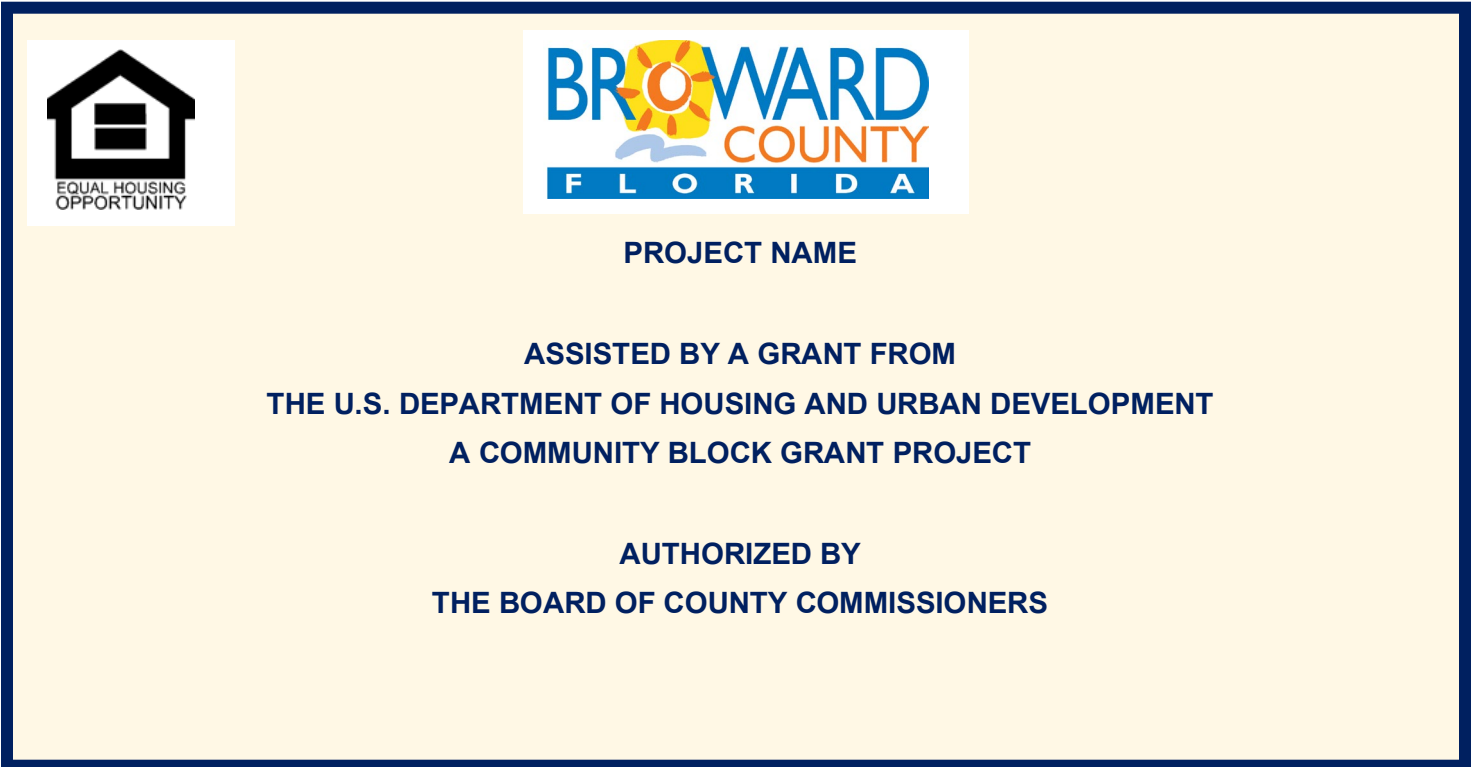

"General Decision Number: FL20240160 01/05/2024

Superseded General Decision Number: FL20230160

State: Florida

Construction Type: Highway

County: Broward County in Florida.

HIGHWAY CONSTRUCTION PROJECTS

Note: Contracts subject to the Davis-Bacon Act are generally required to pay at least the applicable minimum wage rate required under Executive Order 14026 or Executive Order 13658. Please note that these Executive Orders apply to covered contracts entered into by the federal government that are subject to the Davis-Bacon Act itself, but do not apply to contracts subject only to the Davis-Bacon Related Acts, including those set forth at 29 CFR 5.1(a)(1).

<p>If the contract is entered into on or after January 30, 2022, or the contract is renewed or extended (e.g., an option is exercised) on or after January 30, 2022:</p>	<p>. Executive Order 14026 generally applies to the contract.                  . The contractor must pay all covered workers at least \$17.20 per hour (or the applicable wage rate listed on this wage determination, if it is higher) for all hours spent performing on the contract in 2024.</p>
<p>If the contract was awarded on or between January 1, 2015 and January 29, 2022, and the contract is not renewed or extended on or after January 30, 2022:</p>	<p>. Executive Order 13658 generally applies to the contract.                  . The contractor must pay all covered workers at least \$12.90 per hour (or the applicable wage rate listed on this wage determination, if it is higher) for all hours spent performing on that contract in 2024.</p>

The applicable Executive Order minimum wage rate will be adjusted annually. If this contract is covered by one of the Executive Orders and a classification considered necessary for performance of work on the contract does not appear on this wage determination, the contractor must still submit a conformance request.

Additional information on contractor requirements and worker protections under the Executive Orders is available at <http://www.dol.gov/whd/govcontracts>.

Modification Number: 0  
 Publication Date: 01/05/2024

SUFL2013-021 08/19/2013

	Rates	Fringes	
CARPENTER.....	\$ 16.05 **	0.00	\$17.20
CEMENT MASON/CONCRETE FINISHER, Includes Form Work....	\$ 15.31 **	0.00	\$17.20
ELECTRICIAN.....	\$ 22.15	0.00	\$22.15
FENCE ERECTOR.....	\$ 12.82 **	0.00	\$17.20
HIGHWAY/PARKING LOT STRIPING: Operator (Striping Machine)....	\$ 15.75 **	0.00	\$17.20
HIGHWAY/PARKING LOT STRIPING: Painter.....	\$ 12.13 **	0.00	\$17.20
HIGHWAY/PARKING LOT STRIPING: Operator (Spray Nozzlemán).....	\$ 11.94 **	0.00	\$17.20
INSTALLER - GUARDRAIL.....	\$ 12.37 **	0.00	\$17.20

IRONWORKER, ORNAMENTAL.....	\$ 13.48 **	0.00	\$17.20
IRONWORKER, REINFORCING.....	\$ 16.84 **	0.00	\$17.20
IRONWORKER, STRUCTURAL.....	\$ 16.42 **	0.00	\$17.20
LABORER (Traffic Control Specialist incl. placing of cones/barricades/barrels - Setter, Mover, Sweeper).....	\$ 11.57 **	0.00	\$17.20
LABORER: Asphalt, Includes Raker, Shoveler, Spreader and Distributor.....	\$ 11.84 **	0.00	\$17.20
LABORER: Common or General.....	\$ 10.76 **	0.00	\$17.20
LABORER: Flagger.....	\$ 12.53 **	0.00	\$17.20
LABORER: Grade Checker.....	\$ 12.41 **	0.00	\$17.20
LABORER: Landscape & Irrigation.....	\$ 9.12 **	0.00	\$17.20
LABORER: Mason Tender - Cement/Concrete.....	\$ 13.91 **	3.50	\$17.20
LABORER: Pipelayer.....	\$ 14.61 **	0.00	\$17.20
OPERATOR: Backhoe/Excavator/Trackhoe.....	\$ 15.43 **	0.00	\$17.20
OPERATOR: Bobcat/Skid Steer/Skid Loader.....	\$ 12.88 **	0.00	\$17.20
OPERATOR: Boom.....	\$ 18.50	0.00	<del>\$17.20</del> \$18.50
OPERATOR: Boring Machine.....	\$ 17.33	0.00	\$17.33
OPERATOR: Broom/Sweeper.....	\$ 13.41 **	0.00	\$17.20
OPERATOR: Bulldozer.....	\$ 17.07 **	0.00	\$17.20
OPERATOR: Concrete Finishing Machine.....	\$ 15.44 **	0.00	\$17.20
OPERATOR: Concrete Saw.....	\$ 13.76 **	0.00	\$17.20
OPERATOR: Crane.....	\$ 19.14	0.00	\$19.14
OPERATOR: Curb Machine.....	\$ 21.33	0.00	\$21.33
OPERATOR: Distributor.....	\$ 13.13 **	0.00	\$17.20
OPERATOR: Drill.....	\$ 14.78 **	0.00	\$17.20
OPERATOR: Forklift.....	\$ 16.32 **	0.00	\$17.20
OPERATOR: Gradall.....	\$ 14.71 **	0.00	\$17.20
OPERATOR: Grader/Blade.....	\$ 18.98	0.00	\$18.98
OPERATOR: Loader.....	\$ 13.84 **	0.00	\$17.20
OPERATOR: Mechanic.....	\$ 18.03	0.00	\$18.03
OPERATOR: Milling Machine.....	\$ 14.89 **	0.00	\$17.20
OPERATOR: Oiler.....	\$ 16.32 **	0.00	\$17.20
OPERATOR: Paver (Asphalt, Aggregate, and Concrete).....	\$ 14.34 **	0.00	\$17.20
OPERATOR: Piledriver.....	\$ 17.23	0.00	\$17.23
OPERATOR: Post Driver (Guardrail/Fences).....	\$ 13.71 **	0.00	\$17.20
OPERATOR: Roller.....	\$ 13.10 **	0.00	\$17.20
OPERATOR: Scraper.....	\$ 12.01 **	0.00	\$17.20
OPERATOR: Screed.....	\$ 14.85 **	0.00	\$17.20
OPERATOR: Tractor.....	\$ 12.62 **	0.00	\$17.20

OPERATOR: Trencher.....\$ 14.58 **	0.00	\$ 17.20
PAINTER: Spray.....\$ 16.52 **	0.00	\$ 17.20
SIGN ERECTOR.....\$ 14.23 **	0.00	\$ 17.20
TRAFFIC SIGNALIZATION: Traffic Signal Installation.....\$ 14.74 **	0.00	\$ 17.20
TRUCK DRIVER: Distributor Truck.....\$ 14.96 **	2.17	\$ 17.20 + 2.17
TRUCK DRIVER: Dump Truck.....\$ 11.71 **	0.00	\$ 17.20
TRUCK DRIVER: Flatbed Truck.....\$ 14.28 **	0.00	\$ 17.20
TRUCK DRIVER: Lowboy Truck.....\$ 14.06 **	0.00	\$ 17.20
TRUCK DRIVER: Slurry Truck.....\$ 11.96 **	0.00	\$ 17.20
TRUCK DRIVER: Vactor Truck.....\$ 14.21 **	0.00	\$ 17.20
TRUCK DRIVER: Water Truck.....\$ 13.22 **	0.00	\$ 17.20

\$ 19.37

WELDERS - Receive rate prescribed for craft performing operation to which welding is incidental.

\*\*\*\*\*  
 \*\* Workers in this classification may be entitled to a higher minimum wage under Executive Order 14026 (\$17.20) or 13658 (\$12.90). Please see the Note at the top of the wage determination for more information. Please also note that the minimum wage requirements of Executive Order 14026 are not currently being enforced as to any contract or subcontract to which the states of Texas, Louisiana, or Mississippi, including their agencies, are a party.

Note: Executive Order (EO) 13706, Establishing Paid Sick Leave for Federal Contractors applies to all contracts subject to the Davis-Bacon Act for which the contract is awarded (and any solicitation was issued) on or after January 1, 2017. If this contract is covered by the EO, the contractor must provide employees with 1 hour of paid sick leave for every 30 hours they work, up to 56 hours of paid sick leave each year. Employees must be permitted to use paid sick leave for their own illness, injury or other health-related needs, including preventive care; to assist a family member (or person who is like family to the employee) who is ill, injured, or has other health-related needs, including preventive care; or for reasons resulting from, or to assist a family member (or person who is like family to the employee) who is a victim of, domestic violence, sexual assault, or stalking. Additional information on contractor requirements and worker protections under the EO is available at <https://www.dol.gov/agencies/whd/government-contracts>.

Unlisted classifications needed for work not included within the scope of the classifications listed may be added after award only as provided in the labor standards contract clauses (29CFR 5.5 (a) (1) (iii)).

-----  
 The body of each wage determination lists the classification and wage rates that have been found to be prevailing for the cited type(s) of construction in the area covered by the wage determination. The classifications are listed in alphabetical order of "identifiers" that indicate whether the particular rate is a union rate (current union negotiated rate for local), a survey rate (weighted average rate) or a union average rate (weighted union average rate).

Union Rate Identifiers

A four letter classification abbreviation identifier enclosed in dotted lines beginning with characters other than "SU" or "UAVG" denotes that the union classification and rate were prevailing for that classification in the survey. Example: PLUM0198-005 07/01/2014. PLUM is an abbreviation identifier of the union which prevailed in the survey for this classification, which in this example would be Plumbers. 0198 indicates the local union number or district council number where applicable, i.e., Plumbers Local 0198. The next number,

005 in the example, is an internal number used in processing the wage determination. 07/01/2014 is the effective date of the most current negotiated rate, which in this example is July 1, 2014.

Union prevailing wage rates are updated to reflect all rate changes in the collective bargaining agreement (CBA) governing this classification and rate.

#### Survey Rate Identifiers

Classifications listed under the "SU" identifier indicate that no one rate prevailed for this classification in the survey and the published rate is derived by computing a weighted average rate based on all the rates reported in the survey for that classification. As this weighted average rate includes all rates reported in the survey, it may include both union and non-union rates. Example: SULA2012-007 5/13/2014. SU indicates the rates are survey rates based on a weighted average calculation of rates and are not majority rates. LA indicates the State of Louisiana. 2012 is the year of survey on which these classifications and rates are based. The next number, 007 in the example, is an internal number used in producing the wage determination. 5/13/2014 indicates the survey completion date for the classifications and rates under that identifier.

Survey wage rates are not updated and remain in effect until a new survey is conducted.

#### Union Average Rate Identifiers

Classification(s) listed under the UAVG identifier indicate that no single majority rate prevailed for those classifications; however, 100% of the data reported for the classifications was union data. EXAMPLE: UAVG-OH-0010 08/29/2014. UAVG indicates that the rate is a weighted union average rate. OH indicates the state. The next number, 0010 in the example, is an internal number used in producing the wage determination. 08/29/2014 indicates the survey completion date for the classifications and rates under that identifier.

A UAVG rate will be updated once a year, usually in January of each year, to reflect a weighted average of the current negotiated/CBA rate of the union locals from which the rate is based.

---

#### WAGE DETERMINATION APPEALS PROCESS

1.) Has there been an initial decision in the matter? This can be:

- \* an existing published wage determination
- \* a survey underlying a wage determination
- \* a Wage and Hour Division letter setting forth a position on a wage determination matter
- \* a conformance (additional classification and rate) ruling

On survey related matters, initial contact, including requests for summaries of surveys, should be with the Wage and Hour National Office because National Office has responsibility for the Davis-Bacon survey program. If the response from this initial contact is not satisfactory, then the process described in 2.) and 3.) should be followed.

With regard to any other matter not yet ripe for the formal process described here, initial contact should be with the Branch of Construction Wage Determinations. Write to:

Branch of Construction Wage Determinations  
Wage and Hour Division  
U.S. Department of Labor  
200 Constitution Avenue, N.W.  
Washington, DC 20210

2.) If the answer to the question in 1.) is yes, then an interested party (those affected by the action) can request review and reconsideration from the Wage and Hour Administrator (See 29 CFR Part 1.8 and 29 CFR Part 7). Write to:

Wage and Hour Administrator  
U.S. Department of Labor  
200 Constitution Avenue, N.W.  
Washington, DC 20210

The request should be accompanied by a full statement of the interested party's position and by any information (wage payment data, project description, area practice material, etc.) that the requestor considers relevant to the issue.

3.) If the decision of the Administrator is not favorable, an interested party may appeal directly to the Administrative Review Board (formerly the Wage Appeals Board). Write to:

Administrative Review Board  
U.S. Department of Labor  
200 Constitution Avenue, N.W.  
Washington, DC 20210

4.) All decisions by the Administrative Review Board are final.

=====

END OF GENERAL DECISION"

SECTION 00300

PROPOSAL

**(BID FORM)**

Submitted: \_\_\_\_\_, 20\_\_\_\_.

City Clerk's Office City Hall  
1965 South State Road 7  
West Park, FL 33023

Bidders:

The undersigned, as Bidder, hereby declares that the only person or persons interested in the Proposal, as principal or principals, is or are named herein and that no other person than herein mentioned has any interest in the Proposal of the Contract to which the work pertains; that this Proposal is made without connection or arrangement with any other person, company, or parties making a bid or proposal and that the Proposal is in all respects fair and made in good faith without collusion or fraud.

The Bidder further declares that he has examined the site of the work and that from personal knowledge and experience, or that he has made sufficient observations of the conditions of the project site to satisfy himself that such site is a correct and suitable one for this work and he assumes full responsibility therefore, that he has examined the Drawings and Specifications for the work and from his own experience or from professional advice that the Drawings and Specifications are sufficient for the work to be done and he has examined the other Contractual Documents relating thereto, including the Notice of Bid Invitation, Instructions to Bidders, Proposal, Contract, General and Special Conditions, Technical Specifications, Drawings and has read all addenda prior to the receipt of bids, and that he has satisfied himself fully, relative to all matters and conditions with respect to the work to which this Proposal pertains.

The Bidder further proposes and agrees, if this Proposal is accepted, to contract with the City of West Park (Owner), in the form of contract specified, to furnish all necessary materials, all equipment, all necessary machinery, tools, apparatus, means of transportation, and labor necessary to complete the work specified in the Proposal and the Contract, and called for by the Drawings and Specifications and in the manner specified. The Bidder further proposes and agrees to comply in all respects with the time limits for commencement and completion of the work as stated in the Contract Form.

The Bidder further agrees that the deductions for liquidated damages, as stated in the Contract Form, constitute fixed, agreed, and liquidated damages to reimburse the Owner for additional costs to the Owner resulting from the work not being completed within the time limit stated in the Contract Form.

The Bidder further agrees to execute a Contract and furnish satisfactory Performance and Payment Bonds each in the amount of one-hundred percent (110%) of the Contract price, within ten (10) consecutive calendar days after written notice being given by the Owner of the award of the Contract, and the undersigned agrees that in case of failure on his part to execute the said Contract and Performance and Payment Bonds within the ten (10) consecutive calendar days after the award of the Contract, the cashier's check or Bid Bond accompanying his bid and the money payable thereon shall be paid to the Owner as liquidation of damages sustained by the Owner; otherwise, the check accompanying the Proposal shall be returned to the undersigned after the Contract is signed and the Performance and Payment Bonds are filed.

NOTICE TO ALL BIDDERS

The undersigned agrees to accept in full compensation therefore the total of the lump sum prices for the items named in the following schedule, based on the quantities actually constructed as determined by the applicable measurement and payment portion of the technical specifications.

Bidders Certificate of Competency No. \_\_\_\_\_

Bidders Occupational License No. \_\_\_\_\_

Acknowledgment is hereby made of the following Addenda received since issuance of the Project

Manual: Addendum No. \_\_\_\_\_ Dated: \_\_\_\_\_ Addendum No. \_\_\_\_\_ Dated: \_\_\_\_\_

Addendum No. \_\_\_\_\_ Dated: \_\_\_\_\_ Addendum No. \_\_\_\_\_ Dated: \_\_\_\_\_ Addendum No.

\_\_\_\_\_ Dated: \_\_\_\_\_ Addendum No. \_\_\_\_\_ Dated: \_\_\_\_\_

Attached hereto is a cashier's check on the \_\_\_\_\_

\_\_\_\_\_ Bank of \_\_\_\_\_ Dollars

(\$ \_\_\_\_\_), made payable to the City West Park, Florida.

\_\_\_\_\_ L.S. (Name of Bidder) (Affix Seal)

\_\_\_\_\_ L.S. Signature of Officer

\_\_\_\_\_ L.S. (Title of Officer)

Address: \_\_\_\_\_

City: \_\_\_\_\_ State: \_\_\_\_\_

The full names and residences of persons and firms interested in the foregoing bid, as principals, are as follows:

Name of the executive who will give personal attention to the work: \_\_\_\_\_

Attach list of subcontractors

\_\_\_\_\_  
\_\_\_\_\_  
\_\_\_\_\_

1-The City of West Park reserves the right to waive any information in any bid, to reject any and all bids and to delete any part of the above items.

2-Changes in the Contract Price and Contract Time require prior authorization in writing from Owner and the Engineer, in the form of a Change Order or Work Change Directive. The Contractor is responsible for verification of all bid quantities and to report to the Engineer any discrepancies found prior to ordering materials and or equipment for construction. Refer to General Conditions.

3-Bid prices for the various divisions and work items are intended to establish a total price for completing the project in its entirety. The Contractor shall include in the Bid, any item for which a separate division has not been established in the Base Bid Form (under any related division), to reflect the total price for completing the project in its entirety, as specified in the Project Manual and Construction Drawings.

4-Contractor is responsible for restoring all areas disturbed during construction, including swale, sidewalk, and landscaped areas. Swale must be restored with St. Augustine grass unless otherwise instructed. Field restoration shall be as specified or as otherwise directed by Engineer. Cost of restoration and watering of areas disturbed during construction must be included as part of the entire bid.

---

**Name of Bidder**

---

**Signature of Bidder**

**Bid Form Project Name: CITYWIDE SIDEWALK RESTORATION AND ADA COMPLAINTCE – PHASE 2**

**City's Project No.: \_\_\_\_\_ IFB No. 24-0409**

**BID FORM**

Bid prices stated in the proposal include all costs and expenses for mobilization, taxes, labor, equipment, materials, contractors' overhead and profit. The quantities for payment under this Contract will be determined by completed items in place, ready for service and accepted by the Owner. Contract prices are intended to establish a total price for completing the project in its entirety. All work not listed in the Bid Form but required in order to furnish and install all elements as intended, shall be included in the proposal. All work, mobilization, funding agency compliance requirements, general and supplementary conditions, quality control requirements, utility coordination, dust control, Florida Trench Safety Act, Pollution prevention and incidental costs shall be included in the overall contract, no separate payment or additional payment will be made.

<u>Item No./ Description</u>	<u>Qty.</u>	<u>Unit</u>	<u>Unit Price</u>	<u>Total Price</u>
1.0 Clearing & Grubbing (Includes removal & disposal of misc. asphalt, rocks, sod, dirt, tree roots, vegetation)	0.05	AC.	\$ _____	\$ _____
2.0 Maintenance of Traffic (MOT) (Includes maintenance of pedestrian traffic)	1	L.S.	\$ _____	\$ _____
3.0 Removal & Disposal of Concrete Sidewalk, Ramps, curb, Aprons (6" avg. thickness) (Incl. Sawcutting & Dust Control)	700	S.Y.	\$ _____	\$ _____
4.0 Concrete Sidewalk & Ramps (6" )(ADA) (Includes excavating, compacting, and adjacent inlet apron adjustment where applicable)	750	S.Y.	\$ _____	\$ _____
5.0 Concrete Curb & Gutter/Drop Curb (As directed by city)	100	L.F.	\$ _____	\$ _____
6.0 Detectable Warning Surface (Cast-in-place / Wet-Set)	1,200	S.F.	\$ _____	\$ _____
7.0 Retro Reflective Pavement Markers	450	EA	\$ _____	\$ _____
8.0 Thermoplastic White (Solid)(24")	1,350	L.F.	\$ _____	\$ _____
9.0 Thermoplastic Yellow (Solid)(6")	2.1	G.M.	\$ _____	\$ _____
10.0 Project Signage (Furnish/Install)	1	EA	\$ _____	\$ _____
11.0 Performance & Payment Bond	1	L.S.	\$ _____	\$ _____
12.0 Off-Duty Police Officer (Allowance)	80	HRS	\$ <u>45</u>	\$ <u>3,600.00</u>
13.0 Owners Contingency (Do Not Bid)			\$ <u>5,000.00</u>	\$ <u>5,000.00</u>

**TOTAL BID PRICE** \$ \_\_\_\_\_

**BID AMOUNT (IN WORDS)**

---



---

**BIDDER (Company Name):**

---

---

**NAME OF REPRESENTATIVE (PRINT)** \_\_\_\_\_

---

**TITLE:** \_\_\_\_\_

**BIDDER'S CONTACT INFO.**

**PHONE NO.:** \_\_\_\_\_

**PHONE NO.:** \_\_\_\_\_

**EMAIL :** \_\_\_\_\_

**NOTES:**

---

---

---

---



**END OF SECTION**

## LIST OF MAJOR SUB CONTRACTOR

Bidders are required to list with the Proposal, on this attached sheet all major sub-contractors included for the prosecution of the work. Failure to complete the list may be cause for declaring the Proposal irregular.

The successful bidder shall employ the sub-contractors listed hereunder for the class of work indicated, which list shall not be modified in any way without the written consent of the City of West Park.

The Bidder expressly agrees that:

If awarded a contract as a result of this proposal, the major sub-contractors used in the prosecution of the work will be those listed below.

The Bidder represents that the sub-contractors listed below are financially responsible and are qualified to do the work required.

All pavement marking and signing sub-contractors shall have an active Broward County Certificate of Competency if applicable.

**CATEGORY OR CLASS NAME OF SUB-CONTRACTOR ADDRESS OF WORK**

**END OF SECTION**

SECTION 00350

CONTINUED QUESTIONARE

Submitted to: The Mayor and City Commission of the City of West Park, Florida:

By \_\_\_\_\_

Principal Office \_\_\_\_\_

How many years has your organization been in business as a General Contractor under your present business name? \_\_\_\_\_

Does your organization have current occupational licenses entitling it to do the work contemplated in this Contract? \_\_\_\_\_

State of Florida License: (State type and number):

\_\_\_\_\_

Federal I.D. No: \_\_\_\_\_

Broward County Certificate of Competency: (State type and number):

\_\_\_\_\_

~~City of West Park Contractor Registration: (State type and number): n/a (Pre registration not required)~~

\_\_\_\_\_

Include copies of above licenses and certifications with proposal: \_\_\_\_\_

How many years experience in similar work has your organization had?

- (A) As a General Contractor \_\_\_\_\_
- (B) As a Sub-Contractor \_\_\_\_\_
- (C) What contracts has your organization completed within the last five (5) years? State below:

<b>Contract Amount</b>	<b>Class of Work</b>	<b>when completed</b>	<b>Name &amp; Address of Owner</b>
_____	_____	_____	_____
_____	_____	_____	_____
_____	_____	_____	_____
_____	_____	_____	_____

Are you a Certified Minority Contractor with Broward County?

\_\_\_\_\_

Have you ever failed to complete any work awarded to you? \_\_\_\_\_

If so, where and why? \_\_\_\_\_

\_\_\_\_\_

Has any officer or partner of your organization ever failed to complete a contract handled in his own name? \_\_\_\_\_

If so, state name of individual, name of owner, and reason thereof:

\_\_\_\_\_

\_\_\_\_\_

In what other lines of business are you financially interested or engaged?

\_\_\_\_\_

\_\_\_\_\_

\_\_\_\_\_

Give references as to experience, ability and financial standing:

\_\_\_\_\_

\_\_\_\_\_

\_\_\_\_\_

What equipment do you own that is available for the proposed work and where is it located?

\_\_\_\_\_

\_\_\_\_\_

\_\_\_\_\_

Financial Statement: \_\_\_\_\_

\_\_\_\_\_

\_\_\_\_\_

**END OF SECTION**

SECTION 00410

BID BOND

STATE OF FLORIDA )  
 : ss  
COUNTY OF BROWARD )

**KNOW ALL MEN BY THESE PRESENTS**, that \_\_\_\_\_ as Principal, and \_\_\_\_\_, as Surety, a Corporation chartered and existing under the laws of the State of \_\_\_\_\_, with its principal offices in the City of \_\_\_\_\_, and authorized to do business in the State of Florida are held and firmly bound unto the Owner, \_\_\_\_\_ in the penal sum of \_\_\_\_\_ Dollars (\$ \_\_\_\_\_) or 5% of bid amount lawful money of the United States, for the payment of which sum will and truly to be made, we bind ourselves, our heirs, executors, administrators, and successors, jointly and severally, firmly by these presents.

**THE CONDITION OF THIS OBLIGATION IS SUCH**, that whereas the Principal has submitted the accompanying bid, dated \_\_\_\_\_, 20\_\_\_\_, for:

**Project Description** \_\_\_\_\_

**Project No:** \_\_\_\_\_

**NOW, THEREFORE:**

- A. If the principal shall not withdraw said bid within sixty (60) days after date of opening of the same, and shall within ten (10) days after the prescribed forms are presented to him for signature, enter into a written contract with the Owner in accordance with the bid as accepted, and give bonds with good and sufficient surety or sureties, as may be required, for the faithful performance and proper fulfillment of such contract, then the above obligations shall be void and of no effect, otherwise to remain in full force and effect.
- B. In the event of the withdrawal of said bid within the period specified, or the failure to enter into such contract and give such bonds within the time specified, if the principal shall pay the Owner the difference between the amount specified in said bid and the amount for which the Owner may procure the required work and supplies, if the latter amount be in excess of the former, then the above obligations shall be void and of no effect, otherwise to remain in full force and effect.

**IN WITNESS WHEREOF**, the above bounded parties have executed this instrument under their several seals, this day of \_\_\_\_\_, A.D., 20\_\_\_\_, the name and corporate seal of each corporate party being hereto affixed and these presents duly signed by its undersigned representative, pursuant to authority of its governing body.

WITNESSES: (If Sole Ownership or Partnership, two (2) witnesses required).  
(If Corporation, Secretary Only will attest and affix seal).

**WITNESSES:**

\_\_\_\_\_  
\_\_\_\_\_

**PRINCIPAL:**

\_\_\_\_\_  
Name of Firm

\_\_\_\_\_  
Signature of Authorized (Affix Seal)

\_\_\_\_\_  
Title

\_\_\_\_\_  
Business Address

\_\_\_\_\_  
City, State & Zip Code

**SURETY:**

\_\_\_\_\_  
Corporate Surety

\_\_\_\_\_  
Attorney-in-Fact (Affix Seal)

\_\_\_\_\_  
Business Address

\_\_\_\_\_  
City, State & Zip Code

\_\_\_\_\_  
Name of Local Insurance Agency

**END OF SECTION**

SECTION 00500

CONTRACT AGREEMENT

CONTRACT AGREEMENT

THIS IS AN AGREEMENT, dated the \_\_\_ day of \_\_\_\_\_, 2024,  
between:

CITY OF WEST PARK  
a Florida municipal corporation, hereinafter "CITY,"

and

\_\_\_\_\_ a for profit corporation, authorized to do business in the  
State of Florida, hereinafter "CONTRACTOR."

WITNESSETH:

In consideration of the mutual terms and condition, promises, covenants, and payments hereinafter set forth, CITY and CONTRACTOR agree as follows:

ARTICLE 1  
PREAMBLE

In order to establish the background, context and form of reference for this Agreement and to generally express the objectives, and intentions, of the respective parties herein, the following statements, representations and explanations shall be accepted as predicates for the undertakings and commitments included within the provisions which follow and may be relied upon by the parties as essential elements of the mutual considerations upon which this Agreement is based.

1.1 CITY is in need of an independent contractor to perform work related to site improvements for the Citywide Sidewalk Restoration and ADA Compliance - Phase 2 project within the City of West Park.

1.2 CITY requested sealed bids from qualified licensed contractors for Citywide Sidewalk Restoration and ADA Compliance - Phase 2 project through ITB No: 24-0409; and

ARTICLE 2  
SCOPE OF WORK

2.1 The CONTRACTOR shall furnish all of the materials, tools, supplies, and labor necessary to perform all of the work described in the Invitation for Bid - ITB No: 24-0409 - Citywide Sidewalk Restoration and ADA Compliance - Phase 2, a copy of

which is attached hereto and specifically made a part of this Agreement as Exhibit "A" and in the Bid Response ("Bid") from CONTRACTOR, dated \_\_\_\_\_, 2024, a copy of which is attached hereto and specifically made a part of this Agreement as Exhibit "B".

2.2 CONTRACTOR hereby represents to CITY, with full knowledge that CITY is relying upon these representations when entering into this Agreement with CONTRACTOR, that CONTRACTOR has the professional expertise, experience and manpower to perform the services to be provided by CONTRACTOR pursuant to the terms of this Agreement.

2.3 CONTRACTOR assumes professional and technical responsibility for performance of its services to be provided hereunder in accordance with applicable recognized professional standards. If within twelve (12) months following completion of its services, such services fail to meet the aforesaid standards, and the CITY promptly advises CONTRACTOR thereof in writing, CONTRACTOR agrees to re-perform such deficient services without charge to the CITY.

2.4 None of the work or services under this contract shall be subcontracted beyond that shown on List of Major Sub-Contractors submitted to the CITY by CONTRACTOR, unless CONTRACTOR obtains prior written consent from the CITY. Approved subcontractors shall be subject to each provision of this contract and CONTRACTOR shall be responsible and indemnify the CITY for all subcontractors' acts, errors or omissions.

### ARTICLE 3 TIME FOR COMPLETION AND LIQUIDATED DAMAGES

3.1 The CONTRACTOR shall commence work as directed by CITY and in accordance with a project timeline to be provided to CONTRACTOR by the CITY. CONTRACTOR shall complete all work in a timely manner, but no later than **90 calendar days from the date of NTP**, as directed by CITY and as stated in Exhibit "A" to this Agreement.

3.2 It is mutually agreed that time is of the essence of this Contract and should the CONTRACTOR fail to complete the work within the specified time, or any authorized extension thereof, there shall be deducted from the compensation otherwise to be paid to the CONTRACTOR, and the CITY will retain as liquidated damages the amount of **One Thousand Dollars (\$1,000.00) per calendar day** for each calendar day elapsing beyond the specified time for completion or any authorized extension thereof, which sum shall represent the actual damages which the CITY will have sustained by failure of the CONTRACTOR to complete the work within the specified time. It is further agreed that said sum is not penalty, but is the stipulated amount of damage sustained by the CITY in the event of such default by the CONTRACTOR.

3.3 Anything to the contrary notwithstanding, minor adjustment to the timetable for completion approved by CITY in advance, in writing, will not constitute a delay by CONTRACTOR. Furthermore, a delay due to an Act of God, fire, lockout, strike or labor dispute, riot or civil commotion, act of public enemy or other cause beyond the control of CONTRACTOR shall extend this Agreement for a period equal to such delay and during this period such delay shall not constitute a delay by CONTRACTOR for which liquidated damages are due.

#### ARTICLE 4 CONTRACT SUM

4.1 The CITY hereby agrees to pay CONTRACTOR for the faithful performance of this Agreement, for work completed in accordance with the Invitation for Bid - ITB No: 24-0409 - Citywide Sidewalk Restoration and ADA Compliance - Phase 2, dated 2024, attached hereto as Exhibit "A", and as directed by CITY. Prices for work completed by the CONTRACTOR shall be as reflected in CONTRACTOR's Bid Response to ITB No. 24-0409, a copy of which is attached hereto and made a part hereof as Exhibit "B". A total contact price hereto is referred to as Contract Sum and shall not exceed \_\_\_\_\_ Dollars (\$ \_\_\_\_).

4.2 The CITY will make payments to CONTRACTOR for completed and proper work and in for the amounts stated in Exhibits "A" and "B".

4.3 The CONTRACTOR shall guarantee all portions of the Project against poor workmanship and faulty materials for a period of twelve (12) months after final payment and shall immediately correct any defects, which may appear during this period upon notification by CITY.

4.4 The making and acceptance of the final payment shall constitute a waiver of all claims by the CONTRACTOR other than those arising from requirements of the specifications.

4.5 CONTRACTOR is prohibited from placing a lien on the City's property. This prohibition applies to; *inter alia*, all sub-consultants and subcontractors, suppliers and labors.

#### ARTICLE 5 CONTRACTOR'S LIABILITY INSURANCE

5.1 The CONTRACTOR shall not commence work under this contract until he has obtained all insurance required under this paragraph and such insurance has been approved by the CITY nor shall the CONTRACTOR allow any Subcontractor to commence work on his sub-contract until all similar such insurance required of the subcontractor has been obtained and approved.

5.2 Certificates of insurance, reflecting evidence of the required insurance, shall be filed with the City prior to the commencement of the work. These Certificates shall contain a provision that coverage afforded under these policies will not be canceled until at least thirty (30) days prior written notice has been given to the CITY. Policies shall be issued by companies authorized to do business under the laws of the State of Florida.

5.3 Financial Ratings must be no less than "A" in the latest edition of "Bests Key Rating Guide", published by A.M. Best Guide.

5.4 Insurance shall be in force until all work required to be performed under the terms of the Contract is satisfactorily completed as evidenced by the formal acceptance by the CITY. In the event the insurance certificate provided indicates that the insurance shall terminate and lapse during the period of this contract, then in that event, the CONTRACTOR shall furnish, at least thirty (30) days prior to the expiration of the date of such insurance, a renewed certificate of insurance as proof that equal and like coverage for the balance of the period of the contract and extension thereunder is in effect. The CONTRACTOR shall not continue to work pursuant to this contract unless all required insurance remains in full force and effect.

5.5 Comprehensive General Liability insurance to cover liability bodily injury and property damage. Exposures to be covered are premises, operations, products/completed operations, and certain contracts. Coverage must be written on an occurrence basis, with the following limits of liability:

- a) Workers' Compensation Insurance - as required by law;
- b) Employer's Liability Insurance - \$500,000 per occurrence;
- c) Automobile Liability Insurance - \$500,000 per occurrence, \$500,000 per Accident for bodily injury and \$500,000 per accident for property damage.

5.6 The CONTRACTOR shall hold the CITY, its agents, and employees, harmless on account of claims for damages to persons, property or premises arising out of the operations to complete this Agreement and name the CITY as an additional insured under their policy.

5.7 The CITY reserves the right to require any other insurance coverage it deems necessary depending upon the exposures.

## ARTICLE 6 PROTECTION OF PROPERTY

6.1 At all times during the performance of this Contract, the CONTRACTOR shall protect the CITY's property and properties adjoining the Project site from all damage whatsoever on account of the work being carried on pursuant to this Agreement.

ARTICLE 7  
CONTRACTOR'S INDEMNIFICATION

7.1 The CONTRACTOR agrees to release the CITY from and against any and all liability and responsibility in connection with the above-mentioned matters. The CONTRACTOR further agrees not to sue or seek any money or damages from CITY in connection with the above-mentioned matters.

7.2 The CONTRACTOR agrees to indemnify and hold harmless the CITY, its trustees, elected and appointed officers, agents, servants and employees, from and against any and all claims, demands, or causes of action of whatsoever kind or nature, and the resulting losses, costs, expenses, reasonable attorneys' fees, liabilities, damages, orders, judgments, or decrees, sustained by the CITY or any third party arising out of, or by reason of, or resulting from the CONTRACTOR's negligent acts, errors, or omissions.

7.3 If a court of competent jurisdiction holds the City liable for certain, tortuous acts of its agents, officers, or employees, such liability shall be limited to the extent and limit provided in 768.28, Florida Statutes. This provision shall not be construed as a waiver of any right or defense that the City may possess. The City specifically reserves all rights as against any and all claims that may be brought.

ARTICLE 8  
INDEPENDENT CONTRACTOR

8.1 This Agreement does not create an employee/employer relationship between the parties. It is the intent of the parties that the CONTRACTOR is an independent contractor under this Agreement and not the CITY's employee for all purposes, including but not limited to, the application of the Fair Labor Standards Act minimum wage and overtime payments, Federal Insurance Contribution Act, the Social Security Act, the Federal Unemployment Tax Act, the provisions of the Internal Revenue Code, the State Workers Compensation Act, and the State unemployment insurance law. The CONTRACTOR shall retain sole and absolute discretion in the judgment of the manner and means of carrying out the CONTRACTOR's activities and responsibilities hereunder provided. This Agreement shall not be construed as creating any joint employment relationship between the CONTRACTOR and the CITY and the CITY will not be liable for any obligation incurred by CONTRACTOR, including but not limited to unpaid minimum wages and/or overtime premiums.

ARTICLE 9  
PERFORMANCE BOND

9.1 A performance bond shall be required for this Agreement in the amount of 110% of the total construction cost.

ARTICLE 10  
CHANGES TO SCOPE OF WORK AND ADDITIONAL WORK

10.1 CITY or CONTRACTOR may request changes that would increase decrease or otherwise modify the Scope of Services/Basic Services to be provided under this Agreement as described in Article 2 of this Agreement. Such changes or additional services must be in accordance with the provisions of the Code of Ordinances of the CITY and must be contained in a written amendment, executed by the parties hereto, with the same formality and with equality and dignity prior to any deviation from the terms of this Agreement, including the initiation of any additional or extra work. Each amendment shall at a minimum include the following information on each project:

PROJECT NAME  
PROJECT DESCRIPTION  
ESTIMATED PROJECT COST  
ESTIMATED COST FOR ADDITION OR CHANGE TO PROJECT CONTRACT  
ESTIMATED PROJECT COMPLETION DATE

10.2 In no event will the CONTRACTOR be compensated for any work, which has not been described in a separate written agreement executed by the parties hereto.

ARTICLE 11  
TERM AND TERMINATION

11.1 This Agreement may be terminated by either party for cause, or the CITY for convenience, upon thirty (30) days written notice by the CITY to CONTRACTOR in which event the CONTRACTOR shall be paid its compensation for services performed to termination date. In the event that the CONTRACTOR abandons this Agreement or causes it to be terminated, he shall indemnify the CITY against any loss pertaining to this termination up to a maximum of the full contracted fee amount. All finished or unfinished documents, data, studies, plans, surveys, and reports prepared by CONTRACTOR shall become the property of CITY and shall be delivered by CONTRACTOR to CITY.

11.2 This Agreement shall take effect as of the date of execution as shown herein below and continue for such time as is contemplated by the CITY.

ARTICLE 12  
CONTRACT DOCUMENTS

12.1 CONTRACTOR and CITY hereby agree that the following Specification and Contract Documents, which are attached hereto and made a part thereof, are fully incorporated herein and made a part of this Agreement, as if written herein word for word: this Agreement; Invitation for Bid - ITB No: 24-0409 - Citywide Sidewalk Restoration and ADA Compliance - Phase 2, as set forth in and made a part of this Agreement as Exhibit "A"; CONTRACTOR's Bid in response to ITB No. 24-0409, as set forth and made a part of this Agreement as Exhibit "B"; and all other exhibits thereto.

ARTICLE 13  
MISCELLANEOUS

13.1 Legal Representation. It is acknowledged that each party to this Agreement had the opportunity to be represented by counsel in the preparation of this Agreement and, accordingly, the rule that a contract shall be interpreted strictly against the party preparing same shall not apply due to the joint contribution of both parties.

13.2 Assignments. This Agreement, or any interest herein, shall not be assigned, transferred or otherwise encumbered, under any circumstances, by CONTRACTOR without the prior written consent of CITY; provided however, that claims for money by the CONTRACTOR from the CITY under this contract may be assigned, transferred or pledged to a bank, trust company, or other financial institution without the CITY's approval. Written notice of any assignment, transfer or pledge of funds shall be furnished within ten (10) days by the CONTRACTOR to the CITY. For purposes of this Agreement, any change of ownership of CONTRACTOR shall constitute an assignment, which requires CITY approval. However, this Agreement shall run to the CITY and its successors and assigns.

13.3 Records. CONTRACTOR shall keep books and records and require any and all subcontractors to keep books and records as may be necessary in order to record complete and correct entries as to personnel hours charged to this engagement, and any expenses for which CONTRACTOR expects to be reimbursed, if applicable. Such books and records will be available at all reasonable times for examination and audit by CITY and shall be kept for a period of three (3) years after the completion of all work to be performed pursuant to this Agreement. Incomplete or incorrect entries in such books and records will be grounds for disallowance by CITY of any fees or expenses based upon such entries.

CITY is a public agency subject to Chapter 119, Florida Statutes. To the extent CONTRACTOR is acting on behalf of CITY pursuant to Section 119.0701, Florida Statutes, CONTRACTOR shall:

- a. Keep and maintain public records that ordinarily and necessarily would be required to be kept and maintained by CITY were CITY performing the services under this agreement;
- b. Provide the public with access to such public records on the same terms and conditions that the County would provide the records and at a cost that does not exceed that provided in Chapter 119, Florida Statutes, or as otherwise provided by law;
- c. Ensure that public records that are exempt or that are confidential and exempt from public record requirements are not disclosed except as authorized by law; and
- d. Meet all requirements for retaining public records and transfer to CITY, at no cost, all public records in possession of the CONTRACTOR upon termination of this Agreement and destroy any duplicate public records that are exempt or confidential and exempt. All records stored electronically must be provided to the CITY.
- e. IF THE CONTRACTOR HAS QUESTIONS REGARDING THE APPLICATION OF CHAPTER 119, FLORIDA STATUTES, TO THE CONTRACTOR'S DUTY TO PROVIDE PUBLIC RECORDS RELATING TO THIS CONTRACT, **CONTACT THE CUSTODIAN OF PUBLIC RECORDS AT: (954) 989-2688 ext. 205; agrant@cityofwestpark.org; 1965 South State Road 7, West Park, FL 33023.**

13.4 Ownership of Documents. Reports, surveys, plans, studies and other data provided in connection with this Agreement are and shall remain the property of City.

13.5 No Contingent Fees. CONTRACTOR warrants that it has not employed or retained any company or person, other than a bona fide employee working solely for the CONTRACTOR, to solicit or secure this Agreement, and that it has not paid or agreed to pay any person, company, corporation, individual or firm, other than a bona fide employee working solely for CONTRACTOR, any fee, commission, percentage, gift, or other consideration contingent upon or resulting from the award or making of this Agreement. For the breach or violation of this provision, the CITY shall have the right to terminate the Agreement without liability at its discretion, to deduct from the contract price, or otherwise recover the full amount of such fee, commission, percentage, gift or consideration.

13.6 Notice. Whenever any party desires to give notice unto any other party, it must be given by written notice, sent by registered United States mail, with return receipt requested, addressed to the party for whom it is intended and the remaining party, at the places last specified, and the places for giving of notice shall remain such until they shall have been changed by written notice in compliance with the provisions of this section. For the present, the CONTRACTOR and the CITY designate the following as

the respective places for giving of notice:

CITY: W. Ajibola Balogun, City Administrator  
City of West Park  
1965 S. State Road 7  
West Park, Florida 33023

Copy To: Burnadette Norris-Weeks, City Attorney  
Burnadette Norris-Weeks, P.A.  
401 North Avenue of the Arts  
Fort Lauderdale, Florida 33311

CONTRACTOR:

13.7 Binding Authority. Each person signing this Agreement on behalf of either party individually warrants that he or she has full legal power to execute this Agreement on behalf of the party for whom he or she is signing, and to bind and obligate such party with respect to all provisions contained in this Agreement.

13.8 Exhibits. Each Exhibit referred to in this Agreement forms an essential part of this Agreement. The exhibits if not physically attached should be treated as part of this Agreement and are incorporated herein by reference.

13.9 Headings. Headings herein are for convenience of reference only and shall not be considered on any interpretation of this Agreement.

13.10 Severability. If any provision of this Agreement or application thereof to any person or situation shall, to any extent, be held invalid or unenforceable, the remainder of this Agreement, and the application of such provisions to persons or situations other than those as to which it shall have been held invalid or unenforceable shall not be affected thereby, and shall continue in full force and effect, and be enforced to the fullest extent permitted by law.

13.11 Governing Law. This Agreement shall be governed by the laws of the State of Florida with venue lying in Broward County, Florida.

13.12 Disputes. Any claim, objection, or dispute arising out of the terms of this Agreement shall be litigated in the Seventeenth Judicial Circuit Court in and for Broward County.

13.13 Attorney's Fees. To the extent authorized by law, in the event that either party brings suit for enforcement of this Agreement, the prevailing party shall be entitled to attorney's fees and court costs in addition to any other remedy afforded by law.

13.14 Extent of Agreement. This Agreement together with Contract Documents, attached as an Exhibit hereto, as amended herein above represents the entire and integrated agreement between the CITY and the CONTRACTOR and supersedes all prior negotiations, representations or agreements, either written or oral.

13.15 Waiver. Failure of the CITY to insist upon strict performance of any provision or condition of this Agreement, or to execute any right there in contained, shall not be construed as a waiver or relinquishment for the future of any such provision, condition, or right, but the same shall remain in full force and effect.

13.16 E-Verify. In accordance with Florida Statutes §448.095, the Contractor, prior to commencement of services or payment by the City, will provide to the City proof of participation/enrollment in the E-Verify system of the Department of Homeland Security. Evidence of participation/enrollment will be a printout of the Company's "Company Profile" page from the E-verify system. Failure to be continually enrolled and participating in the E-Verify program will be a breach of contract which will be grounds for immediate termination of the contract by the City. The Contractor will not hire any employee who has not been vetted through E-Verify. The Contractor may not subcontract any work for the City to any subcontractor that has not provided an affidavit stating that the subcontractor does not employ, contract with or subcontract with an unauthorized alien.

13.17 Scrutinized Companies. Contractor hereby certifies that it: a) has not been placed on the Scrutinized Companies that Boycott Israel List, nor is engaged in a boycott of Israel; b) has not been placed on the Scrutinized Companies with Activities in Sudan List nor the Scrutinized Companies with Activities in the Iran Petroleum Energy Sector List; and c) has not been engaged in business operations in Cuba or Syria. If City determined that Contractor has falsely certified facts under this paragraph or if Contractor is found to have been placed on the Scrutinized Companies Lists or is engaged in a boycott of Israel after the execution of this Agreement, City will have all rights and remedies to terminate this Agreement consistent with Section 287.135, Florida Statutes, as amended. The City reserves all rights to waive the certifications required by this paragraph on a case-by-case exception basis pursuant to Section 287.135, Florida Statutes, as amended. City reserves all rights to waive the certifications required by this paragraph on a case-by-case exception basis pursuant to Section 287.135, Florida Statutes, as amended.

Contractor shall not enter into a contract with an entity which would give access to an individual's personal identifying information if: (1) the entity is owned by the government of a foreign country of concern; (2) the government of a foreign country of concern has a controlling interest in the entity; or (3) the entity is organized under the laws or has its principal place of business in a foreign country of concern Section 287.138(2) (a)-(c), Fla. Stat. (2023), under Chapter 2023-33, Laws of Florida.

**(This space intentionally left blank)**

IN WITNESS OF THE FOREGOING, the parties have set their hands and seals the day and year first written above.

CITY OF WEST PARK

ATTEST:

\_\_\_\_\_  
Alexandra Grant, City Clerk

BY: \_\_\_\_\_  
Felicia Brunson., Mayor

APPROVED AS TO FORM

\_\_\_\_\_  
Burnadette Norris-Weeks, City Attorney

\_\_\_\_\_  
W. Ajibola Balogun, City  
Administrator

CONTRACTOR

WITNESSES:

\_\_\_\_\_

BY: \_\_\_\_\_

\_\_\_\_\_

ATTEST:

\_\_\_\_\_  
SECRETARY

STATE OF FLORIDA        )  
  )SS:  
COUNTY OF BROWARD    )

BEFORE ME, an officer duly authorized by law to administer oaths and take acknowledgments, personally appeared \_\_\_\_\_ as \_\_\_\_\_, of \_\_\_\_\_, a Florida corporation, and acknowledged executed the foregoing Agreement as the proper official of \_\_\_\_\_, for the use and purposes mentioned in it and affixed the official seal of the corporation, and that the instrument is the act and deed of that corporation.

IN WITNESS OF THE FOREGOING, I have set my hand and official seal at in the State and County aforesaid on this \_\_ day of \_\_\_\_\_, 2024.

\_\_\_\_\_  
NOTARY PUBLIC

My Commission Expires:

See attached document for Exhibit "A"

Invitation for Bid - ITB No: 24-0409  
(Citywide Sidewalk Restoration and ADA Compliance - Phase 2)

**(This space intentionally left blank)**

See attached document for Exhibit "B"

(Contractor's Bid in Response to ITB 24-0409 - Dated\_\_\_\_\_, 2024)

**(This space intentionally left blank)**

SECTION 00610

PERFORMANCE BOND

STATE OF FLORIDA            )  
  : ss  
COUNTY OF BROWARD        )

**KNOW ALL MEN BY THESE PRESENTS**, that \_\_\_\_\_ as Principal, hereinafter called Contractor, and \_\_\_\_\_, as Surety, hereinafter called Surety, are held in firmly bound unto the City of West Park, as Obligee hereinafter called Owner, in the amount of \_\_\_\_\_ Dollars (\$ \_\_\_\_\_) for the payment whereof Contractor and Surety bind themselves, their heirs, executors, administrators, successors and assigns, jointly and severally, firmly by these presents.

**WHEREAS**, contractor has by written agreement dated \_\_\_\_\_, 20\_\_\_\_, entered into Contract with Owner for:

**Project Description** \_\_\_\_\_  
**City's Project No.:** \_\_\_\_\_

In accordance with Drawings and Specifications prepared by \_\_\_\_\_ which Contract is by reference made a part hereof and is hereinafter referred to as the Contract.

**NOW, THEREFORE, THE CONDITIONS OF THIS OBLIGATION ARE SUCH**, that, if the Principal shall in all respects promptly and faithfully perform and comply with the terms and conditions of said Contract and his obligations thereunder and shall indemnify the Owner and the Consulting Engineer and save either or all of them harmless against and from all costs, expenses and damages arising from the performance of said Contract or the repair of any work thereunder, then this obligation shall be void; otherwise, this Bond shall remain in full force and effect, in accordance with the following terms and conditions:

- A. The Principal and Surety jointly and severally agree to pay the Owner any difference between the sum of which the said Principal would be entitled on the completion of the Contract, and that sum which the Owner may be obliged to pay for the completion of said work by Contractor or otherwise, and any damages, direct or indirect or consequential,

which the said Owner may sustain on account of such work, or on account of the failure of said Contractor to property and in all things, keep and excuse all of the provision of said Contract.

- B. And this Bond shall remain in full force and effect for a period of one (1) year from the date of acceptance of the project by the Owner and shall provide that the Contractor guarantees to repair or replace for said period of one (1) year all work performed and materials and equipment furnished that were not performed or furnished according to the terms of the Contract, and shall make good, defects thereof which have become apparent before the expiration of said period of one (1) year. If any part of the project, in the judgment of the Owner, for the reasons above stated needs to be replaced, repaired or made good during that time, the Owner shall notify the Contractor in writing. If the Contractor refuses or neglects to do such work within five (5) days from the date of service of such Notice, the Owner shall have the work done by others and the cost thereof shall be paid by the Contractor or his Surety.
- C. And the said Surety, for value received hereby stipulates and agrees that no change, extension of time, alteration or addition to the terms of the Contract or to the work to be performed thereunder or the specifications accompanying the same shall in any way affects its obligations on this board, and it does hereby waive Notice of any change, extension of time, alteration or addition to the terms of the Contract or to the work or to the Specifications.
- D. The Surety represents and warrants to the Owner that they have a Best's Key Rating Guide General Policyholder's Rating of "\_\_\_\_\_" and Financial Category of "Class\_\_\_\_\_."

**IN WITNESS WHEREOF**, the above bounded parties have executed this instrument under their several seals, this \_\_\_\_ day of \_\_\_\_\_, A.D., 20\_\_\_\_, the name and corporate seal of each corporate party being hereto affixed and these presents duly signed by its undersigned representative, pursuant to authority of its governing body.

WITNESSES: (If Sole Ownership or Partnership, two (2) witnesses required).  
(If Corporation, Secretary Only will attest and affix seal).

WITNESSES:

\_\_\_\_\_

PRINCIPAL:

\_\_\_\_\_  
Signature of Authorized Officer (Affix Seal)

\_\_\_\_\_  
Title

\_\_\_\_\_  
Business Address

\_\_\_\_\_  
City, State & Zip Code

WITNESSES:

---

---

SURETY:

---

Corporate Surety

---

Title

---

Business Address

---

City, State & Zip Code

---

Name of Local Insurance Agency

**END OF SECTION**

**CERTIFICATES AS TO CORPORATE PRINCIPAL**

I, \_\_\_\_\_, certify that I am the Secretary of the Corporation named as Principal in the within Bond; that \_\_\_\_\_ who signed the said bond on behalf of the Principal, was then \_\_\_\_\_ of said Corporation; that I know his signature, and his signature hereto is genuine; and that said bond was duly signed, sealed, and attested for and on behalf of said Corporation by authority of its governing body.

\_\_\_\_\_  
Secretary (Corporate Seal)

STATE OF FLORIDA        )  
                                      : ss  
COUNTY OF BROWARD    )

Before me, a Notary Public, duly commissioned, qualified and acting, personally appeared \_\_\_\_\_ to me well known, who being by me first duly sworn upon oath, says that he is the Attorney-in-Fact, for the \_\_\_\_\_ and that he has been authorized by \_\_\_\_\_ to execute the foregoing bond on behalf of the Contractor named therein in favor of the City of West Park, Florida.

Sworn and subscribed to before me this \_\_\_\_\_ day of \_\_\_\_\_, 20\_\_ A.D.  
(Attach Power of Attorney)

\_\_\_\_\_  
Notary Public – State of Florida At Large  
My Commission Expires:

**END OF SECTION**

SECTION 00620

PAYMENT BOND

STATE OF FLORIDA            )  
  : ss  
COUNTY OF BROWARD        )

**KNOW ALL MEN BY THESE PRESENTS**, that \_\_\_\_\_  
as Principal, hereinafter called Contractor, and \_\_\_\_\_, as Surety,  
hereinafter called Surety, are held and firmly bound unto the CITY OF WEST PARK, as Obligee,  
hereinafter called Owner, in the amount of \_\_\_\_\_ Dollars (\$ \_\_\_\_\_) for the  
payment whereof Contractor and Surety bind themselves, their heirs, executors, administrators, successors  
and assigns, jointly and severally, firmly by these presents.

**WHEREAS**, contractor has by written agreement dated \_\_\_\_\_, 20\_\_\_\_,  
entered into a Contract with Owner for:

**Project Description:** \_\_\_\_\_  
**City's Project No.:** \_\_\_\_\_

In accordance with Drawings and Specifications prepared by \_\_\_\_\_, which Contract  
is by reference made a part hereof and is hereinafter referred to as the Contract.

**NOW, THEREFORE, THE CONDITIONS OF THIS OBLIGATION ARE SUCH**, that, if  
the Principal shall promptly make payment to all claimants, as herein below defined, then this obligation  
shall be void; otherwise, this Bond shall remain in full force and effect, subject to the following terms and  
conditions:

- A. A claimant is defined as any person supplying the Principal with labor, material and supplies, used directly or indirectly by the said Principal or any subcontractor in the prosecution of the work provided for in said Contract, and is further defined in Section 255.05(1) of the Florida Statutes.
- B. The above named Principal and Surety hereby jointly and severally agree with the Owner that every claimant as herein defined, who has not been paid in full before the expiration of a period of ninety (90) days after performance of the labor or after complete delivery of materials and supplies by such claimant, may sue on this Bond for the use of such claimant, prosecute the suit to final judgment for such sum or sums as may be justly due

claimant, and have execution thereon. The Owner shall not be liable for the payment of any costs or expenses of any such suit.

C. No suit or action shall be commenced hereunder by any claimant:

1. Unless claimant, other than one having a direct contract with the Principal, shall within forty-five (45) days after beginning to furnish labor, materials or supplies for the prosecution of the work, furnish the Principal with a notice that he intends to look to this bond for protection.
2. Unless claimant, other than one having a direct contract with the Principal, shall within ninety (90) days after such claimant's performance of the labor or complete delivery of materials and supplies, deliver to the Principal written notice of the performance of such labor or delivery of such material and supplies and the nonpayment therefore.
3. After the expiration of one (1) year from the performance of the labor or completion of delivery of the materials and supplies; it being understood, however, that if any limitation embodied in this Bond is prohibited by any law controlling the construction hereof such limitations shall be deemed to be amended so as to be equal to the minimum period of limitation permitted by such law.
4. Other than in a state court of competent jurisdiction in and for the county or other political subdivision of the state in which the project, or any part thereof, is situated, or in the United States District Court for the district in which the project, or any part thereof, is situated, and not elsewhere.

A. The Principal and the Surety jointly and severally, shall repay the Owner any sum which the Owner may be compelled to pay because of any lien for labor or materials furnished for any work included in or provided by said Contract.

B. The Surety, for value received, hereby stipulates and agrees that no change, extension of time, alteration of or addition to the terms of the Contract or to the work to be performed thereunder or the Specifications applicable thereto shall in any way affect its obligations on this Bond, and the Surety hereby waives notice of any such change, extension of time, alterations of or addition to the terms of the Contract, or to the work or to the Specifications.

C. The Surety represents and warrants to the Owner that they have a Best's Key Rating Guide General Policyholder's Rating of "\_\_\_\_\_ " and Financial Category of "Class\_\_\_\_\_."

**IN WITNESS WHEREOF**, the above bounded parties have executed this instrument under their several seals, this \_\_\_\_\_ day of \_\_\_\_\_, A.D., 20\_\_\_\_, the name and corporate seal of each corporate party being hereto affixed and these presents duly signed by its undersigned representative, pursuant to authority of its governing body.

WITNESSES: (If Sole Ownership or Partnership, two (2) witnesses required).  
(If Corporation, Secretary Only will attest and affix seal).

WITNESSES:

**PRINCIPAL:**

\_\_\_\_\_

\_\_\_\_\_  
Signature of Authorized Officer (Affix Seal)

\_\_\_\_\_  
Title

\_\_\_\_\_  
Business Address

\_\_\_\_\_  
City, State & Zip Code

WITNESSES:

**SURETY:**

\_\_\_\_\_

\_\_\_\_\_  
Corporate Surety

\_\_\_\_\_  
Title

\_\_\_\_\_  
Business Address

\_\_\_\_\_  
City, State & Zip Code

\_\_\_\_\_  
Name of Local Insurance Agency

**END OF SECTION**

SECTION 00650

CERTIFICATE OF INSURANCE

(Sample)

THIS IS TO CERTIFY THAT THE \_\_\_\_\_  
(Insurance Company)

Address \_\_\_\_\_

of \_\_\_\_\_

has issued policies of insurance, as described below and identified by a policy number, to the insured named below; and to certify that such policies are in full force and effect at this time. It is agreed that none of these policies will be canceled or changed so as to affect the interest(s) of the City of West Park (hereinafter sometimes called the Owner) until thirty (30) days after written notice of such cancellation or change has been delivered to the Engineer: \_\_\_\_\_

Insured \_\_\_\_\_

Address \_\_\_\_\_

Status of Insured: \_\_\_\_\_ Corporation \_\_\_\_\_ Partnership \_\_\_\_\_ Individual

Location of Operations Insured \_\_\_\_\_

Description of Work:

**Project Description:** \_\_\_\_\_  
**City's Project No.:** \_\_\_\_\_

**INSURANCE POLICIES IN FORCE:**

<b>Forms of Coverage</b>	<b>Policy Number</b>	<b>Exp. Date</b>
*Workers' Comp./Employer's Liability	_____	_____
+Comprehensive Automobile Liability	_____	_____
°Comprehensive General Liability	_____	_____
+Excess Liability	_____	_____
Other (Please specify type: _____)	_____	_____

\_\_\_\_\_

**POLICY INCLUDES COVERAGE FOR:****YES****NO**

- |    |   |       |       |
|----|---|-------|-------|
| 1. | Additional Insured: Owner & Engineer  | _____ | _____ |
| 2. | *Liability under the United States<br>Longshoremen's and Harbor Workers'<br>Compensation Act.               | _____ | _____ |
| 3. | +All owned, hired, or non-owner automotive<br>equipment used in connection with work<br>done for the Owner. | _____ | _____ |
| 4. | Contractual Liability   | _____ | _____ |
| 5. | Damage caused by explosion, collapse or<br>structural injury, and damage to under-<br>ground utilities.     | _____ | _____ |
| 6. | Products/Completed Operations   | _____ | _____ |
| 7. | Owners and Contractors Protective Liability   | _____ | _____ |
| 8. | Personal Injury Liability   | _____ | _____ |
| 9. | +Excess Liability applies excess of:  | _____ | _____ |
|    | (a) Employers Liability   | _____ | _____ |
|    | (b) Comprehensive General Liability   | _____ | _____ |
|    | (c) Comprehensive Automobile Liability  | _____ | _____ |

**TYPES OF POLICY****FORMS OF COVERAGE****LIMITS OF LIABILITY**

Workers' Compensation	Bodily Injury	\$	Statutory
Employers Liability	Bodily Injury	\$_____	Each Accident
	Disease	\$_____	Each Person
	Disease	\$_____	Policy Limit
Comprehensive Auto Liability	Combined Single Limit BI/PD	\$_____	Each Accident
Comprehensive General Liability	Bodily Injury	\$_____	Each Occurrence
		\$_____	Aggregate
	Property Damage	\$_____	Each Occurrence

OR

\$\_\_\_\_\_Aggregate

Combined Single  
Limit BI/PD

\$\_\_\_\_\_Each Occurrence

\$\_\_\_\_\_Aggregate

Excess Liability

Combined Single

Limit BI/PD

\$\_\_\_\_\_Aggregate

Other

The Insurance Company hereby agrees to deliver, within ten (10) days, two (2) copies of the above policies to the Engineer when so requested.

NOTE: Entries on this certificate are limited to the Authorized Agent or Insurance Company Representative.

Date \_\_\_\_\_

(SEAL) \_\_\_\_\_

Insurance Company

Issued at \_\_\_\_\_

Authorized Representative

Insurance Agent or Company

-Send original to:

\_\_\_\_\_  
\_\_\_\_\_  
\_\_\_\_\_

-Send two (2) copies to:

**Attention: \_\_\_\_\_, Principal in Charge**

**City of West Park  
City Clerk's Office  
1965 South State Road 7  
West Park, Florida 33023**

**Attention: W. Ajibola Balogun, City Manager**

**END OF SECTION**

SECTION 00660

ACKNOWLEDEMENT OF CONFORMANCE WITH OSHA

TO THE CITY OF WEST PARK:

We, \_\_\_\_\_, hereby acknowledge and agree that as Contractors for the construction of \_\_\_\_\_, Engineer's Project \_\_\_\_\_, within the limits of the City of West Park, Florida, that we have the sole responsibility for compliance with all the requirements of the Federal Occupational Safety and Health Act of 1970, and all State and Local Safety and Health regulations, and agree to indemnify and hold harmless the City of West Park and its Consulting Engineers against any and all legal liability or loss the City or the Engineer may incur due to \_\_\_\_\_ failure to comply with such act.

\_\_\_\_\_  
ATTEST

\_\_\_\_\_  
CONTRACTOR

BY: \_\_\_\_\_  
NAME

\_\_\_\_\_  
ATTEST

\_\_\_\_\_  
DATE

**END OF SECTION**

SECTION 00665

TRENCH SAFETY ACT COMPLIANCE

Bidder acknowledges that the Florida Trench Safety Act, Section 553.60 et seq., which became effective October 1, 1990, shall be in effect during the period of construction for the project. The Bidder, by signing and submitting the bids, in writing, assuring that it will perform any trench excavation in accordance with applicable trench safety standards. The bidder further identifies the following separate item costs of compliance with the applicable trench safety standards as well as the methods of compliance:

**Methods of Compliance**

\_\_\_\_\_  
\_\_\_\_\_  
\_\_\_\_\_

(fill in methods)

Total \$ \_\_\_\_\_

Bidder acknowledges that this cost is included in the applicable items of the Proposal and in the Grand Total Bid Price. Failure to complete the above will result in the bid being declared non-responsive.

The Bidder is, and the Owner and Engineer are not, responsible to review or assess Bidder's safety precautions, programs or costs, or the means, methods, techniques or technique adequacy, reasonable of cost, sequences or procedures of any safety precaution, program or cost, including but not limited to, compliance with any and all requirements of Florida Statute Section 553.60 et seq. cited as the "Trench Safety Act". Bidder is, and the Owner and Engineer are not, responsible to determine of any safety or safety related standards apply to the project, including but not limited tom the "Trench Safety Act".

\_\_\_\_\_  
Signature of Authorized Representative (Manual)

\_\_\_\_\_  
Name of Authorized Representative (Typed or Printed)

Sworn to and subscribed before me in the Sate and County first mentioned above of the \_\_\_\_\_ day of \_\_\_\_\_, 20\_\_\_\_.

\_\_\_\_\_  
(affix seal)  
Notary Public

\_\_\_\_\_  
My Commission Expires:

**END OF SECTION**

## SECTION 00700

### GENERAL CONDITIONS

#### ARTICLE 1 – DEFINITIONS AND TERMINOLOGY

##### 1.1 *Defined Terms*

- A. Wherever used in the Bidding Requirements or Contract Documents and printed with initial capital letters, the terms listed below will have the meanings indicated which are applicable to both the singular and plural thereof. In addition to terms specifically defined, terms with initial capital letters in the Contract Documents include references to identified articles and paragraphs, and the titles of other documents or forms.
1. *Addenda*—Written or graphic instruments issued prior to the opening of Bids which clarify, correct, or change the Bidding Requirements or the proposed Contract Documents.
  2. *Agreement*—The written instrument which is evidence of the agreement between Owner and Contractor covering the Work.
  3. *Application for Payment*—The form acceptable to Engineer which is to be used by Contractor during the course of the Work in requesting progress or final payments and which is to be accompanied by such supporting documentation as is required by the Contract Documents.
  4. *Asbestos*—Any material that contains more than one percent asbestos and is friable or is releasing asbestos fibers into the air above current action levels established by the United States Occupational Safety and Health Administration.
  5. *Bid*—The offer or proposal of a Bidder submitted on the prescribed form setting forth the prices for the Work to be performed.
  6. *Bidder*—The individual or entity who submits a Bid directly to Owner.
  7. *Bidding Documents*—The Bidding Requirements and the proposed Contract Documents (including all Addenda).
  8. *Bidding Requirements*—The advertisement or invitation to bid, Instructions to Bidders, Bid security of acceptable form, if any, and the Bid Form with any supplements.
  9. *Change Order*—A document recommended by Engineer which is signed by Contractor and Owner and authorizes an addition, deletion, or revision in the Work or an adjustment in the Contract Price or the Contract Times, issued on or after the Effective Date of the Agreement.

10. *Claim*—A demand or assertion by Owner or Contractor seeking an adjustment of Contract Price or Contract Times, or both, or other relief with respect to the terms of the Contract. A demand for money or services by a third party is not a Claim.
11. *Contract*—The entire and integrated written agreement between the Owner and Contractor concerning the Work. The Contract supersedes prior negotiations, representations, or agreements, whether written or oral.
12. *Contract Documents*—Those items so designated in the Agreement. Only printed or hard copies of the items listed in the Agreement are Contract Documents. Approved Shop Drawings, other Contractor submittals, and the reports and drawings of subsurface and physical conditions are not Contract Documents.
13. *Contract Price*—The moneys payable by Owner to Contractor for completion of the Work in accordance with the Contract Documents as stated in the Agreement (subject to the provisions of Paragraph 11.03 in the case of Unit Price Work).
14. *Contract Times*—The number of days or the dates stated in the Agreement to: (i) achieve Milestones, if any; (ii) achieve Substantial Completion; and (iii) complete the Work so that it is ready for final payment as evidenced by Engineer’s written recommendation of final payment.
15. *Contractor*—The individual or entity with whom Owner has entered into the Agreement.
16. *Cost of the Work*—See Paragraph 11.01 for definition.
17. *Drawings*—That part of the Contract Documents prepared or approved by Engineer which graphically shows the scope, extent, and character of the Work to be performed by Contractor. Shop Drawings and other Contractor submittals are not Drawings as so defined.
18. *Effective Date of the Agreement*—The date indicated in the Agreement on which it becomes effective, but if no such date is indicated, it means the date on which the Agreement is signed and delivered by the last of the two parties to sign and deliver.
19. *Engineer*—The individual or entity named as such in the Agreement. The term “engineer” used throughout also refers to the architect.
20. *Field Order*—A written order issued by Engineer which requires minor changes in the Work but which does not involve a change in the Contract Price or the Contract Times.
21. *General Requirements*—Sections of Division 1 of the Specifications.
22. *Hazardous Environmental Condition*—The presence at the Site of Asbestos, PCBs, Petroleum, Hazardous Waste, or Radioactive Material in such quantities or circumstances that may present a substantial danger to persons or property exposed thereto.

23. *Hazardous Waste*—The term Hazardous Waste shall have the meaning provided in Section 1004 of the Solid Waste Disposal Act (42 USC Section 6903) as amended from time to time.
24. *Laws and Regulations; Laws or Regulations*—Any and all applicable laws, rules, regulations, ordinances, codes, and orders of any and all governmental bodies, agencies, authorities, and courts having jurisdiction.
25. *Liens*—Charges, security interests, or encumbrances upon Project funds, real property, or personal property.
26. *Milestone*—A principal event specified in the Contract Documents relating to an intermediate completion date or time prior to Substantial Completion of all the Work.
27. *Notice of Award*—The written notice by Owner to the Successful Bidder stating that upon timely compliance by the Successful Bidder with the conditions precedent listed therein, Owner will sign and deliver the Agreement.
28. *Notice to Proceed*—A written notice given by Owner to Contractor fixing the date on which the Contract Times will commence to run and on which Contractor shall start to perform the Work under the Contract Documents.
29. *Owner*—The individual or entity with whom Contractor has entered into the Agreement and for whom the Work is to be performed.
30. *PCBs*—Polychlorinated biphenyls.
31. *Petroleum*—Petroleum, including crude oil or any fraction thereof which is liquid at standard conditions of temperature and pressure (60 degrees Fahrenheit and 14.7 pounds per square inch absolute), such as oil, petroleum, fuel oil, oil sludge, oil refuse, gasoline, kerosene, and oil mixed with other non-Hazardous Waste and crude oils.
32. *Progress Schedule*—A schedule, prepared and maintained by Contractor, describing the sequence and duration of the activities comprising the Contractor's plan to accomplish the Work within the Contract Times.
33. *Project*—The total construction of which the Work to be performed under the Contract Documents may be the whole, or a part.
34. *Project Manual*—The bound documentary information prepared for bidding and constructing the Work. A listing of the contents of the Project Manual, which may be bound in one or more volumes, is contained in the table(s) of contents.
35. *Radioactive Material*—Source, special nuclear, or byproduct material as defined by the Atomic Energy Act of 1954 (42 USC Section 2011 et seq.) as amended from time to time.

36. *Resident Project Representative*—The authorized representative of Engineer who may be assigned to the Site or any part thereof.
37. *Samples*—Physical examples of materials, equipment, or workmanship that are representative of some portion of the Work and which establish the standards by which such portion of the Work will be judged.
38. *Schedule of Submittals*—A schedule, prepared and maintained by Contractor, of required submittals and the time requirements to support scheduled performance of related construction activities.
39. *Schedule of Values*—A schedule, prepared and maintained by Contractor, allocating portions of the Contract Price to various portions of the Work and used as the basis for reviewing Contractor's Applications for Payment.
40. *Shop Drawings*—All drawings, diagrams, illustrations, schedules, and other data or information which are specifically prepared or assembled by or for Contractor and submitted by Contractor to illustrate some portion of the Work.
41. *Site*—Lands or areas indicated in the Contract Documents as being furnished by Owner upon which the Work is to be performed, including rights-of-way and easements for access thereto, and such other lands furnished by Owner which are designated for the use of Contractor.
42. *Specifications*—That part of the Contract Documents consisting of written requirements for materials, equipment, systems, standards and workmanship as applied to the Work, and certain administrative requirements and procedural matters applicable thereto.
43. *Subcontractor*—An individual or entity having a direct contract with Contractor or with any other Subcontractor for the performance of a part of the Work at the Site.
44. *Substantial Completion*—The time at which the Work (or a specified part thereof) has progressed to the point where, in the opinion of Engineer, the Work (or a specified part thereof) is sufficiently complete, in accordance with the Contract Documents, so that the Work (or a specified part thereof) can be utilized for the purposes for which it is intended. The terms "substantially complete" and "substantially completed" as applied to all or part of the Work refer to Substantial Completion thereof.
45. *Successful Bidder*—The Bidder submitting a responsive Bid to whom Owner makes an award.
46. *Supplementary Conditions*—That part of the Contract Documents which amends or supplements these General Conditions.
47. *Supplier*—A manufacturer, fabricator, supplier, distributor, materialman, or vendor having a direct contract with Contractor or with any Subcontractor to furnish materials or equipment to be incorporated in the Work by Contractor or Subcontractor.

48. *Underground Facilities*—All underground pipelines, conduits, ducts, cables, wires, manholes, vaults, tanks, tunnels, or other such facilities or attachments, and any encasements containing such facilities, including those that convey electricity, gases, steam, liquid petroleum products, telephone or other communications, cable television, water, wastewater, storm water, other liquids or chemicals, or traffic or other control systems.
49. *Unit Price Work*—Work to be paid for on the basis of unit prices.
50. *Work*—The entire construction or the various separately identifiable parts thereof required to be provided under the Contract Documents. Work includes and is the result of performing or providing all labor, services, and documentation necessary to produce such construction, and furnishing, installing, and incorporating all materials and equipment into such construction, all as required by the Contract Documents.
51. *Work Change Directive*—A written statement to Contractor issued on or after the Effective Date of the Agreement and signed by Owner and recommended by Engineer ordering an addition, deletion, or revision in the Work, or responding to differing or unforeseen subsurface or physical conditions under which the Work is to be performed or to emergencies. A Work Change Directive will not change the Contract Price or the Contract Times but is evidence that the parties expect that the change ordered or documented by a Work Change Directive will be incorporated in a subsequently issued Change Order following negotiations by the parties as to its effect, if any, on the Contract Price or Contract Times.

## 1.2 Terminology

- A. The words and terms discussed in Paragraph 1.02.B through F are not defined but, when used in the Bidding Requirements or Contract Documents, have the indicated meaning.

### B. Intent of Certain Terms or Adjectives:

1. The Contract Documents include the terms “as allowed,” “as approved,” “as ordered,” “as directed” or terms of like effect or import to authorize an exercise of professional judgment by Engineer. In addition, the adjectives “reasonable,” “suitable,” “acceptable,” “proper,” “satisfactory,” or adjectives of like effect or import are used to describe an action or determination of Engineer as to the Work. It is intended that such exercise of professional judgment, action, or determination will be solely to evaluate, in general, the Work for compliance with the information in the Contract Documents and with the design concept of the Project as a functioning whole as shown or indicated in the Contract Documents (unless there is a specific statement indicating otherwise). The use of any such term or adjective is not intended to and shall not be effective to assign to Engineer any duty or authority to supervise or direct the performance of the Work, or any duty or authority to undertake responsibility contrary to the provisions of Paragraph 9.09 or any other provision of the Contract Documents.

*C. Day:*

1. The word “day” means a calendar day of 24 hours measured from midnight to the next midnight.

*D. Defective:*

1. The word “defective,” when modifying the word “Work,” refers to Work that is unsatisfactory, faulty, or deficient in that it:
  - a. does not conform to the Contract Documents; or
  - b. does not meet the requirements of any applicable inspection, reference standard, test, or approval referred to in the Contract Documents; or
  - c. has been damaged prior to Engineer’s recommendation of final payment (unless responsibility for the protection thereof has been assumed by Owner at Substantial Completion in accordance with Paragraph 14.04 or 14.05).

*A. Furnish, Install, Perform, Provide:*

1. The word “furnish,” when used in connection with services, materials, or equipment, shall mean to supply and deliver said services, materials, or equipment to the Site (or some other specified location) ready for use or installation and in usable or operable condition.
2. The word “install,” when used in connection with services, materials, or equipment, shall mean to put into use or place in final position said services, materials, or equipment complete and ready for intended use.
3. The words “perform” or “provide,” when used in connection with services, materials, or equipment, shall mean to furnish and install said services, materials, or equipment complete and ready for intended use.
4. When “furnish,” “install,” “perform,” or “provide” is not used in connection with services, materials, or equipment in a context clearly requiring an obligation of Contractor, “provide” is implied.

- F. Unless stated otherwise in the Contract Documents, words or phrases that have a well-known technical or construction industry or trade meaning are used in the Contract Documents in accordance with such recognized meaning.

## **ARTICLE 2 – PRELIMINARY MATTERS**

### *2.1 Delivery of Bonds and Evidence of Insurance*

- A. When Contractor delivers the executed counterparts of the Agreement to Owner, Contractor shall also deliver to Owner such bonds as Contractor may be required to furnish.

- B. *Evidence of Insurance:* Before any Work at the Site is started, Contractor and Owner shall each deliver to the other, with copies to each additional insured identified in the Supplementary Conditions, certificates of insurance (and other evidence of insurance which either of them or any additional insured may reasonably request) which Contractor and Owner respectively are required to purchase and maintain in accordance with Article 5.

## 2.2 *Copies of Documents*

- A. Owner shall furnish to Contractor up to ten printed or hard copies of the Drawings and Project Manual. Additional copies will be furnished upon request at the cost of reproduction.

## 2.3 *Commencement of Contract Times; Notice to Proceed*

- A. The Contract Times will commence to run on the thirtieth day after the Effective Date of the Agreement or, if a Notice to Proceed is given, on the day indicated in the Notice to Proceed. A Notice to Proceed may be given at any time within 30 days after the Effective Date of the Agreement. In no event will the Contract Times commence to run later than the sixtieth day after the day of Bid opening or the thirtieth day after the Effective Date of the Agreement, whichever date is earlier.

## 2.4 *Starting the Work*

- A. Contractor shall start to perform the Work on the date when the Contract Times commence to run. No Work shall be done at the Site prior to the date on which the Contract Times commence to run.

## 2.5 *Before Starting Construction*

- A. *Preliminary Schedules:* Within 10 days after the Effective Date of the Agreement (unless otherwise specified in the General Requirements), Contractor shall submit to Engineer for timely review:
1. a preliminary Progress Schedule indicating the times (numbers of days or dates) for starting and completing the various stages of the Work, including any Milestones specified in the Contract Documents;
  2. a preliminary Schedule of Submittals; and
  3. a preliminary Schedule of Values for all of the Work which includes quantities and prices of items which when added together equal the Contract Price and subdivides the Work into component parts in sufficient detail to serve as the basis for progress payments during performance of the Work. Such prices will include an appropriate amount of overhead and profit applicable to each item of Work.

## 2.6 *Preconstruction Conference; Designation of Authorized Representatives*

- A. Before any Work at the Site is started, a conference attended by Owner, Contractor, Engineer, and others as appropriate will be held to establish a working understanding among the parties as to the Work and to discuss the schedules referred to in Paragraph 2.05.A, procedures for handling Shop Drawings and other submittals, processing Applications for Payment, and maintaining required records.
- B. At this conference Owner and Contractor each shall designate, in writing, a specific individual to act as its authorized representative with respect to the services and responsibilities under the Contract. Such individuals shall have the authority to transmit instructions, receive information, render decisions relative to the Contract, and otherwise act on behalf of each respective party.

### *2.7 Initial Acceptance of Schedules*

- A. At least 10 days before submission of the first Application for Payment a conference attended by Contractor, Engineer, and others as appropriate will be held to review for acceptability to Engineer as provided below the schedules submitted in accordance with Paragraph 2.05.A. Contractor shall have an additional 10 days to make corrections and adjustments and to complete and resubmit the schedules. No progress payment shall be made to Contractor until acceptable schedules are submitted to Engineer.
  - 1. The Progress Schedule will be acceptable to Engineer if it provides an orderly progression of the Work to completion within the Contract Times. Such acceptance will not impose on Engineer responsibility for the Progress Schedule, for sequencing, scheduling, or progress of the Work, nor interfere with or relieve Contractor from Contractor's full responsibility therefor.
  - 2. Contractor's Schedule of Submittals will be acceptable to Engineer if it provides a workable arrangement for reviewing and processing the required submittals.
  - 3. Contractor's Schedule of Values will be acceptable to Engineer as to form and substance if it provides a reasonable allocation of the Contract Price to component parts of the Work.

## **ARTICLE 3 – CONTRACT DOCUMENTS: INTENT, AMENDING, REUSE**

### *3.1 Intent*

- A. The Contract Documents are complementary; what is required by one is as binding as if required by all.
- B. It is the intent of the Contract Documents to describe a functionally complete project (or part thereof) to be constructed in accordance with the Contract Documents. Any labor, documentation, services, materials, or equipment that reasonably may be inferred from the Contract Documents or from prevailing custom or trade usage as being required to produce the indicated result will be provided whether or not specifically called for, at no additional cost to Owner.

- C. Clarifications and interpretations of the Contract Documents shall be issued by Engineer as provided in Article 9.

### 3.2 Reference Standards

#### A. Standards, Specifications, Codes, Laws, and Regulations

1. Reference to standards, specifications, manuals, or codes of any technical society, organization, or association, or to Laws or Regulations, whether such reference be specific or by implication, shall mean the standard, specification, manual, code, or Laws or Regulations in effect at the time of opening of Bids (or on the Effective Date of the Agreement if there were no Bids), except as may be otherwise specifically stated in the Contract Documents.
2. No provision of any such standard, specification, manual, or code, or any instruction of a Supplier, shall be effective to change the duties or responsibilities of Owner, Contractor, or Engineer, or any of their subcontractors, consultants, agents, or employees, from those set forth in the Contract Documents. No such provision or instruction shall be effective to assign to Owner, Engineer, or any of their officers, directors, members, partners, employees, agents, consultants, or subcontractors, any duty or authority to supervise or direct the performance of the Work or any duty or authority to undertake responsibility inconsistent with the provisions of the Contract Documents.

### 3.3 Reporting and Resolving Discrepancies

#### A. Reporting Discrepancies:

1. *Contractor's Review of Contract Documents Before Starting Work:* Before undertaking each part of the Work, Contractor shall carefully study and compare the Contract Documents and check and verify pertinent figures therein and all applicable field measurements. Contractor shall promptly report in writing to Engineer any conflict, error, ambiguity, or discrepancy which Contractor discovers, or has actual knowledge of, and shall obtain a written interpretation or clarification from Engineer before proceeding with any Work affected thereby.
2. *Contractor's Review of Contract Documents During Performance of Work:* If, during the performance of the Work, Contractor discovers any conflict, error, ambiguity, or discrepancy within the Contract Documents, or between the Contract Documents and (a) any applicable Law or Regulation, (b) any standard, specification, manual, or code, or (c) any instruction of any Supplier, then Contractor shall promptly report it to Engineer in writing. Contractor shall not proceed with the Work affected thereby (except in an emergency as required by Paragraph 6.16.A) until an amendment or supplement to the Contract Documents has been issued by one of the methods indicated in Paragraph 3.04.
3. Contractor shall not be liable to Owner or Engineer for failure to report any conflict, error, ambiguity, or discrepancy in the Contract Documents unless Contractor had actual knowledge thereof.

*B. Resolving Discrepancies:*

1. Except as may be otherwise specifically stated in the Contract Documents, the provisions of the Contract Documents shall take precedence in resolving any conflict, error, ambiguity, or discrepancy between the provisions of the Contract Documents and:
  - a. the provisions of any standard, specification, manual, or code, or the instruction of any Supplier (whether or not specifically incorporated by reference in the Contract Documents); or
  - b. the provisions of any Laws or Regulations applicable to the performance of the Work (unless such an interpretation of the provisions of the Contract Documents would result in violation of such Law or Regulation).

*3.4 Amending and Supplementing Contract Documents*

- A. The Contract Documents may be amended to provide for additions, deletions, and revisions in the Work or to modify the terms and conditions thereof by either a Change Order or a Work Change Directive.
- B. The requirements of the Contract Documents may be supplemented, and minor variations and deviations in the Work may be authorized, by one or more of the following ways:
  1. A Field Order;
  2. Engineer's approval of a Shop Drawing or Sample (subject to the provisions of Paragraph 6.17.D.3); or
  3. Engineer's written interpretation or clarification.

*3.5 Reuse of Documents*

- A. Contractor and any Subcontractor or Supplier shall not:
  1. have or acquire any title to or ownership rights in any of the Drawings, Specifications, or other documents (or copies of any thereof) prepared by or bearing the seal of Engineer or its consultants, including electronic media editions; or
  2. reuse any such Drawings, Specifications, other documents, or copies thereof on extensions of the Project or any other project without written consent of Owner and Engineer and specific written verification or adaptation by Engineer.
- B. The prohibitions of this Paragraph 3.05 will survive final payment, or termination of the Contract. Nothing herein shall preclude Contractor from retaining copies of the Contract Documents for record purposes.

*3.6 Electronic Data*

- A. Unless otherwise stated in the Supplementary Conditions, the data furnished by Owner or Engineer to Contractor, or by Contractor to Owner or Engineer, that may be relied upon are limited to the printed copies (also known as hard copies). Files in electronic media format of text, data, graphics, or other types are furnished only for the convenience of the receiving party. Any conclusion or information obtained or derived from such electronic files will be at the user's sole risk. If there is a discrepancy between the electronic files and the hard copies, the hard copies govern.
- B. Because data stored in electronic media format can deteriorate or be modified inadvertently or otherwise without authorization of the data's creator, the party receiving electronic files agrees that it will perform acceptance tests or procedures within 60 days, after which the receiving party shall be deemed to have accepted the data thus transferred. Any errors detected within the 60-day acceptance period will be corrected by the transferring party.
- C. When transferring documents in electronic media format, the transferring party makes no representations as to long term compatibility, usability, or readability of documents resulting from the use of software application packages, operating systems, or computer hardware differing from those used by the data's creator.

## **ARTICLE 4 – AVAILABILITY OF LANDS; SUBSURFACE AND PHYSICAL CONDITIONS; HAZARDOUS ENVIRONMENTAL CONDITIONS; REFERENCE POINTS**

### *4.1 Availability of Lands*

- A. Owner shall furnish the Site. Owner shall notify Contractor of any encumbrances or restrictions not of general application but specifically related to use of the Site with which Contractor must comply in performing the Work. Owner will obtain in a timely manner and pay for easements for permanent structures or permanent changes in existing facilities. If Contractor and Owner are unable to agree on entitlement to or on the amount or extent, if any, of any adjustment in the Contract Price or Contract Times, or both, as a result of any delay in Owner's furnishing the Site or a part thereof, Contractor may make a Claim therefor as provided in Paragraph 10.05.
- B. Upon reasonable written request, Owner shall furnish Contractor with a current statement of record legal title and legal description of the lands upon which the Work is to be performed and Owner's interest therein as necessary for giving notice of or filing a mechanic's or construction lien against such lands in accordance with applicable Laws and Regulations.
- C. Contractor shall provide for all additional lands and access thereto that may be required for temporary construction facilities or storage of materials and equipment.

### *4.2 Subsurface and Physical Conditions*

#### *A. Reports and Drawings:* The Supplementary Conditions identify:

1. those reports known to Owner of explorations and tests of subsurface conditions at or contiguous to the Site; and

2. those drawings known to Owner of physical conditions relating to existing surface or subsurface structures at the Site (except Underground Facilities).
- B. *Limited Reliance by Contractor on Technical Data Authorized:* Contractor may rely upon the accuracy of the “technical data” contained in such reports and drawings, but such reports and drawings are not Contract Documents. Such “technical data” is identified in the Supplementary Conditions. Except for such reliance on such “technical data,” Contractor may not rely upon or make any claim against Owner or Engineer, or any of their officers, directors, members, partners, employees, agents, consultants, or subcontractors with respect to:
1. the completeness of such reports and drawings for Contractor’s purposes, including, but not limited to, any aspects of the means, methods, techniques, sequences, and procedures of construction to be employed by Contractor, and safety precautions and programs incident thereto; or
  2. other data, interpretations, opinions, and information contained in such reports or shown or indicated in such drawings; or
  3. any Contractor interpretation of or conclusion drawn from any “technical data” or any such other data, interpretations, opinions, or information.

#### 4.3 *Differing Subsurface or Physical Conditions*

- A. *Notice:* If Contractor believes that any subsurface or physical condition that is uncovered or revealed either:
1. is of such a nature as to establish that any “technical data” on which Contractor is entitled to rely as provided in Paragraph 4.02 is materially inaccurate; or
  2. is of such a nature as to require a change in the Contract Documents; or
  3. differs materially from that shown or indicated in the Contract Documents; or
  4. is of an unusual nature, and differs materially from conditions ordinarily encountered and generally recognized as inherent in work of the character provided for in the Contract Documents;

then Contractor shall, promptly after becoming aware thereof and before further disturbing the subsurface or physical conditions or performing any Work in connection therewith (except in an emergency as required by Paragraph 6.16.A), notify Owner and Engineer in writing about such condition. Contractor shall not further disturb such condition or perform any Work in connection therewith (except as aforesaid) until receipt of written order to do so.

- B. *Engineer’s Review:* After receipt of written notice as required by Paragraph 4.03.A, Engineer will promptly review the pertinent condition, determine the necessity of

Owner's obtaining additional exploration or tests with respect thereto, and advise Owner in writing (with a copy to Contractor) of Engineer's findings and conclusions.

*C. Possible Price and Times Adjustments:*

1. The Contract Price or the Contract Times, or both, will be equitably adjusted to the extent that the existence of such differing subsurface or physical condition causes an increase or decrease in Contractor's cost of, or time required for, performance of the Work; subject, however, to the following:
  - a. such condition must meet any one or more of the categories described in Paragraph 4.03.A; and
  - b. with respect to Work that is paid for on a unit price basis, any adjustment in Contract Price will be subject to the provisions of Paragraphs 9.07 and 11.03.
2. Contractor shall not be entitled to any adjustment in the Contract Price or Contract Times if:
  - a. Contractor knew of the existence of such conditions at the time Contractor made a final commitment to Owner with respect to Contract Price and Contract Times by the submission of a Bid or becoming bound under a negotiated contract; or
  - b. the existence of such condition could reasonably have been discovered or revealed as a result of any examination, investigation, exploration, test, or study of the Site and contiguous areas required by the Bidding Requirements or Contract Documents to be conducted by or for Contractor prior to Contractor's making such final commitment; or
  - c. Contractor failed to give the written notice as required by Paragraph 4.03.A.
3. If Owner and Contractor are unable to agree on entitlement to or on the amount or extent, if any, of any adjustment in the Contract Price or Contract Times, or both, a Claim may be made therefor as provided in Paragraph 10.05. However, neither Owner or Engineer, or any of their officers, directors, members, partners, employees, agents, consultants, or subcontractors shall be liable to Contractor for any claims, costs, losses, or damages (including but not limited to all fees and charges of engineers, architects, attorneys, and other professionals and all court or arbitration or other dispute resolution costs) sustained by Contractor on or in connection with any other project or anticipated project.

*4.4 Underground Facilities*

- A. *Shown or Indicated:* The information and data shown or indicated in the Contract Documents with respect to existing Underground Facilities at or contiguous to the Site is based on information and data furnished to Owner or Engineer by the owners of such Underground Facilities, including Owner, or by others. Unless it is otherwise expressly provided in the Supplementary Conditions:

1. Owner and Engineer shall not be responsible for the accuracy or completeness of any such information or data provided by others; and
2. the cost of all of the following will be included in the Contract Price, and Contractor shall have full responsibility for:
  - a. reviewing and checking all such information and data;
  - b. locating all Underground Facilities shown or indicated in the Contract Documents;
  - c. coordination of the Work with the owners of such Underground Facilities, including Owner, during construction; and
  - d. the safety and protection of all such Underground Facilities and repairing any damage thereto resulting from the Work.

*B. Not Shown or Indicated:*

1. If an Underground Facility is uncovered or revealed at or contiguous to the Site which was not shown or indicated, or not shown or indicated with reasonable accuracy in the Contract Documents, Contractor shall, promptly after becoming aware thereof and before further disturbing conditions affected thereby or performing any Work in connection therewith (except in an emergency as required by Paragraph 6.16.A), identify the owner of such Underground Facility and give written notice to that owner and to Owner and Engineer. Engineer will promptly review the Underground Facility and determine the extent, if any, to which a change is required in the Contract Documents to reflect and document the consequences of the existence or location of the Underground Facility. During such time, Contractor shall be responsible for the safety and protection of such Underground Facility.
2. If Engineer concludes that a change in the Contract Documents is required, a Work Change Directive or a Change Order will be issued to reflect and document such consequences. An equitable adjustment shall be made in the Contract Price or Contract Times, or both, to the extent that they are attributable to the existence or location of any Underground Facility that was not shown or indicated or not shown or indicated with reasonable accuracy in the Contract Documents and that Contractor did not know of and could not reasonably have been expected to be aware of or to have anticipated. If Owner and Contractor are unable to agree on entitlement to or on the amount or extent, if any, of any such adjustment in Contract Price or Contract Times, Owner or Contractor may make a Claim therefor as provided in Paragraph 10.05.

*4.5 Reference Points*

- A. Owner shall provide engineering surveys to establish reference points for construction which in Engineer's judgment are necessary to enable Contractor to proceed with the Work. Contractor shall be responsible for laying out the Work, shall protect and preserve the established reference points and property monuments, and shall make no changes or relocations without the prior written approval of Owner. Contractor shall report to

Engineer whenever any reference point or property monument is lost or destroyed or requires relocation because of necessary changes in grades or locations, and shall be responsible for the accurate replacement or relocation of such reference points or property monuments by professionally qualified personnel.

#### 4.6 *Hazardous Environmental Condition at Site*

- A. *Reports and Drawings:* The Supplementary Conditions identify those reports and drawings known to Owner relating to Hazardous Environmental Conditions that have been identified at the Site.
- B. *Limited Reliance by Contractor on Technical Data Authorized:* Contractor may rely upon the accuracy of the “technical data” contained in such reports and drawings, but such reports and drawings are not Contract Documents. Such “technical data” is identified in the Supplementary Conditions. Except for such reliance on such “technical data,” Contractor may not rely upon or make any claim against Owner or Engineer, or any of their officers, directors, members, partners, employees, agents, consultants, or subcontractors with respect to:
1. the completeness of such reports and drawings for Contractor’s purposes, including, but not limited to, any aspects of the means, methods, techniques, sequences and procedures of construction to be employed by Contractor and safety precautions and programs incident thereto; or
  2. other data, interpretations, opinions and information contained in such reports or shown or indicated in such drawings; or
  3. any Contractor interpretation of or conclusion drawn from any “technical data” or any such other data, interpretations, opinions or information.
- C. Contractor shall not be responsible for any Hazardous Environmental Condition uncovered or revealed at the Site which was not shown or indicated in Drawings or Specifications or identified in the Contract Documents to be within the scope of the Work. Contractor shall be responsible for a Hazardous Environmental Condition created with any materials brought to the Site by Contractor, Subcontractors, Suppliers, or anyone else for whom Contractor is responsible.
- D. If Contractor encounters a Hazardous Environmental Condition or if Contractor or anyone for whom Contractor is responsible creates a Hazardous Environmental Condition, Contractor shall immediately: (i) secure or otherwise isolate such condition; (ii) stop all Work in connection with such condition and in any area affected thereby (except in an emergency as required by Paragraph 6.16.A); and (iii) notify Owner and Engineer (and promptly thereafter confirm such notice in writing). Owner shall promptly consult with Engineer concerning the necessity for Owner to retain a qualified expert to evaluate such condition or take corrective action, if any. Promptly after consulting with Engineer, Owner shall take such actions as are necessary to permit Owner to timely obtain required permits and provide Contractor the written notice required by Paragraph 4.06.E.

- E. Contractor shall not be required to resume Work in connection with such condition or in any affected area until after Owner has obtained any required permits related thereto and delivered written notice to Contractor: (i) specifying that such condition and any affected area is or has been rendered safe for the resumption of Work; or (ii) specifying any special conditions under which such Work may be resumed safely. If Owner and Contractor cannot agree as to entitlement to or on the amount or extent, if any, of any adjustment in Contract Price or Contract Times, or both, as a result of such Work stoppage or such special conditions under which Work is agreed to be resumed by Contractor, either party may make a Claim therefor as provided in Paragraph 10.05.
- F. If after receipt of such written notice Contractor does not agree to resume such Work based on a reasonable belief it is unsafe, or does not agree to resume such Work under such special conditions, then Owner may order the portion of the Work that is in the area affected by such condition to be deleted from the Work. If Owner and Contractor cannot agree as to entitlement to or on the amount or extent, if any, of an adjustment in Contract Price or Contract Times as a result of deleting such portion of the Work, then either party may make a Claim therefor as provided in Paragraph 10.05. Owner may have such deleted portion of the Work performed by Owner's own forces or others in accordance with Article 7.
- G. To the fullest extent permitted by Laws and Regulations, Owner shall indemnify and hold harmless Contractor, Subcontractors, and Engineer, and the officers, directors, members, partners, employees, agents, consultants, and subcontractors of each and any of them from and against all claims, costs, losses, and damages (including but not limited to all fees and charges of engineers, architects, attorneys, and other professionals and all court or arbitration or other dispute resolution costs) arising out of or relating to a Hazardous Environmental Condition, provided that such Hazardous Environmental Condition: (i) was not shown or indicated in the Drawings or Specifications or identified in the Contract Documents to be included within the scope of the Work, and (ii) was not created by Contractor or by anyone for whom Contractor is responsible. Nothing in this Paragraph 4.06.G shall obligate Owner to indemnify any individual or entity from and against the consequences of that individual's or entity's own negligence.
- H. To the fullest extent permitted by Laws and Regulations, Contractor shall indemnify and hold harmless Owner and Engineer, and the officers, directors, members, partners, employees, agents, consultants, and subcontractors of each and any of them from and against all claims, costs, losses, and damages (including but not limited to all fees and charges of engineers, architects, attorneys, and other professionals and all court or arbitration or other dispute resolution costs) arising out of or relating to a Hazardous Environmental Condition created by Contractor or by anyone for whom Contractor is responsible. Nothing in this Paragraph 4.06.H shall obligate Contractor to indemnify any individual or entity from and against the consequences of that individual's or entity's own negligence.
- I. The provisions of Paragraphs 4.02, 4.03, and 4.04 do not apply to a Hazardous Environmental Condition uncovered or revealed at the Site.

## **ARTICLE 5 – BONDS AND INSURANCE**

### *5.1 Performance, Payment, and Other Bonds*

- A. Contractor shall furnish performance and payment bonds, each in an amount at least equal to the Contract Price as security for the faithful performance and payment of all of Contractor's obligations under the Contract Documents. These bonds shall remain in effect until one year after the date when final payment becomes due or until completion of the correction period specified in Paragraph 13.07, whichever is later, except as provided otherwise by Laws or Regulations or by the Contract Documents. Contractor shall also furnish such other bonds as are required by the Contract Documents.
- B. All bonds shall be in the form prescribed by the Contract Documents except as provided otherwise by Laws or Regulations, and shall be executed by such sureties as are named in the list of "Companies Holding Certificates of Authority as Acceptable Sureties on Federal Bonds and as Acceptable Reinsuring Companies" as published in Circular 570 (amended) by the Financial Management Service, Surety Bond Branch, U.S. Department of the Treasury. All bonds signed by an agent or attorney-in-fact must be accompanied by a certified copy of that individual's authority to bind the surety. The evidence of authority shall show that it is effective on the date the agent or attorney-in-fact signed each bond.
- C. If the surety on any bond furnished by Contractor is declared bankrupt or becomes insolvent or its right to do business is terminated in any state where any part of the Project is located or it ceases to meet the requirements of Paragraph 5.01.B, Contractor shall promptly notify Owner and Engineer and shall, within 20 days after the event giving rise to such notification, provide another bond and surety, both of which shall comply with the requirements of Paragraphs 5.01.B and 5.02.

### *5.2 Licensed Sureties and Insurers*

- A. All bonds and insurance required by the Contract Documents to be purchased and maintained by Owner or Contractor shall be obtained from surety or insurance companies that are duly licensed or authorized in the jurisdiction in which the Project is located to issue bonds or insurance policies for the limits and coverages so required. Such surety and insurance companies shall also meet such additional requirements and qualifications as may be provided in the Supplementary Conditions.

### *5.3 Certificates of Insurance*

- A. Contractor shall deliver to Owner, with copies to each additional insured and loss payee identified in the Supplementary Conditions, certificates of insurance (and other evidence of insurance requested by Owner or any other additional insured) which Contractor is required to purchase and maintain.
- B. Owner shall deliver to Contractor, with copies to each additional insured and loss payee identified in the Supplementary Conditions, certificates of insurance (and other evidence of insurance requested by Contractor or any other additional insured) which Owner is required to purchase and maintain.
- C. Failure of Owner to demand such certificates or other evidence of Contractor's full compliance with these insurance requirements or failure of Owner to identify a deficiency

in compliance from the evidence provided shall not be construed as a waiver of Contractor's obligation to maintain such insurance.

- D. Owner does not represent that insurance coverage and limits established in this Contract necessarily will be adequate to protect Contractor.
- E. The insurance and insurance limits required herein shall not be deemed as a limitation on Contractor's liability under the indemnities granted to Owner in the Contract Documents.

#### *5.4 Contractor's Insurance*

- A. Contractor shall purchase and maintain such insurance as is appropriate for the Work being performed and as will provide protection from claims set forth below which may arise out of or result from Contractor's performance of the Work and Contractor's other obligations under the Contract Documents, whether it is to be performed by Contractor, any Subcontractor or Supplier, or by anyone directly or indirectly employed by any of them to perform any of the Work, or by anyone for whose acts any of them may be liable:
  - 1. claims under workers' compensation, disability benefits, and other similar employee benefit acts;
  - 2. claims for damages because of bodily injury, occupational sickness or disease, or death of Contractor's employees;
  - 3. claims for damages because of bodily injury, sickness or disease, or death of any person other than Contractor's employees;
  - 4. claims for damages insured by reasonably available personal injury liability coverage which are sustained:
    - a. by any person as a result of an offense directly or indirectly related to the employment of such person by Contractor, or
    - b. by any other person for any other reason;
  - 5. claims for damages, other than to the Work itself, because of injury to or destruction of tangible property wherever located, including loss of use resulting therefrom; and
  - 6. claims for damages because of bodily injury or death of any person or property damage arising out of the ownership, maintenance or use of any motor vehicle.
- B. The policies of insurance required by this Paragraph 5.04 shall:
  - 1. with respect to insurance required by Paragraphs 5.04.A.3 through 5.04.A.6 inclusive, be written on an occurrence basis, include as additional insureds (subject to any customary exclusion regarding professional liability) Owner and Engineer, and any other individuals or entities identified in the Supplementary Conditions, all of whom shall be listed as additional insureds, and include coverage for the respective officers, directors, members, partners, employees, agents, consultants, and subcontractors of

each and any of all such additional insureds, and the insurance afforded to these additional insureds shall provide primary coverage for all claims covered thereby;

2. include at least the specific coverages and be written for not less than the limits of liability provided in the Supplementary Conditions or required by Laws or Regulations, whichever is greater;
3. include contractual liability insurance covering Contractor's indemnity obligations under Paragraphs 6.11 and 6.20;
4. contain a provision or endorsement that the coverage afforded will not be canceled, materially changed or renewal refused until at least 30 days prior written notice has been given to Owner and Contractor and to each other additional insured identified in the Supplementary Conditions to whom a certificate of insurance has been issued (and the certificates of insurance furnished by the Contractor pursuant to Paragraph 5.03 will so provide);
5. remain in effect at least until final payment and at all times thereafter when Contractor may be correcting, removing, or replacing defective Work in accordance with Paragraph 13.07; and
6. include completed operations coverage:
  - a. Such insurance shall remain in effect for two years after final payment.
  - b. Contractor shall furnish Owner and each other additional insured identified in the Supplementary Conditions, to whom a certificate of insurance has been issued, evidence satisfactory to Owner and any such additional insured of continuation of such insurance at final payment and one year thereafter.

#### *5.5 Owner's Liability Insurance*

- A. In addition to the insurance required to be provided by Contractor under Paragraph 5.04, Owner, at Owner's option, may purchase and maintain at Owner's expense Owner's own liability insurance as will protect Owner against claims which may arise from operations under the Contract Documents.

#### *5.6 Property Insurance*

- A. Unless otherwise provided in the Supplementary Conditions, Owner shall purchase and maintain property insurance upon the Work at the Site in the amount of the full replacement cost thereof (subject to such deductible amounts as may be provided in the Supplementary Conditions or required by Laws and Regulations). This insurance shall:
  1. include the interests of Owner, Contractor, Subcontractors, and Engineer, and any other individuals or entities identified in the Supplementary Conditions, and the officers, directors, members, partners, employees, agents, consultants, and subcontractors of each and any of them, each of whom is deemed to have an insurable interest and shall be listed as a loss payee;

2. be written on a Builder's Risk "all-risk" policy form that shall at least include insurance for physical loss or damage to the Work, temporary buildings, falsework, and materials and equipment in transit, and shall insure against at least the following perils or causes of loss: fire, lightning, extended coverage, theft, vandalism and malicious mischief, earthquake, collapse, debris removal, demolition occasioned by enforcement of Laws and Regulations, water damage (other than that caused by flood), and such other perils or causes of loss as may be specifically required by the Supplementary Conditions.
  3. include expenses incurred in the repair or replacement of any insured property (including but not limited to fees and charges of engineers and architects);
  4. cover materials and equipment stored at the Site or at another location that was agreed to in writing by Owner prior to being incorporated in the Work, provided that such materials and equipment have been included in an Application for Payment recommended by Engineer;
  5. allow for partial utilization of the Work by Owner;
  6. include testing and startup; and
  7. be maintained in effect until final payment is made unless otherwise agreed to in writing by Owner, Contractor, and Engineer with 30 days written notice to each other loss payee to whom a certificate of insurance has been issued.
- B. Owner shall purchase and maintain such equipment breakdown insurance or additional property insurance as may be required by the Supplementary Conditions or Laws and Regulations which will include the interests of Owner, Contractor, Subcontractors, and Engineer, and any other individuals or entities identified in the Supplementary Conditions, and the officers, directors, members, partners, employees, agents, consultants and subcontractors of each and any of them, each of whom is deemed to have an insurable interest and shall be listed as a loss payee.
- C. All the policies of insurance (and the certificates or other evidence thereof) required to be purchased and maintained in accordance with this Paragraph 5.06 will contain a provision or endorsement that the coverage afforded will not be canceled or materially changed or renewal refused until at least 30 days prior written notice has been given to Owner and Contractor and to each other loss payee to whom a certificate of insurance has been issued and will contain waiver provisions in accordance with Paragraph 5.07.
- D. Owner shall not be responsible for purchasing and maintaining any property insurance specified in this Paragraph 5.06 to protect the interests of Contractor, Subcontractors, or others in the Work to the extent of any deductible amounts that are identified in the Supplementary Conditions. The risk of loss within such identified deductible amount will be borne by Contractor, Subcontractors, or others suffering any such loss, and if any of them wishes property insurance coverage within the limits of such amounts, each may purchase and maintain it at the purchaser's own expense.

- E. If Contractor requests in writing that other special insurance be included in the property insurance policies provided under this Paragraph 5.06, Owner shall, if possible, include such insurance, and the cost thereof will be charged to Contractor by appropriate Change Order. Prior to commencement of the Work at the Site, Owner shall in writing advise Contractor whether or not such other insurance has been procured by Owner.

### 5.7 *Waiver of Rights*

- A. Owner and Contractor intend that all policies purchased in accordance with Paragraph 5.06 will protect Owner, Contractor, Subcontractors, and Engineer, and all other individuals or entities identified in the Supplementary Conditions as loss payees (and the officers, directors, members, partners, employees, agents, consultants, and subcontractors of each and any of them) in such policies and will provide primary coverage for all losses and damages caused by the perils or causes of loss covered thereby. All such policies shall contain provisions to the effect that in the event of payment of any loss or damage the insurers will have no rights of recovery against any of the insureds or loss payees thereunder. Owner and Contractor waive all rights against each other and their respective officers, directors, members, partners, employees, agents, consultants and subcontractors of each and any of them for all losses and damages caused by, arising out of or resulting from any of the perils or causes of loss covered by such policies and any other property insurance applicable to the Work; and, in addition, waive all such rights against Subcontractors and Engineer, and all other individuals or entities identified in the Supplementary Conditions as loss payees (and the officers, directors, members, partners, employees, agents, consultants, and subcontractors of each and any of them) under such policies for losses and damages so caused. None of the above waivers shall extend to the rights that any party making such waiver may have to the proceeds of insurance held by Owner as trustee or otherwise payable under any policy so issued.
- B. Owner waives all rights against Contractor, Subcontractors, and Engineer, and the officers, directors, members, partners, employees, agents, consultants and subcontractors of each and any of them for:
  - 1. loss due to business interruption, loss of use, or other consequential loss extending beyond direct physical loss or damage to Owner's property or the Work caused by, arising out of, or resulting from fire or other perils whether or not insured by Owner; and
  - 2. loss or damage to the completed Project or part thereof caused by, arising out of, or resulting from fire or other insured peril or cause of loss covered by any property insurance maintained on the completed Project or part thereof by Owner during partial utilization pursuant to Paragraph 14.05, after Substantial Completion pursuant to Paragraph 14.04, or after final payment pursuant to Paragraph 14.07.
- C. Any insurance policy maintained by Owner covering any loss, damage or consequential loss referred to in Paragraph 5.07.B shall contain provisions to the effect that in the event of payment of any such loss, damage, or consequential loss, the insurers will have no rights of recovery against Contractor, Subcontractors, or Engineer, and the officers, directors, members, partners, employees, agents, consultants and subcontractors of each and any of them.

### *5.8 Receipt and Application of Insurance Proceeds*

- A. Any insured loss under the policies of insurance required by Paragraph 5.06 will be adjusted with Owner and made payable to Owner as fiduciary for the loss payees, as their interests may appear, subject to the requirements of any applicable mortgage clause and of Paragraph 5.08.B. Owner shall deposit in a separate account any money so received and shall distribute it in accordance with such agreement as the parties in interest may reach. If no other special agreement is reached, the damaged Work shall be repaired or replaced, the moneys so received applied on account thereof, and the Work and the cost thereof covered by an appropriate Change Order.
- B. Owner as fiduciary shall have power to adjust and settle any loss with the insurers unless one of the parties in interest shall object in writing within 15 days after the occurrence of loss to Owner's exercise of this power. If such objection be made, Owner as fiduciary shall make settlement with the insurers in accordance with such agreement as the parties in interest may reach. If no such agreement among the parties in interest is reached, Owner as fiduciary shall adjust and settle the loss with the insurers and, if required in writing by any party in interest, Owner as fiduciary shall give bond for the proper performance of such duties.

### *5.9 Acceptance of Bonds and Insurance; Option to Replace*

- A. If either Owner or Contractor has any objection to the coverage afforded by or other provisions of the bonds or insurance required to be purchased and maintained by the other party in accordance with Article 5 on the basis of non-conformance with the Contract Documents, the objecting party shall so notify the other party in writing within 10 days after receipt of the certificates (or other evidence requested) required by Paragraph 2.01.B. Owner and Contractor shall each provide to the other such additional information in respect of insurance provided as the other may reasonably request. If either party does not purchase or maintain all of the bonds and insurance required of such party by the Contract Documents, such party shall notify the other party in writing of such failure to purchase prior to the start of the Work, or of such failure to maintain prior to any change in the required coverage. Without prejudice to any other right or remedy, the other party may elect to obtain equivalent bonds or insurance to protect such other party's interests at the expense of the party who was required to provide such coverage, and a Change Order shall be issued to adjust the Contract Price accordingly.

### *5.10 Partial Utilization, Acknowledgment of Property Insurer*

- A. If Owner finds it necessary to occupy or use a portion or portions of the Work prior to Substantial Completion of all the Work as provided in Paragraph 14.05, no such use or occupancy shall commence before the insurers providing the property insurance pursuant to Paragraph 5.06 have acknowledged notice thereof and in writing effected any changes in coverage necessitated thereby. The insurers providing the property insurance shall consent by endorsement on the policy or policies, but the property insurance shall not be canceled or permitted to lapse on account of any such partial use or occupancy.

## **ARTICLE 6 – CONTRACTOR'S RESPONSIBILITIES**

### *6.1 Supervision and Superintendence*

- A. Contractor shall supervise, inspect, and direct the Work competently and efficiently, devoting such attention thereto and applying such skills and expertise as may be necessary to perform the Work in accordance with the Contract Documents. Contractor shall be solely responsible for the means, methods, techniques, sequences, and procedures of construction. Contractor shall not be responsible for the negligence of Owner or Engineer in the design or specification of a specific means, method, technique, sequence, or procedure of construction which is shown or indicated in and expressly required by the Contract Documents.
- B. At all times during the progress of the Work, Contractor shall assign a competent resident superintendent who shall not be replaced without written notice to Owner and Engineer except under extraordinary circumstances. Superintendent shall communicate clearly in English.

### *6.2 Labor; Working Hours*

- A. Contractor shall provide competent, suitably qualified personnel to survey and lay out the Work and perform construction as required by the Contract Documents. Contractor shall at all times maintain good discipline and order at the Site.
- B. Except as otherwise required for the safety or protection of persons or the Work or property at the Site or adjacent thereto, and except as otherwise stated in the Contract Documents, all Work at the Site shall be performed during regular working hours. Contractor will not permit the performance of Work on a Saturday, Sunday, or any legal holiday without Owner's written consent (which will not be unreasonably withheld) given after prior written notice to Engineer.

### *6.3 Services, Materials, and Equipment*

- A. Unless otherwise specified in the Contract Documents, Contractor shall provide and assume full responsibility for all services, materials, equipment, labor, transportation, construction equipment and machinery, tools, appliances, fuel, power, light, heat, telephone, water, sanitary facilities, temporary facilities, and all other facilities and incidentals necessary for the performance, testing, start-up, and completion of the Work.
- B. All materials and equipment incorporated into the Work shall be as specified or, if not specified, shall be of good quality and new, except as otherwise provided in the Contract Documents. All special warranties and guarantees required by the Specifications shall expressly run to the benefit of Owner. If required by Engineer, Contractor shall furnish satisfactory evidence (including reports of required tests) as to the source, kind, and quality of materials and equipment.
- C. All materials and equipment shall be stored, applied, installed, connected, erected, protected, used, cleaned, and conditioned in accordance with instructions of the applicable Supplier, except as otherwise may be provided in the Contract Documents.

### *6.4 Progress Schedule*

A. Contractor shall adhere to the Progress Schedule established in accordance with Paragraph 2.07 as it may be adjusted from time to time as provided below.

1. Contractor shall submit to Engineer for acceptance (to the extent indicated in Paragraph 2.07) proposed adjustments in the Progress Schedule that will not result in changing the Contract Times. Such adjustments will comply with any provisions of the General Requirements applicable thereto.
2. Proposed adjustments in the Progress Schedule that will change the Contract Times shall be submitted in accordance with the requirements of Article 12. Adjustments in Contract Times may only be made by a Change Order.

### 6.5 *Substitutes and "Or-Equals"*

A. All substitutions and "or-equal" products shall be submitted only in the bidding phase. If not approved during bidding they will not be reviewed or accepted during construction.

B. Whenever an item of material or equipment is specified or described in the Contract Documents by using the name of a proprietary item or the name of a particular Supplier, the specification or description is intended to establish the type, function, appearance, and quality required. Unless the specification or description contains or is followed by words reading that no like, equivalent, or "or-equal" item or no substitution is permitted, other items of material or equipment or material or equipment of other Suppliers may be submitted to Engineer for review under the circumstances described below.

1. "*Or-Equal*" Items: If in Engineer's sole discretion an item of material or equipment proposed by Contractor is functionally equal to that named and sufficiently similar so that no change in related Work will be required, it may be considered by Engineer as an "or-equal" item, in which case review and approval of the proposed item may, in Engineer's sole discretion, be accomplished without compliance with some or all of the requirements for approval of proposed substitute items. For the purposes of this Paragraph 6.05.A.1, a proposed item of material or equipment will be considered functionally equal to an item so named if:

a. in the exercise of reasonable judgment Engineer determines that:

- 1) it is at least equal in materials of construction, quality, durability, appearance, strength, and design characteristics;
- 2) it will reliably perform at least equally well the function and achieve the results imposed by the design concept of the completed Project as a functioning whole; and
- 3) it has a proven record of performance and availability of responsive service.

b. Contractor certifies that, if approved and incorporated into the Work:

- 1) there will be no increase in cost to the Owner or increase in Contract Times; and

2) it will conform substantially to the detailed requirements of the item named in the Contract Documents.

*2. Substitute Items:*

- a. If in Engineer's sole discretion an item of material or equipment proposed by Contractor does not qualify as an "or-equal" item under Paragraph 6.05.A.1, it will be considered a proposed substitute item.
- b. Contractor shall submit sufficient information as provided below to allow Engineer to determine if the item of material or equipment proposed is essentially equivalent to that named and an acceptable substitute therefor. Requests for review of proposed substitute items of material or equipment will not be accepted by Engineer from anyone other than Contractor.
- c. The requirements for review by Engineer will be as set forth in Paragraph 6.05.A.2.d, as supplemented by the General Requirements, and as Engineer may decide is appropriate under the circumstances.
- d. Contractor shall make written application to Engineer for review of a proposed substitute item of material or equipment that Contractor seeks to furnish or use. The application:
  - 1) shall certify that the proposed substitute item will:
    - a) perform adequately the functions and achieve the results called for by the general design,
    - b) be similar in substance to that specified, and
    - c) be suited to the same use as that specified;
  - 2) will state:
    - a) the extent, if any, to which the use of the proposed substitute item will prejudice Contractor's achievement of Substantial Completion on time,
    - b) whether use of the proposed substitute item in the Work will require a change in any of the Contract Documents (or in the provisions of any other direct contract with Owner for other work on the Project) to adapt the design to the proposed substitute item, and
    - c) whether incorporation or use of the proposed substitute item in connection with the Work is subject to payment of any license fee or royalty;
  - 3) will identify:
    - a) all variations of the proposed substitute item from that specified, and

- b) available engineering, sales, maintenance, repair, and replacement services; and
  - 4) shall contain an itemized estimate of all costs or credits that will result directly or indirectly from use of such substitute item, including costs of redesign and claims of other contractors affected by any resulting change.
- C. *Substitute Construction Methods or Procedures*: If a specific means, method, technique, sequence, or procedure of construction is expressly required by the Contract Documents, Contractor may furnish or utilize a substitute means, method, technique, sequence, or procedure of construction approved by Engineer. Contractor shall submit sufficient information to allow Engineer, in Engineer's sole discretion, to determine that the substitute proposed is equivalent to that expressly called for by the Contract Documents. The requirements for review by Engineer will be similar to those provided in Paragraph 6.05.A.2.
- D. *Engineer's Evaluation*: Engineer will be allowed a reasonable time within which to evaluate each proposal or submittal made pursuant to Paragraphs 6.05.A and 6.05.B. Engineer may require Contractor to furnish additional data about the proposed substitute item. Engineer will be the sole judge of acceptability. No "or equal" or substitute will be ordered, installed or utilized until Engineer's review is complete, which will be evidenced by a Change Order in the case of a substitute and an approved Shop Drawing for an "or equal." Engineer will advise Contractor in writing of any negative determination.
- E. *Special Guarantee*: Owner may require Contractor to furnish at Contractor's expense a special performance guarantee or other surety with respect to any substitute.
- F. *Engineer's Cost Reimbursement*: Engineer will record Engineer's costs in evaluating a substitute proposed or submitted by Contractor pursuant to Paragraphs 6.05.A.2 and 6.05.B. Whether or not Engineer approves a substitute so proposed or submitted by Contractor, Contractor shall reimburse Owner for the reasonable charges of Engineer for evaluating each such proposed substitute. Contractor shall also reimburse Owner for the reasonable charges of Engineer for making changes in the Contract Documents (or in the provisions of any other direct contract with Owner) resulting from the acceptance of each proposed substitute.
- G. *Contractor's Expense*: Contractor shall provide all data in support of any proposed substitute or "or-equal" at Contractor's expense.

## 6.6 Concerning Subcontractors, Suppliers, and Others

- A. Contractor shall not employ any Subcontractor, Supplier, or other individual or entity (including those acceptable to Owner as indicated in Paragraph 6.06.B), whether initially or as a replacement, against whom Owner may have reasonable objection. Contractor shall not be required to employ any Subcontractor, Supplier, or other individual or entity to furnish or perform any of the Work against whom Contractor has reasonable objection.
- B. If the Supplementary Conditions require the identity of certain Subcontractors, Suppliers, or other individuals or entities to be submitted to Owner in advance for acceptance by

Owner by a specified date prior to the Effective Date of the Agreement, and if Contractor has submitted a list thereof in accordance with the Supplementary Conditions, Owner's acceptance (either in writing or by failing to make written objection thereto by the date indicated for acceptance or objection in the Bidding Documents or the Contract Documents) of any such Subcontractor, Supplier, or other individual or entity so identified may be revoked on the basis of reasonable objection after due investigation. Contractor shall submit an acceptable replacement for the rejected Subcontractor, Supplier, or other individual or entity, and the Contract Price will be adjusted by the difference in the cost occasioned by such replacement, and an appropriate Change Order will be issued. No acceptance by Owner of any such Subcontractor, Supplier, or other individual or entity, whether initially or as a replacement, shall constitute a waiver of any right of Owner or Engineer to reject defective Work.

- C. Contractor shall be fully responsible to Owner and Engineer for all acts and omissions of the Subcontractors, Suppliers, and other individuals or entities performing or furnishing any of the Work just as Contractor is responsible for Contractor's own acts and omissions. Nothing in the Contract Documents:
1. shall create for the benefit of any such Subcontractor, Supplier, or other individual or entity any contractual relationship between Owner or Engineer and any such Subcontractor, Supplier or other individual or entity; nor
  2. shall create any obligation on the part of Owner or Engineer to pay or to see to the payment of any moneys due any such Subcontractor, Supplier, or other individual or entity except as may otherwise be required by Laws and Regulations.
- D. Contractor shall be solely responsible for scheduling and coordinating the Work of Subcontractors, Suppliers, and other individuals or entities performing or furnishing any of the Work under a direct or indirect contract with Contractor.
- E. Contractor shall require all Subcontractors, Suppliers, and such other individuals or entities performing or furnishing any of the Work to communicate with Engineer through Contractor.
- F. The divisions and sections of the Specifications and the identifications of any Drawings shall not control Contractor in dividing the Work among Subcontractors or Suppliers or delineating the Work to be performed by any specific trade.
- G. All Work performed for Contractor by a Subcontractor or Supplier will be pursuant to an appropriate agreement between Contractor and the Subcontractor or Supplier which specifically binds the Subcontractor or Supplier to the applicable terms and conditions of the Contract Documents for the benefit of Owner and Engineer. Whenever any such agreement is with a Subcontractor or Supplier who is listed as a loss payee on the property insurance provided in Paragraph 5.06, the agreement between the Contractor and the Subcontractor or Supplier will contain provisions whereby the Subcontractor or Supplier waives all rights against Owner, Contractor, Engineer, and all other individuals or entities identified in the Supplementary Conditions to be listed as insureds or loss payees (and the officers, directors, members, partners, employees, agents, consultants, and subcontractors of each and any of them) for all losses and damages caused by, arising

out of, relating to, or resulting from any of the perils or causes of loss covered by such policies and any other property insurance applicable to the Work. If the insurers on any such policies require separate waiver forms to be signed by any Subcontractor or Supplier, Contractor will obtain the same.

#### *6.7 Patent Fees and Royalties*

- A. Contractor shall pay all license fees and royalties and assume all costs incident to the use in the performance of the Work or the incorporation in the Work of any invention, design, process, product, or device which is the subject of patent rights or copyrights held by others. If a particular invention, design, process, product, or device is specified in the Contract Documents for use in the performance of the Work and if, to the actual knowledge of Owner or Engineer, its use is subject to patent rights or copyrights calling for the payment of any license fee or royalty to others, the existence of such rights shall be disclosed by Owner in the Contract Documents.
- B. To the fullest extent permitted by Laws and Regulations, Owner shall indemnify and hold harmless Contractor, and its officers, directors, members, partners, employees, agents, consultants, and subcontractors from and against all claims, costs, losses, and damages (including but not limited to all fees and charges of engineers, architects, attorneys, and other professionals, and all court or arbitration or other dispute resolution costs) arising out of or relating to any infringement of patent rights or copyrights incident to the use in the performance of the Work or resulting from the incorporation in the Work of any invention, design, process, product, or device specified in the Contract Documents, but not identified as being subject to payment of any license fee or royalty to others required by patent rights or copyrights.
- C. To the fullest extent permitted by Laws and Regulations, Contractor shall indemnify and hold harmless Owner and Engineer, and the officers, directors, members, partners, employees, agents, consultants and subcontractors of each and any of them from and against all claims, costs, losses, and damages (including but not limited to all fees and charges of engineers, architects, attorneys, and other professionals and all court or arbitration or other dispute resolution costs) arising out of or relating to any infringement of patent rights or copyrights incident to the use in the performance of the Work or resulting from the incorporation in the Work of any invention, design, process, product, or device not specified in the Contract Documents.

#### *6.8 Permits*

- A. Unless otherwise provided in the Supplementary Conditions, Contractor shall obtain and pay for all construction permits and licenses. Owner shall assist Contractor, when necessary, in obtaining such permits and licenses. Contractor shall pay all governmental charges and inspection fees necessary for the prosecution of the Work which are applicable at the time of opening of Bids, or, if there are no Bids, on the Effective Date of the Agreement. Owner shall pay all charges of utility owners for connections for providing permanent service to the Work.

#### *6.9 Laws and Regulations*

- A. Contractor shall give all notices required by and shall comply with all Laws and Regulations applicable to the performance of the Work. Except where otherwise expressly required by applicable Laws and Regulations, neither Owner nor Engineer shall be responsible for monitoring Contractor's compliance with any Laws or Regulations.
- B. If Contractor performs any Work knowing or having reason to know that it is contrary to Laws or Regulations, Contractor shall bear all claims, costs, losses, and damages (including but not limited to all fees and charges of engineers, architects, attorneys, and other professionals and all court or arbitration or other dispute resolution costs) arising out of or relating to such Work. However, it shall not be Contractor's responsibility to make certain that the Specifications and Drawings are in accordance with Laws and Regulations, but this shall not relieve Contractor of Contractor's obligations under Paragraph 3.03.
- C. Changes in Laws or Regulations not known at the time of opening of Bids (or, on the Effective Date of the Agreement if there were no Bids) having an effect on the cost or time of performance of the Work shall be the subject of an adjustment in Contract Price or Contract Times. If Owner and Contractor are unable to agree on entitlement to or on the amount or extent, if any, of any such adjustment, a Claim may be made therefor as provided in Paragraph 10.05.

#### *6.10 Taxes*

- A. Contractor shall pay all sales, consumer, use, and other similar taxes required to be paid by Contractor in accordance with the Laws and Regulations of the place of the Project which are applicable during the performance of the Work.

#### *6.11 Use of Site and Other Areas*

##### *A. Limitation on Use of Site and Other Areas:*

1. Contractor shall confine construction equipment, the storage of materials and equipment, and the operations of workers to the Site and other areas permitted by Laws and Regulations, and shall not unreasonably encumber the Site and other areas with construction equipment or other materials or equipment. Contractor shall assume full responsibility for any damage to any such land or area, or to the owner or occupant thereof, or of any adjacent land or areas resulting from the performance of the Work.
2. Should any claim be made by any such owner or occupant because of the performance of the Work, Contractor shall promptly settle with such other party by negotiation or otherwise resolve the claim by arbitration or other dispute resolution proceeding or at law.
3. To the fullest extent permitted by Laws and Regulations, Contractor shall indemnify and hold harmless Owner and Engineer, and the officers, directors, members, partners, employees, agents, consultants and subcontractors of each and any of them from and against all claims, costs, losses, and damages (including but not limited to all fees and charges of engineers, architects, attorneys, and other professionals and all

court or arbitration or other dispute resolution costs) arising out of or relating to any claim or action, legal or equitable, brought by any such owner or occupant against Owner, Engineer, or any other party indemnified hereunder to the extent caused by or based upon Contractor's performance of the Work.

- B. *Removal of Debris During Performance of the Work:* During the progress of the Work Contractor shall keep the Site and other areas free from accumulations of waste materials, rubbish, and other debris. Removal and disposal of such waste materials, rubbish, and other debris shall conform to applicable Laws and Regulations.
- C. *Cleaning:* Prior to Substantial Completion of the Work Contractor shall clean the Site and the Work and make it ready for utilization by Owner. At the completion of the Work Contractor shall remove from the Site all tools, appliances, construction equipment and machinery, and surplus materials and shall restore to original condition all property not designated for alteration by the Contract Documents.
- D. *Loading Structures:* Contractor shall not load nor permit any part of any structure to be loaded in any manner that will endanger the structure, nor shall Contractor subject any part of the Work or adjacent property to stresses or pressures that will endanger it.

#### *6.12 Record Documents*

- A. Contractor shall maintain in a safe place at the Site one record copy of all Drawings, Specifications, Addenda, Change Orders, Work Change Directives, Field Orders, and written interpretations and clarifications in good order and annotated to show changes made during construction. These record documents together with all approved Samples and a counterpart of all approved Shop Drawings will be available to Engineer for reference. Upon completion of the Work, these record documents, Samples, and Shop Drawings will be delivered to Engineer for Owner.

#### *6.13 Safety and Protection*

- A. Contractor shall be solely responsible for initiating, maintaining and supervising all safety precautions and programs in connection with the Work. Such responsibility does not relieve Subcontractors of their responsibility for the safety of persons or property in the performance of their work, nor for compliance with applicable safety Laws and Regulations. Contractor shall take all necessary precautions for the safety of, and shall provide the necessary protection to prevent damage, injury or loss to:
  - 1. all persons on the Site or who may be affected by the Work;
  - 2. all the Work and materials and equipment to be incorporated therein, whether in storage on or off the Site; and
  - 3. other property at the Site or adjacent thereto, including trees, shrubs, lawns, walks, pavements, roadways, structures, utilities, and Underground Facilities not designated for removal, relocation, or replacement in the course of construction.

- B. Contractor shall comply with all applicable Laws and Regulations relating to the safety of persons or property, or to the protection of persons or property from damage, injury, or loss; and shall erect and maintain all necessary safeguards for such safety and protection. Contractor shall notify owners of adjacent property and of Underground Facilities and other utility owners when prosecution of the Work may affect them, and shall cooperate with them in the protection, removal, relocation, and replacement of their property.
- C. Contractor shall comply with the applicable requirements of Owner's safety programs, if any. The Supplementary Conditions identify any Owner's safety programs that are applicable to the Work.
- D. Contractor shall inform Owner and Engineer of the specific requirements of Contractor's safety program with which Owner's and Engineer's employees and representatives must comply while at the Site.
- E. All damage, injury, or loss to any property referred to in Paragraph 6.13.A.2 or 6.13.A.3 caused, directly or indirectly, in whole or in part, by Contractor, any Subcontractor, Supplier, or any other individual or entity directly or indirectly employed by any of them to perform any of the Work, or anyone for whose acts any of them may be liable, shall be remedied by Contractor (except damage or loss attributable to the fault of Drawings or Specifications or to the acts or omissions of Owner or Engineer or anyone employed by any of them, or anyone for whose acts any of them may be liable, and not attributable, directly or indirectly, in whole or in part, to the fault or negligence of Contractor or any Subcontractor, Supplier, or other individual or entity directly or indirectly employed by any of them).
- F. Contractor's duties and responsibilities for safety and for protection of the Work shall continue until such time as all the Work is completed and Engineer has issued a notice to Owner and Contractor in accordance with Paragraph 14.07.B that the Work is acceptable (except as otherwise expressly provided in connection with Substantial Completion).

#### *6.14 Safety Representative*

- A. Contractor shall designate a qualified and experienced safety representative at the Site whose duties and responsibilities shall be the prevention of accidents and the maintaining and supervising of safety precautions and programs.

#### *6.15 Hazard Communication Programs*

- A. Contractor shall be responsible for coordinating any exchange of material safety data sheets or other hazard communication information required to be made available to or exchanged between or among employers at the Site in accordance with Laws or Regulations.

#### *6.16 Emergencies*

- A. In emergencies affecting the safety or protection of persons or the Work or property at the Site or adjacent thereto, Contractor is obligated to act to prevent threatened damage, injury, or loss. Contractor shall give Engineer prompt written notice if Contractor

believes that any significant changes in the Work or variations from the Contract Documents have been caused thereby or are required as a result thereof. If Engineer determines that a change in the Contract Documents is required because of the action taken by Contractor in response to such an emergency, a Work Change Directive or Change Order will be issued.

#### *6.17 Shop Drawings and Samples*

A. Contractor shall submit Shop Drawings and Samples to Engineer for review and approval in accordance with the accepted Schedule of Submittals (as required by Paragraph 2.07). Each submittal will be identified as Engineer may require.

##### *1. Shop Drawings:*

- a. Submit number of copies specified in the General Requirements.
- b. Data shown on the Shop Drawings will be complete with respect to quantities, dimensions, specified performance and design criteria, materials, and similar data to show Engineer the services, materials, and equipment Contractor proposes to provide and to enable Engineer to review the information for the limited purposes required by Paragraph 6.17.D.

##### *2. Samples:*

- a. Submit number of Samples specified in the Specifications.
- b. Clearly identify each Sample as to material, Supplier, pertinent data such as catalog numbers, the use for which intended and other data as Engineer may require to enable Engineer to review the submittal for the limited purposes required by Paragraph 6.17.D.

B. Where a Shop Drawing or Sample is required by the Contract Documents or the Schedule of Submittals, any related Work performed prior to Engineer's review and approval of the pertinent submittal will be at the sole expense and responsibility of Contractor.

##### *C. Submittal Procedures:*

1. Before submitting each Shop Drawing or Sample, Contractor shall have:

- a. reviewed and coordinated each Shop Drawing or Sample with other Shop Drawings and Samples and with the requirements of the Work and the Contract Documents;
- b. determined and verified all field measurements, quantities, dimensions, specified performance and design criteria, installation requirements, materials, catalog numbers, and similar information with respect thereto;

- c. determined and verified the suitability of all materials offered with respect to the indicated application, fabrication, shipping, handling, storage, assembly, and installation pertaining to the performance of the Work; and
  - d. determined and verified all information relative to Contractor's responsibilities for means, methods, techniques, sequences, and procedures of construction, and safety precautions and programs incident thereto.
  - e. All job specific details and options shall be marked, clearly noted, and highlighted
2. Each submittal shall bear a stamp or specific written certification that Contractor has satisfied Contractor's obligations under the Contract Documents with respect to Contractor's review and approval of that submittal.
  3. With each submittal, Contractor shall give Engineer specific written notice of any variations that the Shop Drawing or Sample may have from the requirements of the Contract Documents. This notice shall be both a written communication separate from the Shop Drawings or Sample submittal; and, in addition, by a specific notation made on each Shop Drawing or Sample submitted to Engineer for review and approval of each such variation.

*D. Engineer's Review:*

1. Engineer will provide timely review of Shop Drawings and Samples in accordance with the Schedule of Submittals acceptable to Engineer. Engineer's review and approval will be only to determine if the items covered by the submittals will, after installation or incorporation in the Work, conform to the information given in the Contract Documents and be compatible with the design concept of the completed Project as a functioning whole as indicated by the Contract Documents. Shop drawing review shall be a minimum of 14 days.
2. Engineer's review and approval will not extend to means, methods, techniques, sequences, or procedures of construction (except where a particular means, method, technique, sequence, or procedure of construction is specifically and expressly called for by the Contract Documents) or to safety precautions or programs incident thereto. The review and approval of a separate item as such will not indicate approval of the assembly in which the item functions.
3. Engineer's review and approval shall not relieve Contractor from responsibility for any variation from the requirements of the Contract Documents unless Contractor has complied with the requirements of Paragraph 6.17.C.3 and Engineer has given written approval of each such variation by specific written notation thereof incorporated in or accompanying the Shop Drawing or Sample. Engineer's review and approval shall not relieve Contractor from responsibility for complying with the requirements of Paragraph 6.17.C.1.

*E. Resubmittal Procedures:*

1. Contractor shall make corrections required by Engineer and shall return the required number of corrected copies of Shop Drawings and submit, as required, new Samples for review and approval. Contractor shall direct specific attention in writing to revisions other than the corrections called for by Engineer on previous submittals

### *6.18 Continuing the Work*

- A. Contractor shall carry on the Work and adhere to the Progress Schedule during all disputes or disagreements with Owner. No Work shall be delayed or postponed pending resolution of any disputes or disagreements, except as permitted by Paragraph 15.04 or as Owner and Contractor may otherwise agree in writing.

### *6.19 Contractor's General Warranty and Guarantee*

- A. Contractor warrants and guarantees to Owner that all Work will be in accordance with the Contract Documents and will not be defective. Engineer and its officers, directors, members, partners, employees, agents, consultants, and subcontractors shall be entitled to rely on representation of Contractor's warranty and guarantee.
- B. Contractor's warranty and guarantee hereunder excludes defects or damage caused by:
  - 1. abuse, modification, or improper maintenance or operation by persons other than Contractor, Subcontractors, Suppliers, or any other individual or entity for whom Contractor is responsible; or
  - 2. normal wear and tear under normal usage.
- C. Contractor's obligation to perform and complete the Work in accordance with the Contract Documents shall be absolute. None of the following will constitute an acceptance of Work that is not in accordance with the Contract Documents or a release of Contractor's obligation to perform the Work in accordance with the Contract Documents:
  - 1. observations by Engineer;
  - 2. recommendation by Engineer or payment by Owner of any progress or final payment;
  - 3. the issuance of a certificate of Substantial Completion by Engineer or any payment related thereto by Owner;
  - 4. use or occupancy of the Work or any part thereof by Owner;
  - 5. any review and approval of a Shop Drawing or Sample submittal or the issuance of a notice of acceptability by Engineer;
  - 6. any inspection, test, or approval by others; or
  - 7. any correction of defective Work by Owner.

### *6.20 Indemnification*

- A. To the fullest extent permitted by Laws and Regulations, Contractor shall indemnify and hold harmless Owner and Engineer, and the officers, directors, members, partners, employees, agents, consultants and subcontractors of each and any of them from and

- against all claims, costs, losses, and damages (including but not limited to all fees and charges of engineers, architects, attorneys, and other professionals and all court or arbitration or other dispute resolution costs) arising out of or relating to the performance of the Work, provided that any such claim, cost, loss, or damage is attributable to bodily injury, sickness, disease, or death, or to injury to or destruction of tangible property (other than the Work itself), including the loss of use resulting therefrom but only to the extent caused by any negligent act or omission of Contractor, any Subcontractor, any Supplier, or any individual or entity directly or indirectly employed by any of them to perform any of the Work or anyone for whose acts any of them may be liable .
- B. In any and all claims against Owner or Engineer or any of their officers, directors, members, partners, employees, agents, consultants, or subcontractors by any employee (or the survivor or personal representative of such employee) of Contractor, any Subcontractor, any Supplier, or any individual or entity directly or indirectly employed by any of them to perform any of the Work, or anyone for whose acts any of them may be liable, the indemnification obligation under Paragraph 6.20.A shall not be limited in any way by any limitation on the amount or type of damages, compensation, or benefits payable by or for Contractor or any such Subcontractor, Supplier, or other individual or entity under workers' compensation acts, disability benefit acts, or other employee benefit acts.
- C. The indemnification obligations of Contractor under Paragraph 6.20.A shall not extend to the liability of Engineer and Engineer's officers, directors, members, partners, employees, agents, consultants and subcontractors arising out of:
1. the preparation or approval of, or the failure to prepare or approve maps, Drawings, opinions, reports, surveys, Change Orders, designs, or Specifications; or
  2. giving directions or instructions, or failing to give them, if that is the primary cause of the injury or damage.

#### *6.21 Delegation of Professional Design Services*

- A. Contractor will not be required to provide professional design services unless such services are specifically required by the Contract Documents for a portion of the Work or unless such services are required to carry out Contractor's responsibilities for construction means, methods, techniques, sequences and procedures. Contractor shall not be required to provide professional services in violation of applicable law.
- B. If professional design services or certifications by a design professional related to systems, materials or equipment are specifically required of Contractor by the Contract Documents, Owner and Engineer will specify all performance and design criteria that such services must satisfy. Contractor shall cause such services or certifications to be provided by a properly licensed professional, whose signature and seal shall appear on all drawings, calculations, specifications, certifications, Shop Drawings and other submittals prepared by such professional. Shop Drawings and other submittals related to the Work designed or certified by such professional, if prepared by others, shall bear such professional's written approval when submitted to Engineer.

- C. Owner and Engineer shall be entitled to rely upon the adequacy, accuracy and completeness of the services, certifications or approvals performed by such design professionals, provided Owner and Engineer have specified to Contractor all performance and design criteria that such services must satisfy.
- D. Pursuant to this Paragraph 6.21, Engineer's review and approval of design calculations and design drawings will be only for the limited purpose of checking for conformance with performance and design criteria given and the design concept expressed in the Contract Documents. Engineer's review and approval of Shop Drawings and other submittals (except design calculations and design drawings) will be only for the purpose stated in Paragraph 6.17.D.1.
- E. Contractor shall not be responsible for the adequacy of the performance or design criteria required by the Contract Documents.

## **ARTICLE 7 – OTHER WORK AT THE SITE**

### *7.1 Related Work at Site*

- A. Owner may perform other work related to the Project at the Site with Owner's employees, or through other direct contracts therefor, or have other work performed by utility owners. If such other work is not noted in the Contract Documents, then:
  - 1. written notice thereof will be given to Contractor prior to starting any such other work; and
  - 2. if Owner and Contractor are unable to agree on entitlement to or on the amount or extent, if any, of any adjustment in the Contract Price or Contract Times that should be allowed as a result of such other work, a Claim may be made therefor as provided in Paragraph 10.05.
- B. Contractor shall afford each other contractor who is a party to such a direct contract, each utility owner, and Owner, if Owner is performing other work with Owner's employees, proper and safe access to the Site, provide a reasonable opportunity for the introduction and storage of materials and equipment and the execution of such other work, and properly coordinate the Work with theirs. Contractor shall do all cutting, fitting, and patching of the Work that may be required to properly connect or otherwise make its several parts come together and properly integrate with such other work. Contractor shall not endanger any work of others by cutting, excavating, or otherwise altering such work; provided, however, that Contractor may cut or alter others' work with the written consent of Engineer and the others whose work will be affected. The duties and responsibilities of Contractor under this Paragraph are for the benefit of such utility owners and other contractors to the extent that there are comparable provisions for the benefit of Contractor in said direct contracts between Owner and such utility owners and other contractors.
- C. If the proper execution or results of any part of Contractor's Work depends upon work performed by others under this Article 7, Contractor shall inspect such other work and promptly report to Engineer in writing any delays, defects, or deficiencies in such other work that render it unavailable or unsuitable for the proper execution and results of

Contractor's Work. Contractor's failure to so report will constitute an acceptance of such other work as fit and proper for integration with Contractor's Work except for latent defects and deficiencies in such other work.

## 7.2 *Coordination*

- A. If Owner intends to contract with others for the performance of other work on the Project at the Site, the following will be set forth in Supplementary Conditions:
  - 1. the individual or entity who will have authority and responsibility for coordination of the activities among the various contractors will be identified;
  - 2. the specific matters to be covered by such authority and responsibility will be itemized; and
  - 3. the extent of such authority and responsibilities will be provided.
- B. Unless otherwise provided in the Supplementary Conditions, Owner shall have sole authority and responsibility for such coordination.

## 7.3 *Legal Relationships*

- A. Paragraphs 7.01.A and 7.02 are not applicable for utilities not under the control of Owner.
- B. Each other direct contract of Owner under Paragraph 7.01.A shall provide that the other contractor is liable to Owner and Contractor for the reasonable direct delay and disruption costs incurred by Contractor as a result of the other contractor's wrongful actions or inactions.
- C. Contractor shall be liable to Owner and any other contractor under direct contract to Owner for the reasonable direct delay and disruption costs incurred by such other contractor as a result of Contractor's wrongful action or inactions.

# **ARTICLE 8 – OWNER'S RESPONSIBILITIES**

## 8.1 *Communications to Contractor*

- A. Except as otherwise provided in these General Conditions, Owner shall issue all communications to Contractor through Engineer.

## 8.2 *Replacement of Engineer*

- A. In case of termination of the employment of Engineer, Owner shall appoint an engineer to whom Contractor makes no reasonable objection, whose status under the Contract Documents shall be that of the former Engineer.

## 8.3 *Furnish Data*

- A. Owner shall promptly furnish the data required of Owner under the Contract Documents.

#### *8.4 Pay When Due*

- A. Owner shall make payments to Contractor when they are due as provided in Paragraphs 14.02.C and 14.07.C.

#### *8.5 Lands and Easements; Reports and Tests*

- A. Owner's duties with respect to providing lands and easements and providing engineering surveys to establish reference points are set forth in Paragraphs 4.01 and 4.05. Paragraph 4.02 refers to Owner's identifying and making available to Contractor copies of reports of explorations and tests of subsurface conditions and drawings of physical conditions relating to existing surface or subsurface structures at the Site.

#### *8.6 Insurance*

- A. Owner's responsibilities, if any, with respect to purchasing and maintaining liability and property insurance are set forth in Article 5.

#### *8.7 Change Orders*

- A. Owner is obligated to execute Change Orders as indicated in Paragraph 10.03.

#### *8.8 Inspections, Tests, and Approvals*

- A. Owner's responsibility with respect to certain inspections, tests, and approvals is set forth in Paragraph 13.03.B.

#### *8.9 Limitations on Owner's Responsibilities*

- A. The Owner shall not supervise, direct, or have control or authority over, nor be responsible for, Contractor's means, methods, techniques, sequences, or procedures of construction, or the safety precautions and programs incident thereto, or for any failure of Contractor to comply with Laws and Regulations applicable to the performance of the Work. Owner will not be responsible for Contractor's failure to perform the Work in accordance with the Contract Documents.

#### *8.10 Undisclosed Hazardous Environmental Condition*

- A. Owner's responsibility in respect to an undisclosed Hazardous Environmental Condition is set forth in Paragraph 4.06.

#### *8.11 Evidence of Financial Arrangements*

- A. Upon request of Contractor, Owner shall furnish Contractor reasonable evidence that financial arrangements have been made to satisfy Owner's obligations under the Contract Documents.

#### *8.12 Compliance with Safety Program*

- A. While at the Site, Owner's employees and representatives shall comply with the specific applicable requirements of Contractor's safety programs of which Owner has been informed pursuant to Paragraph 6.13.D.

## **ARTICLE 9 – ENGINEER'S STATUS DURING CONSTRUCTION**

### *9.1 Owner's Representative*

- A. Engineer will be Owner's representative during the construction period. The duties and responsibilities and the limitations of authority of Engineer as Owner's representative during construction are set forth in the Contract Documents.

### *9.2 Visits to Site*

- A. Engineer will make visits to the Site at intervals appropriate to the various stages of construction as Engineer deems necessary in order to observe as an experienced and qualified design professional the progress that has been made and the quality of the various aspects of Contractor's executed Work. Based on information obtained during such visits and observations, Engineer, for the benefit of Owner, will determine, in general, if the Work is proceeding in accordance with the Contract Documents. Engineer will not be required to make exhaustive or continuous inspections on the Site to check the quality or quantity of the Work. Engineer's efforts will be directed toward providing for Owner a greater degree of confidence that the completed Work will conform generally to the Contract Documents. On the basis of such visits and observations, Engineer will keep Owner informed of the progress of the Work and will endeavor to guard Owner against defective Work.
- B. Engineer's visits and observations are subject to all the limitations on Engineer's authority and responsibility set forth in Paragraph 9.09. Particularly, but without limitation, during or as a result of Engineer's visits or observations of Contractor's Work, Engineer will not supervise, direct, control, or have authority over or be responsible for Contractor's means, methods, techniques, sequences, or procedures of construction, or the safety precautions and programs incident thereto, or for any failure of Contractor to comply with Laws and Regulations applicable to the performance of the Work.

### *9.3 Authorized Variations in Work*

- A. Engineer may authorize minor variations in the Work from the requirements of the Contract Documents which do not involve an adjustment in the Contract Price or the Contract Times and are compatible with the design concept of the completed Project as a functioning whole as indicated by the Contract Documents. These may be accomplished by a Field Order and will be binding on Owner and also on Contractor, who shall perform the Work involved promptly. If Owner or Contractor believes that a Field Order justifies an adjustment in the Contract Price or Contract Times, or both, and the parties are unable to agree on entitlement to or on the amount or extent, if any, of any such adjustment, a Claim may be made therefor as provided in Paragraph 10.05.

### *9.4 Rejecting Defective Work*

- A. Engineer will have authority to reject Work which Engineer believes to be defective, or that Engineer believes will not produce a completed Project that conforms to the Contract Documents or that will prejudice the integrity of the design concept of the completed Project as a functioning whole as indicated by the Contract Documents. Engineer will also have authority to require special inspection or testing of the Work as provided in Paragraph 13.04, whether or not the Work is fabricated, installed, or completed.

#### *9.5 Shop Drawings, Change Orders and Payments*

- A. In connection with Engineer's authority, and limitations thereof, as to Shop Drawings and Samples, see Paragraph 6.17.
- B. In connection with Engineer's authority, and limitations thereof, as to design calculations and design drawings submitted in response to a delegation of professional design services, if any, see Paragraph 6.21.
- C. In connection with Engineer's authority as to Change Orders, see Articles 10, 11, and 12.
- D. In connection with Engineer's authority as to Applications for Payment, see Article 14.

#### *9.6 Decisions on Requirements of Contract Documents and Acceptability of Work*

- A. Engineer will be the initial interpreter of the requirements of the Contract Documents and judge of the acceptability of the Work thereunder. All matters in question and other matters between Owner and Contractor arising prior to the date final payment is due relating to the acceptability of the Work, and the interpretation of the requirements of the Contract Documents pertaining to the performance of the Work, will be referred initially to Engineer in writing within 30 days of the event giving rise to the question.
- B. Engineer will, with reasonable promptness, render a written decision on the issue referred. If Owner or Contractor believes that any such decision entitles them to an adjustment in the Contract Price or Contract Times or both, a Claim may be made under Paragraph 10.05. The date of Engineer's decision shall be the date of the event giving rise to the issues referenced for the purposes of Paragraph 10.05.B.
- C. Engineer's written decision on the issue referred will be final and binding on Owner and Contractor, subject to the provisions of Paragraph 10.05.
- D. When functioning as interpreter and judge under this Paragraph 9.08, Engineer will not show partiality to Owner or Contractor and will not be liable in connection with any interpretation or decision rendered in good faith in such capacity.

#### *9.7 Limitations on Engineer's Authority and Responsibilities*

- A. Neither Engineer's authority or responsibility under this Article 9 or under any other provision of the Contract Documents nor any decision made by Engineer in good faith either to exercise or not exercise such authority or responsibility or the undertaking, exercise, or performance of any authority or responsibility by Engineer shall create, impose, or give rise to any duty in contract, tort, or otherwise owed by Engineer to

Contractor, any Subcontractor, any Supplier, any other individual or entity, or to any surety for or employee or agent of any of them.

- B. Engineer will not supervise, direct, control, or have authority over or be responsible for Contractor's means, methods, techniques, sequences, or procedures of construction, or the safety precautions and programs incident thereto, or for any failure of Contractor to comply with Laws and Regulations applicable to the performance of the Work. Engineer will not be responsible for Contractor's failure to perform the Work in accordance with the Contract Documents.
- C. Engineer will not be responsible for the acts or omissions of Contractor or of any Subcontractor, any Supplier, or of any other individual or entity performing any of the Work.
- D. Engineer's review of the final Application for Payment and accompanying documentation and all maintenance and operating instructions, schedules, guarantees, bonds, certificates of inspection, tests and approvals, and other documentation required to be delivered by Paragraph 14.07.A will only be to determine generally that their content complies with the requirements of, and in the case of certificates of inspections, tests, and approvals that the results certified indicate compliance with, the Contract Documents.
- E. The limitations upon authority and responsibility set forth in this Paragraph 9.09 shall also apply to the Resident Project Representative, if any, and assistants, if any.

#### *9.8 Compliance with Safety Program*

- A. While at the Site, Engineer's employees and representatives shall comply with the specific applicable requirements of Contractor's safety programs of which Engineer has been informed pursuant to Paragraph 6.13.D.

### **ARTICLE 10 – CHANGES IN THE WORK; CLAIMS**

#### *10.1 Authorized Changes in the Work*

- A. Without invalidating the Contract and without notice to any surety, Owner may, at any time or from time to time, order additions, deletions, or revisions in the Work by a Change Order, or a Work Change Directive. Upon receipt of any such document, Contractor shall promptly proceed with the Work involved which will be performed under the applicable conditions of the Contract Documents (except as otherwise specifically provided).
- B. If Owner and Contractor are unable to agree on entitlement to, or on the amount or extent, if any, of an adjustment in the Contract Price or Contract Times, or both, that should be allowed as a result of a Work Change Directive, a Claim may be made therefor as provided in Paragraph 10.05.

#### *10.2 Unauthorized Changes in the Work*

- A. Contractor shall not be entitled to an increase in the Contract Price or an extension of the Contract Times with respect to any work performed that is not required by the Contract Documents as amended, modified, or supplemented as provided in Paragraph 3.04,

except in the case of an emergency as provided in Paragraph 6.16 or in the case of uncovering Work as provided in Paragraph 13.04.D.

### *10.3 Execution of Change Orders*

- A. Owner and Contractor shall execute appropriate Change Orders recommended by Engineer covering:
  - 1. changes in the Work which are: (i) ordered by Owner pursuant to Paragraph 10.01.A, (ii) required because of acceptance of defective Work under Paragraph 13.08.A or Owner's correction of defective Work under Paragraph 13.09, or (iii) agreed to by the parties;
  - 2. changes in the Contract Price or Contract Times which are agreed to by the parties, including any undisputed sum or amount of time for Work actually performed in accordance with a Work Change Directive; and
  - 3. changes in the Contract Price or Contract Times which embody the substance of any written decision rendered by Engineer pursuant to Paragraph 10.05; provided that, in lieu of executing any such Change Order, an appeal may be taken from any such decision in accordance with the provisions of the Contract Documents and applicable Laws and Regulations, but during any such appeal, Contractor shall carry on the Work and adhere to the Progress Schedule as provided in Paragraph 6.18.A.

### *10.4 Notification to Surety*

- A. If the provisions of any bond require notice to be given to a surety of any change affecting the general scope of the Work or the provisions of the Contract Documents (including, but not limited to, Contract Price or Contract Times), the giving of any such notice will be Contractor's responsibility. The amount of each applicable bond will be adjusted to reflect the effect of any such change.

### *10.5 Claims*

- A. *Engineer's Decision Required:* All Claims, except those waived pursuant to Paragraph 14.09, shall be referred to the Engineer for decision. A decision by Engineer shall be required as a condition precedent to any exercise by Owner or Contractor of any rights or remedies either may otherwise have under the Contract Documents or by Laws and Regulations in respect of such Claims.
- B. *Notice:* Written notice stating the general nature of each Claim shall be delivered by the claimant to Engineer and the other party to the Contract promptly (but in no event later than 30 days) after the start of the event giving rise thereto. The responsibility to substantiate a Claim shall rest with the party making the Claim. Notice of the amount or extent of the Claim, with supporting data shall be delivered to the Engineer and the other party to the Contract within 60 days after the start of such event (unless Engineer allows additional time for claimant to submit additional or more accurate data in support of such Claim). A Claim for an adjustment in Contract Price shall be prepared in accordance with the provisions of Paragraph 12.01.B. A Claim for an adjustment in Contract Times shall be prepared in accordance with the provisions of Paragraph 12.02.B. Each Claim shall be

accompanied by claimant's written statement that the adjustment claimed is the entire adjustment to which the claimant believes it is entitled as a result of said event. The opposing party shall submit any response to Engineer and the claimant within 30 days after receipt of the claimant's last submittal (unless Engineer allows additional time).

- C. *Engineer's Action:* Engineer will review each Claim and, within 30 days after receipt of the last submittal of the claimant or the last submittal of the opposing party, if any, take one of the following actions in writing:
1. deny the Claim in whole or in part;
  2. approve the Claim; or
  3. notify the parties that the Engineer is unable to resolve the Claim if, in the Engineer's sole discretion, it would be inappropriate for the Engineer to do so. For purposes of further resolution of the Claim, such notice shall be deemed a denial.
- D. In the event that Engineer does not take action on a Claim within said 30 days, the Claim shall be deemed denied.
- E. Engineer's written action under Paragraph 10.05.C or denial pursuant to Paragraphs 10.05.C.3 or 10.05.D will be final and binding upon Owner and Contractor, unless Owner or Contractor invoke the dispute resolution procedure set forth in Article 16 within 30 days of such action or denial.
- F. No Claim for an adjustment in Contract Price or Contract Times will be valid if not submitted in accordance with this Paragraph 10.05.

## **ARTICLE 11 – COST OF THE WORK; ALLOWANCES; UNIT PRICE WORK**

### *11.1 Cost of the Work*

- A. *Costs Included:* The term Cost of the Work means the sum of all costs, except those excluded in Paragraph 11.01.B, necessarily incurred and paid by Contractor in the proper performance of the Work. When the value of any Work covered by a Change Order or when a Claim for an adjustment in Contract Price is determined on the basis of Cost of the Work, the costs to be reimbursed to Contractor will be only those additional or incremental costs required because of the change in the Work or because of the event giving rise to the Claim. Except as otherwise may be agreed to in writing by Owner, such costs shall be in amounts no higher than those prevailing in the locality of the Project, shall not include any of the costs itemized in Paragraph 11.01.B, and shall include only the following items:
1. Payroll costs for employees in the direct employ of Contractor in the performance of the Work under schedules of job classifications agreed upon by Owner and Contractor. Such employees shall include, without limitation, superintendents, foremen, and other personnel employed full time on the Work. Payroll costs for employees not employed full time on the Work shall be apportioned on the basis of their time spent on the Work. Payroll costs shall include, but not be limited to, salaries and wages plus the cost of fringe benefits, which shall include social security contributions, unemployment, excise,

and payroll taxes, workers' compensation, health and retirement benefits, bonuses, sick leave, vacation and holiday pay applicable thereto. The expenses of performing Work outside of regular working hours, on Saturday, Sunday, or legal holidays, shall be included in the above to the extent authorized by Owner.

2. Cost of all materials and equipment furnished and incorporated in the Work, including costs of transportation and storage thereof, and Suppliers' field services required in connection therewith. All cash discounts shall accrue to Contractor unless Owner deposits funds with Contractor with which to make payments, in which case the cash discounts shall accrue to Owner. All trade discounts, rebates and refunds and returns from sale of surplus materials and equipment shall accrue to Owner, and Contractor shall make provisions so that they may be obtained.
3. Payments made by Contractor to Subcontractors for Work performed by Subcontractors. If required by Owner, Contractor shall obtain competitive bids from subcontractors acceptable to Owner and Contractor and shall deliver such bids to Owner, who will then determine, with the advice of Engineer, which bids, if any, will be acceptable. If any subcontract provides that the Subcontractor is to be paid on the basis of Cost of the Work plus a fee, the Subcontractor's Cost of the Work and fee shall be determined in the same manner as Contractor's Cost of the Work and fee as provided in this Paragraph 11.01.
4. Costs of special consultants (including but not limited to engineers, architects, testing laboratories, surveyors, attorneys, and accountants) employed for services specifically related to the Work.
5. Supplemental costs including the following:
  - a. The proportion of necessary transportation, travel, and subsistence expenses of Contractor's employees incurred in discharge of duties connected with the Work.
  - b. Cost, including transportation and maintenance, of all materials, supplies, equipment, machinery, appliances, office, and temporary facilities at the Site, and hand tools not owned by the workers, which are consumed in the performance of the Work, and cost, less market value, of such items used but not consumed which remain the property of Contractor.
  - c. Rentals of all construction equipment and machinery, and the parts thereof whether rented from Contractor or others in accordance with rental agreements approved by Owner with the advice of Engineer, and the costs of transportation, loading, unloading, assembly, dismantling, and removal thereof. All such costs shall be in accordance with the terms of said rental agreements. The rental of any such equipment, machinery, or parts shall cease when the use thereof is no longer necessary for the Work.
  - d. Sales, consumer, use, and other similar taxes related to the Work, and for which Contractor is liable, as imposed by Laws and Regulations.
  - e. Deposits lost for causes other than negligence of Contractor, any Subcontractor, or anyone directly or indirectly employed by any of them or for whose acts any of them may be liable, and royalty payments and fees for permits and licenses.
  - f. Losses and damages (and related expenses) caused by damage to the Work, not

compensated by insurance or otherwise, sustained by Contractor in connection with the performance of the Work (except losses and damages within the deductible amounts of property insurance established in accordance with Paragraph 5.06.D), provided such losses and damages have resulted from causes other than the negligence of Contractor, any Subcontractor, or anyone directly or indirectly employed by any of them or for whose acts any of them may be liable. Such losses shall include settlements made with the written consent and approval of Owner. No such losses, damages, and expenses shall be included in the Cost of the Work for the purpose of determining Contractor's fee.

- g. The cost of utilities, fuel, and sanitary facilities at the Site.
- h. Minor expenses such as telegrams, long distance telephone calls, telephone service at the Site, express and courier services, and similar petty cash items in connection with the Work.
- i. The costs of premiums for all bonds and insurance Contractor is required by the Contract Documents to purchase and maintain.

B. *Costs Excluded:* The term Cost of the Work shall not include any of the following items:

1. Payroll costs and other compensation of Contractor's officers, executives, principals (of partnerships and sole proprietorships), general managers, safety managers, engineers, architects, estimators, attorneys, auditors, accountants, purchasing and contracting agents, expeditors, timekeepers, clerks, and other personnel employed by Contractor, whether at the Site or in Contractor's principal or branch office for general administration of the Work and not specifically included in the agreed upon schedule of job classifications referred to in Paragraph 11.01.A.1 or specifically covered by Paragraph 11.01.A.4, all of which are to be considered administrative costs covered by the Contractor's fee.
2. Expenses of Contractor's principal and branch offices other than Contractor's office at the Site.
3. Any part of Contractor's capital expenses, including interest on Contractor's capital employed for the Work and charges against Contractor for delinquent payments.
4. Costs due to the negligence of Contractor, any Subcontractor, or anyone directly or indirectly employed by any of them or for whose acts any of them may be liable, including but not limited to, the correction of defective Work, disposal of materials or equipment wrongly supplied, and making good any damage to property.
5. Other overhead or general expense costs of any kind and the costs of any item not specifically and expressly included in Paragraphs 11.01.A.

C. *Contractor's Fee:* When all the Work is performed on the basis of cost-plus, Contractor's fee shall be determined as set forth in the Agreement. When the value of any Work covered by a Change Order or when a Claim for an adjustment in Contract Price is determined on the basis of Cost of the Work, Contractor's fee shall be determined as set forth in Paragraph 12.01.C.

D. *Documentation:* Whenever the Cost of the Work for any purpose is to be determined

pursuant to Paragraphs 11.01.A and 11.01.B, Contractor will establish and maintain records thereof in accordance with generally accepted accounting practices and submit in a form acceptable to Engineer an itemized cost breakdown together with supporting data.

### *11.2 Allowances*

A. It is understood that Contractor has included in the Contract Price all allowances so named in the Contract Documents and shall cause the Work so covered to be performed for such sums and by such persons or entities as may be acceptable to Owner and Engineer.

#### *B. Cash Allowances:*

1. Contractor agrees that:

- a. the cash allowances include the cost to Contractor (less any applicable trade discounts) of materials and equipment required by the allowances to be delivered at the Site, and all applicable taxes; and
- b. Contractor's costs for unloading and handling on the Site, labor, installation, overhead, profit, and other expenses contemplated for the cash allowances have been included in the Contract Price and not in the allowances, and no demand for additional payment on account of any of the foregoing will be valid.

#### *C. Contingency Allowance:*

1. Contractor agrees that a contingency allowance, if any, is for the sole use of Owner to cover unanticipated costs.

D. Prior to final payment, an appropriate Change Order will be issued as recommended by Engineer to reflect actual amounts due Contractor on account of Work covered by allowances, and the Contract Price shall be correspondingly adjusted.

### *11.3 Unit Price Work*

A. Where the Contract Documents provide that all or part of the Work is to be Unit Price Work, initially the Contract Price will be deemed to include for all Unit Price Work an amount equal to the sum of the unit price for each separately identified item of Unit Price Work times the estimated quantity of each item as indicated in the Agreement.

B. The estimated quantities of items of Unit Price Work are not guaranteed and are solely for the purpose of comparison of Bids and determining an initial Contract Price. Determinations of the actual quantities and classifications of Unit Price Work performed by Contractor will be made by Engineer subject to the provisions of Paragraph 9.07.

C. Each unit price will be deemed to include an amount considered by Contractor to be adequate to cover Contractor's overhead and profit for each separately identified item.

D. Owner or Contractor may make a Claim for an adjustment in the Contract Price in accordance with Paragraph 10.05 if:

1. the quantity of any item of Unit Price Work performed by Contractor differs materially and significantly from the estimated quantity of such item indicated in the Agreement; and
2. there is no corresponding adjustment with respect to any other item of Work; and
3. Contractor believes that Contractor is entitled to an increase in Contract Price as a result of having incurred additional expense or Owner believes that Owner is entitled to a decrease in Contract Price and the parties are unable to agree as to the amount of any such increase or decrease.

## **ARTICLE 12 – CHANGE OF CONTRACT PRICE; CHANGE OF CONTRACT TIMES**

### *12.1 Change of Contract Price*

- A. The Contract Price may only be changed by a Change Order. Any Claim for an adjustment in the Contract Price shall be based on written notice submitted by the party making the Claim to the Engineer and the other party to the Contract in accordance with the provisions of Paragraph 10.05.
- B. The value of any Work covered by a Change Order or of any Claim for an adjustment in the Contract Price will be determined as follows:
  1. where the Work involved is covered by unit prices contained in the Contract Documents, by application of such unit prices to the quantities of the items involved (subject to the provisions of Paragraph 11.03); or
  2. where the Work involved is not covered by unit prices contained in the Contract Documents, by a mutually agreed lump sum (which may include an allowance for overhead and profit not necessarily in accordance with Paragraph 12.01.C.2); or
  3. where the Work involved is not covered by unit prices contained in the Contract Documents and agreement to a lump sum is not reached under Paragraph 12.01.B.2, on the basis of the Cost of the Work (determined as provided in Paragraph 11.01) plus a Contractor's fee for overhead and profit (determined as provided in Paragraph 12.01.C).
- C. *Contractor's Fee:* The Contractor's fee for overhead and profit shall be determined as follows:
  1. a mutually acceptable fixed fee; or
  2. if a fixed fee is not agreed upon, then a fee based on the following percentages of the various portions of the Cost of the Work:
    - a. for costs incurred under Paragraphs 11.01.A.1 and 11.01.A.2, the Contractor's fee shall be 15 percent;
    - b. for costs incurred under Paragraph 11.01.A.3, the Contractor's fee shall be five

- percent;
- c. where one or more tiers of subcontracts are on the basis of Cost of the Work plus a fee and no fixed fee is agreed upon, the intent of Paragraphs 12.01.C.2.a and 12.01.C.2.b is that the Subcontractor who actually performs the Work, at whatever tier, will be paid a fee of 15 percent of the costs incurred by such Subcontractor under Paragraphs 11.01.A.1 and 11.01.A.2 and that any higher tier Subcontractor and Contractor will each be paid a fee of five percent of the amount paid to the next lower tier Subcontractor;
  - d. no fee shall be payable on the basis of costs itemized under Paragraphs 11.01.A.4, 11.01.A.5, and 11.01.B;
  - e. the amount of credit to be allowed by Contractor to Owner for any change which results in a net decrease in cost will be the amount of the actual net decrease in cost plus a deduction in Contractor's fee by an amount equal to five percent of such net decrease; and
  - f. when both additions and credits are involved in any one change, the adjustment in Contractor's fee shall be computed on the basis of the net change in accordance with Paragraphs 12.01.C.2.a through 12.01.C.2.e, inclusive.

## *12.2 Change of Contract Times*

- A. The Contract Times may only be changed by a Change Order. Any Claim for an adjustment in the Contract Times shall be based on written notice submitted by the party making the Claim to the Engineer and the other party to the Contract in accordance with the provisions of Paragraph 10.05.
- B. Any adjustment of the Contract Times covered by a Change Order or any Claim for an adjustment in the Contract Times will be determined in accordance with the provisions of this Article 12.

## *12.3 Delays*

- A. Where Contractor is prevented from completing any part of the Work within the Contract Times due to delay beyond the control of Contractor, the Contract Times will be extended in an amount equal to the time lost due to such delay if a Claim is made therefor as provided in Paragraph 12.02.A. Delays beyond the control of Contractor shall include, but not be limited to, acts or neglect by Owner, acts or neglect of utility owners or other contractors performing other work as contemplated by Article 7, fires, floods, epidemics, abnormal weather conditions, or acts of God.
- B. If Owner, Engineer, or other contractors or utility owners performing other work for Owner as contemplated by Article 7, or anyone for whom Owner is responsible, delays, disrupts, or interferes with the performance or progress of the Work, then Contractor shall be entitled to an equitable adjustment in the Contract Price or the Contract Times, or both. Contractor's entitlement to an adjustment of the Contract Times is conditioned on such adjustment being essential to Contractor's ability to complete the Work within the Contract Times.

- C. If Contractor is delayed in the performance or progress of the Work by fire, flood, epidemic, abnormal weather conditions, acts of God, acts or failures to act of utility owners not under the control of Owner, or other causes not the fault of and beyond control of Owner and Contractor, then Contractor shall be entitled to an equitable adjustment in Contract Times, if such adjustment is essential to Contractor's ability to complete the Work within the Contract Times. Such an adjustment shall be Contractor's sole and exclusive remedy for the delays described in this Paragraph 12.03.C.
- D. Owner, Engineer, and their officers, directors, members, partners, employees, agents, consultants, or subcontractors shall not be liable to Contractor for any claims, costs, losses, or damages (including but not limited to all fees and charges of engineers, architects, attorneys, and other professionals and all court or arbitration or other dispute resolution costs) sustained by Contractor on or in connection with any other project or anticipated project.
- E. Contractor shall not be entitled to an adjustment in Contract Price or Contract Times for delays within the control of Contractor. Delays attributable to and within the control of a Subcontractor or Supplier shall be deemed to be delays within the control of Contractor.

## **ARTICLE 13 – TESTS AND INSPECTIONS; CORRECTION, REMOVAL OR ACCEPTANCE OF DEFECTIVE WORK**

### *13.1 Notice of Defects*

- A. Prompt notice of all defective Work of which Owner or Engineer has actual knowledge will be given to Contractor. Defective Work may be rejected, corrected, or accepted as provided in this Article 13.

### *13.2 Access to Work*

- A. Owner, Engineer, their consultants and other representatives and personnel of Owner, independent testing laboratories, and governmental agencies with jurisdictional interests will have access to the Site and the Work at reasonable times for their observation, inspection, and testing. Contractor shall provide them proper and safe conditions for such access and advise them of Contractor's safety procedures and programs so that they may comply therewith as applicable.

### *13.3 Tests and Inspections*

- A. Contractor shall give Engineer timely notice of readiness of the Work for all required inspections, tests, or approvals and shall cooperate with inspection and testing personnel to facilitate required inspections or tests.
- B. Owner shall employ and pay for the services of an independent testing laboratory to perform all inspections, tests, or approvals required by the Contract Documents except:
  - 1. for inspections, tests, or approvals covered by Paragraphs 13.03.C and 13.03.D below;
  - 2. that costs incurred in connection with tests or inspections conducted pursuant to Paragraph 13.04.B shall be paid as provided in Paragraph 13.04.C; and
  - 3. as otherwise specifically provided in the Contract Documents.
- C. If Laws or Regulations of any public body having jurisdiction require any Work (or part thereof) specifically to be inspected, tested, or approved by an employee or other representative of such public body, Contractor shall assume full responsibility for arranging and obtaining such inspections, tests, or approvals, pay all costs in connection therewith, and furnish Engineer the required certificates of inspection or approval.
- D. Contractor shall be responsible for arranging and obtaining and shall pay all costs in connection with any inspections, tests, or approvals required for Owner's and Engineer's acceptance of materials or equipment to be incorporated in the Work; or acceptance of materials, mix designs, or equipment submitted for approval prior to Contractor's purchase thereof for incorporation in the Work. Such inspections, tests, or approvals shall be performed by organizations acceptable to Owner and Engineer.
- E. If any Work (or the work of others) that is to be inspected, tested, or approved is covered by Contractor without written concurrence of Engineer, Contractor shall, if requested by Engineer, uncover such Work for observation.
- F. Uncovering Work as provided in Paragraph 13.03.E shall be at Contractor's expense unless Contractor has given Engineer timely notice of Contractor's intention to cover the same and Engineer has not acted with reasonable promptness in response to such notice.

#### *13.4 Uncovering Work*

- A. If any Work is covered contrary to the written request of Engineer, it must, if requested by Engineer, be uncovered for Engineer's observation and replaced at Contractor's expense.
- B. If Engineer considers it necessary or advisable that covered Work be observed by Engineer or inspected or tested by others, Contractor, at Engineer's request, shall uncover, expose, or otherwise make available for observation, inspection, or testing as Engineer may require, that portion of the Work in question, furnishing all necessary labor, material, and equipment.
- C. If it is found that the uncovered Work is defective, Contractor shall pay all claims, costs, losses, and damages (including but not limited to all fees and charges of engineers, architects, attorneys, and other professionals and all court or arbitration or other dispute resolution costs) arising out of or relating to such uncovering, exposure, observation,

inspection, and testing, and of satisfactory replacement or reconstruction (including but not limited to all costs of repair or replacement of work of others); and Owner shall be entitled to an appropriate decrease in the Contract Price. If the parties are unable to agree as to the amount thereof, Owner may make a Claim therefor as provided in Paragraph 10.05.

- D. If the uncovered Work is not found to be defective, Contractor shall be allowed an increase in the Contract Price or an extension of the Contract Times, or both, directly attributable to such uncovering, exposure, observation, inspection, testing, replacement, and reconstruction. If the parties are unable to agree as to the amount or extent thereof, Contractor may make a Claim therefor as provided in Paragraph 10.05.

### *13.5 Owner May Stop the Work*

- A. If the Work is defective, or Contractor fails to supply sufficient skilled workers or suitable materials or equipment, or fails to perform the Work in such a way that the completed Work will conform to the Contract Documents, Owner may order Contractor to stop the Work, or any portion thereof, until the cause for such order has been eliminated; however, this right of Owner to stop the Work shall not give rise to any duty on the part of Owner to exercise this right for the benefit of Contractor, any Subcontractor, any Supplier, any other individual or entity, or any surety for, or employee or agent of any of them.

### *13.6 Correction or Removal of Defective Work*

- A. Promptly after receipt of written notice, Contractor shall correct all defective Work, whether or not fabricated, installed, or completed, or, if the Work has been rejected by Engineer, remove it from the Project and replace it with Work that is not defective. Contractor shall pay all claims, costs, losses, and damages (including but not limited to all fees and charges of engineers, architects, attorneys, and other professionals and all court or arbitration or other dispute resolution costs) arising out of or relating to such correction or removal (including but not limited to all costs of repair or replacement of work of others).
- B. When correcting defective Work under the terms of this Paragraph 13.06 or Paragraph 13.07, Contractor shall take no action that would void or otherwise impair Owner's special warranty and guarantee, if any, on said Work.

### *13.7 Correction Period*

- A. If within one year after the date of Substantial Completion (or such longer period of time as may be prescribed by the terms of any applicable special guarantee required by the Contract Documents) or by any specific provision of the Contract Documents, any Work is found to be defective, or if the repair of any damages to the land or areas made available for Contractor's use by Owner or permitted by Laws and Regulations as contemplated in Paragraph 6.11.A is found to be defective, Contractor shall promptly, without cost to Owner and in accordance with Owner's written instructions:
1. repair such defective land or areas; or
  2. correct such defective Work; or

3. if the defective Work has been rejected by Owner, remove it from the Project and replace it with Work that is not defective, and
  4. satisfactorily correct or repair or remove and replace any damage to other Work, to the work of others or other land or areas resulting therefrom.
- B. If Contractor does not promptly comply with the terms of Owner's written instructions, or in an emergency where delay would cause serious risk of loss or damage, Owner may have the defective Work corrected or repaired or may have the rejected Work removed and replaced. All claims, costs, losses, and damages (including but not limited to all fees and charges of engineers, architects, attorneys, and other professionals and all court or arbitration or other dispute resolution costs) arising out of or relating to such correction or repair or such removal and replacement (including but not limited to all costs of repair or replacement of work of others) will be paid by Contractor.
- C. In special circumstances where a particular item of equipment is placed in continuous service before Substantial Completion of all the Work, the correction period for that item may start to run from an earlier date if so provided in the Specifications.
- D. Where defective Work (and damage to other Work resulting therefrom) has been corrected or removed and replaced under this Paragraph 13.07, the correction period hereunder with respect to such Work will be extended for an additional period of one year after such correction or removal and replacement has been satisfactorily completed.
- E. Contractor's obligations under this Paragraph 13.07 are in addition to any other obligation or warranty. The provisions of this Paragraph 13.07 shall not be construed as a substitute for, or a waiver of, the provisions of any applicable statute of limitation or repose.

### *13.8 Acceptance of Defective Work*

- A. If, instead of requiring correction or removal and replacement of defective Work, Owner (and, prior to Engineer's recommendation of final payment, Engineer) prefers to accept it, Owner may do so. Contractor shall pay all claims, costs, losses, and damages (including but not limited to all fees and charges of engineers, architects, attorneys, and other professionals and all court or arbitration or other dispute resolution costs) attributable to Owner's evaluation of and determination to accept such defective Work (such costs to be approved by Engineer as to reasonableness) and for the diminished value of the Work to the extent not otherwise paid by Contractor pursuant to this sentence. If any such acceptance occurs prior to Engineer's recommendation of final payment, a Change Order will be issued incorporating the necessary revisions in the Contract Documents with respect to the Work, and Owner shall be entitled to an appropriate decrease in the Contract Price, reflecting the diminished value of Work so accepted. If the parties are unable to agree as to the amount thereof, Owner may make a Claim therefor as provided in Paragraph 10.05. If the acceptance occurs after such recommendation, an appropriate amount will be paid by Contractor to Owner.

### *13.9 Owner May Correct Defective Work*

- A. If Contractor fails within a reasonable time after written notice from Engineer to correct defective Work, or to remove and replace rejected Work as required by Engineer in

accordance with Paragraph 13.06.A, or if Contractor fails to perform the Work in accordance with the Contract Documents, or if Contractor fails to comply with any other provision of the Contract Documents, Owner may, after seven days written notice to Contractor, correct, or remedy any such deficiency.

- B. In exercising the rights and remedies under this Paragraph 13.09, Owner shall proceed expeditiously. In connection with such corrective or remedial action, Owner may exclude Contractor from all or part of the Site, take possession of all or part of the Work and suspend Contractor's services related thereto, take possession of Contractor's tools, appliances, construction equipment and machinery at the Site, and incorporate in the Work all materials and equipment stored at the Site or for which Owner has paid Contractor but which are stored elsewhere. Contractor shall allow Owner, Owner's representatives, agents and employees, Owner's other contractors, and Engineer and Engineer's consultants access to the Site to enable Owner to exercise the rights and remedies under this Paragraph.
- C. All claims, costs, losses, and damages (including but not limited to all fees and charges of engineers, architects, attorneys, and other professionals and all court or arbitration or other dispute resolution costs) incurred or sustained by Owner in exercising the rights and remedies under this Paragraph 13.09 will be charged against Contractor, and a Change Order will be issued incorporating the necessary revisions in the Contract Documents with respect to the Work; and Owner shall be entitled to an appropriate decrease in the Contract Price. If the parties are unable to agree as to the amount of the adjustment, Owner may make a Claim therefor as provided in Paragraph 10.05. Such claims, costs, losses and damages will include but not be limited to all costs of repair, or replacement of work of others destroyed or damaged by correction, removal, or replacement of Contractor's defective Work.
- D. Contractor shall not be allowed an extension of the Contract Times because of any delay in the performance of the Work attributable to the exercise by Owner of Owner's rights and remedies under this Paragraph 13.09.

## **ARTICLE 14 – PAYMENTS TO CONTRACTOR AND COMPLETION**

### *14.1 Schedule of Values*

- A. The Schedule of Values established as provided in Paragraph 2.07.A will serve as the basis for progress payments and will be incorporated into a form of Application for Payment acceptable to Engineer. Progress payments on account of Unit Price Work will be based on the number of units completed.

### *14.2 Progress Payments*

#### *A. Applications for Payments:*

1. At least 20 days before the date established in the Agreement for each progress payment (but not more often than once a month), Contractor shall submit to Engineer for review an Application for Payment filled out and signed by Contractor covering the Work completed as of the date of the Application and accompanied by such supporting documentation as is required by the Contract Documents. If payment is requested on the basis of materials and equipment not incorporated in the Work but delivered and

suitably stored at the Site or at another location agreed to in writing, the Application for Payment shall also be accompanied by a bill of sale, invoice, or other documentation warranting that Owner has received the materials and equipment free and clear of all Liens and evidence that the materials and equipment are covered by appropriate property insurance or other arrangements to protect Owner's interest therein, all of which must be satisfactory to Owner.

2. Beginning with the second Application for Payment, each Application shall include an affidavit of Contractor stating that all previous progress payments received on account of the Work have been applied on account to discharge Contractor's legitimate obligations associated with prior Applications for Payment.
3. The amount of retainage with respect to progress payments will be as stipulated in the Agreement.

*B. Review of Applications:*

1. Engineer will, within 10 days after receipt of each Application for Payment, either indicate in writing a recommendation of payment and present the Application to Owner or return the Application to Contractor indicating in writing Engineer's reasons for refusing to recommend payment. In the latter case, Contractor may make the necessary corrections and resubmit the Application.
2. Engineer's recommendation of any payment requested in an Application for Payment will constitute a representation by Engineer to Owner, based on Engineer's observations of the executed Work as an experienced and qualified design professional, and on Engineer's review of the Application for Payment and the accompanying data and schedules, that to the best of Engineer's knowledge, information and belief:
  - a. the Work has progressed to the point indicated;
  - b. the quality of the Work is generally in accordance with the Contract Documents (subject to an evaluation of the Work as a functioning whole prior to or upon Substantial Completion, the results of any subsequent tests called for in the Contract Documents, a final determination of quantities and classifications for Unit Price Work under Paragraph 9.07, and any other qualifications stated in the recommendation); and
  - c. the conditions precedent to Contractor's being entitled to such payment appear to have been fulfilled in so far as it is Engineer's responsibility to observe the Work.
3. By recommending any such payment Engineer will not thereby be deemed to have represented that:
  - a. inspections made to check the quality or the quantity of the Work as it has been performed have been exhaustive, extended to every aspect of the Work in progress, or involved detailed inspections of the Work beyond the responsibilities specifically assigned to Engineer in the Contract Documents; or
  - b. there may not be other matters or issues between the parties that might entitle Contractor to be paid additionally by Owner or entitle Owner to withhold payment to Contractor.

4. Neither Engineer's review of Contractor's Work for the purposes of recommending payments nor Engineer's recommendation of any payment, including final payment, will impose responsibility on Engineer:
  - a. to supervise, direct, or control the Work, or
  - b. for the means, methods, techniques, sequences, or procedures of construction, or the safety precautions and programs incident thereto, or
  - c. for Contractor's failure to comply with Laws and Regulations applicable to Contractor's performance of the Work, or
  - d. to make any examination to ascertain how or for what purposes Contractor has used the moneys paid on account of the Contract Price, or
  - e. to determine that title to any of the Work, materials, or equipment has passed to Owner free and clear of any Liens.
5. Engineer may refuse to recommend the whole or any part of any payment if, in Engineer's opinion, it would be incorrect to make the representations to Owner stated in Paragraph 14.02.B.2. Engineer may also refuse to recommend any such payment or, because of subsequently discovered evidence or the results of subsequent inspections or tests, revise or revoke any such payment recommendation previously made, to such extent as may be necessary in Engineer's opinion to protect Owner from loss because:
  - a. the Work is defective, or completed Work has been damaged, requiring correction or replacement;
  - b. the Contract Price has been reduced by Change Orders;
  - c. Owner has been required to correct defective Work or complete Work in accordance with Paragraph 13.09; or
  - d. Engineer has actual knowledge of the occurrence of any of the events enumerated in Paragraph 15.02.A.

*C. Payment Becomes Due:*

1. Ten days after presentation of the Application for Payment to Owner with Engineer's recommendation, the amount recommended will (subject to the provisions of Paragraph 14.02.D) become due, and when due will be paid by Owner to Contractor.

*D. Reduction in Payment:*

1. Owner may refuse to make payment of the full amount recommended by Engineer because:
  - a. claims have been made against Owner on account of Contractor's performance or furnishing of the Work;
  - b. Liens have been filed in connection with the Work, except where Contractor has delivered a specific bond satisfactory to Owner to secure the satisfaction and discharge

of such Liens;

- c. there are other items entitling Owner to a set-off against the amount recommended; or
  - d. Owner has actual knowledge of the occurrence of any of the events enumerated in Paragraphs 14.02.B.5.a through 14.02.B.5.c or Paragraph 15.02.A.
2. If Owner refuses to make payment of the full amount recommended by Engineer, Owner will give Contractor immediate written notice (with a copy to Engineer) stating the reasons for such action and promptly pay Contractor any amount remaining after deduction of the amount so withheld. Owner shall promptly pay Contractor the amount so withheld, or any adjustment thereto agreed to by Owner and Contractor, when Contractor remedies the reasons for such action.
  3. Upon a subsequent determination that Owner's refusal of payment was not justified, the amount wrongfully withheld shall be treated as an amount due as determined by Paragraph 14.02.C.1 and subject to interest as provided in the Agreement.

#### *14.3 Contractor's Warranty of Title*

- A. Contractor warrants and guarantees that title to all Work, materials, and equipment covered by any Application for Payment, whether incorporated in the Project or not, will pass to Owner no later than the time of payment free and clear of all Liens.

#### *14.4 Substantial Completion*

- A. When Contractor considers the entire Work ready for its intended use Contractor shall notify Owner and Engineer in writing that the entire Work is substantially complete (except for items specifically listed by Contractor as incomplete) and request that Engineer issue a certificate of Substantial Completion.
- B. Promptly after Contractor's notification, Owner, Contractor, and Engineer shall make an inspection of the Work to determine the status of completion. If Engineer does not consider the Work substantially complete, Engineer will notify Contractor in writing giving the reasons therefor.
- C. If Engineer considers the Work substantially complete, Engineer will deliver to Owner a tentative certificate of Substantial Completion which shall fix the date of Substantial Completion. There shall be attached to the certificate a tentative list of items to be completed or corrected before final payment. Owner shall have seven days after receipt of the tentative certificate during which to make written objection to Engineer as to any provisions of the certificate or attached list. If, after considering such objections, Engineer concludes that the Work is not substantially complete, Engineer will, within 14 days after submission of the tentative certificate to Owner, notify Contractor in writing, stating the reasons therefor. If, after consideration of Owner's objections, Engineer considers the Work substantially complete, Engineer will, within said 14 days, execute and deliver to Owner and Contractor a definitive certificate of Substantial Completion; (with a revised tentative list of items to be completed or corrected) reflecting such changes from the tentative certificate as Engineer believes justified after consideration of any objections from Owner. At the time of delivery of the tentative certificate of Substantial Completion, Engineer will deliver to Owner and Contractor a written recommendation as to division of

responsibilities pending final payment between Owner and Contractor with respect to security, operation, safety, and protection of the Work, maintenance, heat, utilities, insurance, and warranties and guarantees. Unless Owner and Contractor agree otherwise in writing and so inform Engineer in writing prior to Engineer's issuing the definitive certificate of Substantial Completion, Engineer's aforesaid recommendation will be binding on Owner and Contractor until final payment.

- D. Owner shall have the right to exclude Contractor from the Site after the date of Substantial Completion subject to allowing Contractor reasonable access to remove its property and complete or correct items on the tentative list.

#### *14.5 Partial Utilization*

- A. Prior to Substantial Completion of all the Work, Owner may use or occupy any substantially completed part of the Work which has specifically been identified in the Contract Documents, or which Owner, Engineer, and Contractor agree constitutes a separately functioning and usable part of the Work that can be used by Owner for its intended purpose without significant interference with Contractor's performance of the remainder of the Work, subject to the following conditions:
1. Owner at any time may request Contractor in writing to permit Owner to use or occupy any such part of the Work which Owner believes to be ready for its intended use and substantially complete. If and when Contractor agrees that such part of the Work is substantially complete, Contractor, Owner, and Engineer will follow the procedures of Paragraph 14.04.A through D for that part of the Work.
  2. Contractor at any time may notify Owner and Engineer in writing that Contractor considers any such part of the Work ready for its intended use and substantially complete and request Engineer to issue a certificate of Substantial Completion for that part of the Work.
  3. Within a reasonable time after either such request, Owner, Contractor, and Engineer shall make an inspection of that part of the Work to determine its status of completion. If Engineer does not consider that part of the Work to be substantially complete, Engineer will notify Owner and Contractor in writing giving the reasons therefor. If Engineer considers that part of the Work to be substantially complete, the provisions of Paragraph 14.04 will apply with respect to certification of Substantial Completion of that part of the Work and the division of responsibility in respect thereof and access thereto.
  4. No use or occupancy or separate operation of part of the Work may occur prior to compliance with the requirements of Paragraph 5.10 regarding property insurance.

#### *14.6 Final Inspection*

- A. Upon written notice from Contractor that the entire Work or an agreed portion thereof is complete, Engineer will promptly make a final inspection with Owner and Contractor and will notify Contractor in writing of all particulars in which this inspection reveals that the Work is incomplete or defective. Contractor shall immediately take such measures as are necessary to complete such Work or remedy such deficiencies.

## 14.7 Final Payment

### A. Application for Payment:

1. After Contractor has, in the opinion of Engineer, satisfactorily completed all corrections identified during the final inspection and has delivered, in accordance with the Contract Documents, all maintenance and operating instructions, schedules, guarantees, bonds, certificates or other evidence of insurance, certificates of inspection, marked-up record documents (as provided in Paragraph 6.12), and other documents, Contractor may make application for final payment following the procedure for progress payments.
2. The final Application for Payment shall be accompanied (except as previously delivered) by:
  - a. all documentation called for in the Contract Documents, including but not limited to the evidence of insurance required by Paragraph 5.04.B.6;
  - b. consent of the surety, if any, to final payment;
  - c. a list of all Claims against Owner that Contractor believes are unsettled; and
  - d. complete and legally effective releases or waivers (satisfactory to Owner) of all Lien rights arising out of or Liens filed in connection with the Work.
3. In lieu of the releases or waivers of Liens specified in Paragraph 14.07.A.2 and as approved by Owner, Contractor may furnish receipts or releases in full and an affidavit of Contractor that: (i) the releases and receipts include all labor, services, material, and equipment for which a Lien could be filed; and (ii) all payrolls, material and equipment bills, and other indebtedness connected with the Work for which Owner might in any way be responsible, or which might in any way result in liens or other burdens on Owner's property, have been paid or otherwise satisfied. If any Subcontractor or Supplier fails to furnish such a release or receipt in full, Contractor may furnish a bond or other collateral satisfactory to Owner to indemnify Owner against any Lien.

### B. Engineer's Review of Application and Acceptance:

1. If, on the basis of Engineer's observation of the Work during construction and final inspection, and Engineer's review of the final Application for Payment and accompanying documentation as required by the Contract Documents, Engineer is satisfied that the Work has been completed and Contractor's other obligations under the Contract Documents have been fulfilled, Engineer will, within ten days after receipt of the final Application for Payment, indicate in writing Engineer's recommendation of payment and present the Application for Payment to Owner for payment. At the same time Engineer will also give written notice to Owner and Contractor that the Work is acceptable subject to the provisions of Paragraph 14.09. Otherwise, Engineer will return the Application for Payment to Contractor, indicating in writing the reasons for refusing to recommend final payment, in which case Contractor shall make the necessary corrections and resubmit the Application for Payment.

### C. Payment Becomes Due:

1. Thirty days after the presentation to Owner of the Application for Payment and accompanying documentation, the amount recommended by Engineer, less any sum Owner is entitled to set off against Engineer's recommendation, including but not limited to liquidated damages, will become due and will be paid by Owner to Contractor.

#### *14.8 Final Completion Delayed*

- A. If, through no fault of Contractor, final completion of the Work is significantly delayed, and if Engineer so confirms, Owner shall, upon receipt of Contractor's final Application for Payment (for Work fully completed and accepted) and recommendation of Engineer, and without terminating the Contract, make payment of the balance due for that portion of the Work fully completed and accepted. If the remaining balance to be held by Owner for Work not fully completed or corrected is less than the retainage stipulated in the Agreement, and if bonds have been furnished as required in Paragraph 5.01, the written consent of the surety to the payment of the balance due for that portion of the Work fully completed and accepted shall be submitted by Contractor to Engineer with the Application for such payment. Such payment shall be made under the terms and conditions governing final payment, except that it shall not constitute a waiver of Claims.

#### *14.9 Waiver of Claims*

- A. The making and acceptance of final payment will constitute:
  1. a waiver of all Claims by Owner against Contractor, except Claims arising from unsettled Liens, from defective Work appearing after final inspection pursuant to Paragraph 14.06, from failure to comply with the Contract Documents or the terms of any special guarantees specified therein, or from Contractor's continuing obligations under the Contract Documents; and
  2. a waiver of all Claims by Contractor against Owner other than those previously made in accordance with the requirements herein and expressly acknowledged by Owner in writing as still unsettled.

### **ARTICLE 15 – SUSPENSION OF WORK AND TERMINATION**

#### *15.1 Owner May Suspend Work*

- A. At any time and without cause, Owner may suspend the Work or any portion thereof for a period of not more than 90 consecutive days by notice in writing to Contractor and Engineer which will fix the date on which Work will be resumed. Contractor shall resume the Work on the date so fixed. Contractor shall be granted an adjustment in the Contract Price or an extension of the Contract Times, or both, directly attributable to any such suspension if Contractor makes a Claim therefor as provided in Paragraph 10.05.

#### *15.2 Owner May Terminate for Cause*

- A. The occurrence of any one or more of the following events will justify termination for cause:

1. Contractor's persistent failure to perform the Work in accordance with the Contract Documents (including, but not limited to, failure to supply sufficient skilled workers or suitable materials or equipment or failure to adhere to the Progress Schedule established under Paragraph 2.07 as adjusted from time to time pursuant to Paragraph 6.04);
  2. Contractor's disregard of Laws or Regulations of any public body having jurisdiction;
  3. Contractor's repeated disregard of the authority of Engineer; or
  4. Contractor's violation in any substantial way of any provisions of the Contract Documents.
- B. If one or more of the events identified in Paragraph 15.02.A occur, Owner may, after giving Contractor (and surety) seven days written notice of its intent to terminate the services of Contractor:
1. exclude Contractor from the Site, and take possession of the Work and of all Contractor's tools, appliances, construction equipment, and machinery at the Site, and use the same to the full extent they could be used by Contractor (without liability to Contractor for trespass or conversion);
  2. incorporate in the Work all materials and equipment stored at the Site or for which Owner has paid Contractor but which are stored elsewhere; and
  3. complete the Work as Owner may deem expedient.
- C. If Owner proceeds as provided in Paragraph 15.02.B, Contractor shall not be entitled to receive any further payment until the Work is completed. If the unpaid balance of the Contract Price exceeds all claims, costs, losses, and damages (including but not limited to all fees and charges of engineers, architects, attorneys, and other professionals and all court or arbitration or other dispute resolution costs) sustained by Owner arising out of or relating to completing the Work, such excess will be paid to Contractor. If such claims, costs, losses, and damages exceed such unpaid balance, Contractor shall pay the difference to Owner. Such claims, costs, losses, and damages incurred by Owner will be reviewed by Engineer as to their reasonableness and, when so approved by Engineer, incorporated in a Change Order. When exercising any rights or remedies under this Paragraph, Owner shall not be required to obtain the lowest price for the Work performed.

- D. Notwithstanding Paragraphs 15.02.B and 15.02.C, Contractor's services will not be terminated if Contractor begins within seven days of receipt of notice of intent to terminate to correct its failure to perform and proceeds diligently to cure such failure within no more than 30 days of receipt of said notice.
- E. Where Contractor's services have been so terminated by Owner, the termination will not affect any rights or remedies of Owner against Contractor then existing or which may thereafter accrue. Any retention or payment of moneys due Contractor by Owner will not release Contractor from liability.
- F. If and to the extent that Contractor has provided a performance bond under the provisions of Paragraph 5.01.A, the termination procedures of that bond shall supersede the provisions of Paragraphs 15.02.B and 15.02.C.

### *15.3 Owner May Terminate For Convenience*

- A. Upon seven days written notice to Contractor and Engineer, Owner may, without cause and without prejudice to any other right or remedy of Owner, terminate the Contract. In such case, Contractor shall be paid for (without duplication of any items):
  - 1. completed and acceptable Work executed in accordance with the Contract Documents prior to the effective date of termination, including fair and reasonable sums for overhead and profit on such Work;
  - 2. expenses sustained prior to the effective date of termination in performing services and furnishing labor, materials, or equipment as required by the Contract Documents in connection with uncompleted Work, plus fair and reasonable sums for overhead and profit on such expenses;
  - 3. all claims, costs, losses, and damages (including but not limited to all fees and charges of engineers, architects, attorneys, and other professionals and all court or arbitration or other dispute resolution costs) incurred in settlement of terminated contracts with Subcontractors, Suppliers, and others; and
  - 4. reasonable expenses directly attributable to termination.
- B. Contractor shall not be paid on account of loss of anticipated profits or revenue or other economic loss arising out of or resulting from such termination.

### *15.4 Contractor May Stop Work or Terminate*

- A. If, through no act or fault of Contractor, (i) the Work is suspended for more than 90 consecutive days by Owner or under an order of court or other public authority, or (ii) Engineer fails to act on any Application for Payment within 30 days after it is submitted, or (iii) Owner fails for 30 days to pay Contractor any sum finally determined to be due, then Contractor may, upon seven days written notice to Owner and Engineer, and provided Owner or Engineer do not remedy such suspension or failure within that time, terminate the Contract and recover from Owner payment on the same terms as provided in Paragraph 15.03.

- B. In lieu of terminating the Contract and without prejudice to any other right or remedy, if Engineer has failed to act on an Application for Payment within 30 days after it is submitted, or Owner has failed for 30 days to pay Contractor any sum finally determined to be due, Contractor may, seven days after written notice to Owner and Engineer, stop the Work until payment is made of all such amounts due Contractor, including interest thereon. The provisions of this Paragraph 15.04 are not intended to preclude Contractor from making a Claim under Paragraph 10.05 for an adjustment in Contract Price or Contract Times or otherwise for expenses or damage directly attributable to Contractor's stopping the Work as permitted by this Paragraph.

## **ARTICLE 16 – DISPUTE RESOLUTION**

### *16.1 Methods and Procedures*

- A. Either Owner or Contractor may request mediation of any Claim submitted to Engineer for a decision under Paragraph 10.05 before such decision becomes final and binding. The mediation will be governed by the Construction Industry Mediation Rules of the American Arbitration Association in effect as of the Effective Date of the Agreement. The request for mediation shall be submitted in writing to the American Arbitration Association and the other party to the Contract. Timely submission of the request shall stay the effect of Paragraph 10.05.E.
- B. Owner and Contractor shall participate in the mediation process in good faith. The process shall be concluded within 60 days of filing of the request. The date of termination of the mediation shall be determined by application of the mediation rules referenced above.
- C. If the Claim is not resolved by mediation, Engineer's action under Paragraph 10.05.C or a denial pursuant to Paragraphs 10.05.C.3 or 10.05.D shall become final and binding 30 days after termination of the mediation unless, within that time period, Owner or Contractor:
1. elects in writing to invoke any dispute resolution process provided for in the Supplementary Conditions; or
  2. agrees with the other party to submit the Claim to another dispute resolution process; or
  3. gives written notice to the other party of the intent to submit the Claim to a court of competent jurisdiction.

## **ARTICLE 17 – MISCELLANEOUS**

### *17.1 Giving Notice*

- A. Whenever any provision of the Contract Documents requires the giving of written notice, it will be deemed to have been validly given if:

1. delivered in person to the individual or to a member of the firm or to an officer of the corporation for whom it is intended; or
2. delivered at or sent by registered or certified mail, postage prepaid, to the last business address known to the giver of the notice.

#### *17.2 Computation of Times*

- A. When any period of time is referred to in the Contract Documents by days, it will be computed to exclude the first and include the last day of such period. If the last day of any such period falls on a Saturday or Sunday or on a day made a legal holiday by the law of the applicable jurisdiction, such day will be omitted from the computation.

#### *17.3 Cumulative Remedies*

- A. The duties and obligations imposed by these General Conditions and the rights and remedies available hereunder to the parties hereto are in addition to, and are not to be construed in any way as a limitation of, any rights and remedies available to any or all of them which are otherwise imposed or available by Laws or Regulations, by special warranty or guarantee, or by other provisions of the Contract Documents. The provisions of this Paragraph will be as effective as if repeated specifically in the Contract Documents in connection with each particular duty, obligation, right, and remedy to which they apply.

#### *17.4 Survival of Obligations*

- A. All representations, indemnifications, warranties, and guarantees made in, required by, or given in accordance with the Contract Documents, as well as all continuing obligations indicated in the Contract Documents, will survive final payment, completion, and acceptance of the Work or termination or completion of the Contract or termination of the services of Contractor.

#### *17.5 Controlling Law*

- A. This Contract is to be governed by the law of the state in which the Project is located.

#### *17.6 Headings*

- A. Article and paragraph headings are inserted for convenience only and do not constitute parts of these General Conditions.

**END OF SECTION**

## SECTION 00800

### SUPPLEMENTARY CONDITIONS

#### 1. DEFINITIONS

Add the following:

The term(s) "**or equal**" or "**approved equal**," shall be interpreted to mean an item or material or equipment similar to that named and which is suited to the same use and capable of performing the same function and be of the same quality as that named. Such material or equipment shall be subject to approval by the Engineer.

The term **Acceptance**, shall be interpreted to mean that the OWNER of the work is satisfied that it is fully complete and in accordance with the Contract Documents.

The term **Affidavit**, shall be interpreted as the instrument which is to be signed by the Contractor and submitted to the OWNER through the Engineer, upon completion of that job, showing that all bills have been paid. It shall also mean such instrument that may be requested by the OWNER incident to partial payments.

The term **Approval** shall be interpreted as the item in question is accepted as satisfactory.

The term **Article**, shall be interpreted as the prime subdivision of a section of these or any other Specifications, the instructions to Bidders, the Special Conditions and the General Conditions.

The term "**Provided**," as used in the Specifications upon the Drawings, shall be understood to mean "provided complete in place," that is, "furnished and installed." Where "as shown," "as indicated," "as detailed," or words of similar importance are used, it shall be understood that the references to the Drawings and/or Specifications accompanying these documents are intended unless otherwise expressly stated.

The words "**furnish**," "**furnish and**," "**install**," and "**provide**" or words with similar meaning shall be interpreted unless otherwise specifically stated, to mean "furnish and install complete in place and ready for service."

#### 2. AWARD OF CONTRACT

The award of the contract, if it is awarded, will be to the lowest responsible, responsive Bidder. No Notice of Award will be given until the OWNER has concluded such investigations as he deems necessary to establish the responsibility, qualifications and financial ability of the Bidders to do the Work in accordance with the Contract Documents to the satisfaction of the OWNER within the time prescribed. The OWNER reserves the right to reject the Bid of any Bidder who does not pass such investigation to the OWNER's satisfaction. In analyzing Bids, the OWNER may take into consideration alternates and unit prices, if requested by the Bid forms. If the Contract is awarded, the OWNER will issue the Notice of Award and give the successful Bidder a contract for execution within one hundred and twenty (120) days after the opening of Bids.

#### 3. FORFEITURE OF BID SECURITY

Failure of the successful Bidder to execute and deliver the Agreement and deliver the required Bonds to the OWNER within 10 working days or 15 calendar days of receipt of the Agreement from the Owner, shall be just cause for the OWNER to annul the Notice of Award and declare the Bid and any security therefore forfeited.

4. QUALIFICATION OF SUB CONTRACTORS METERIALMEN AND SUPPLIERS

Within ten working days after bid opening, the CONTRACTOR will submit to the OWNER and the ENGINEER for acceptance a list of the names of sub contractors and such other persons and organizations (including those who are to furnish principal items of materials or equipment) proposed for those portions of the work as to which the identity of the subcontractors and other persons and organizations must be submitted as specified in the Contract Documents. Within thirty working days after receiving the list, the ENGINEER will notify the CONTRACTOR in writing if either the OWNER or the ENGINEER, after due investigation, has reasonable objection to any subcontractor, person or organization on such list. The failure of the OWNER or the ENGINEER to make objection to any subcontractor, person or organization on the list within thirty days of receipt shall constitute an acceptance of such subcontractor, person or organization. Acceptance of any such subcontractor, person or organization shall not constitute a waiver of any right of the OWNER or the ENGINEER to reject defective work, material or equipment or work material or equipment not in conformance with the requirements of the contract documents.

5. DELIVERY OF BONDS

Add to paragraph 2.1

Failure of the successful Bidder to execute the Agreement and deliver the required Bonds within ten (10) days of the Notice of Award shall be just cause for the Owner to annul the award and declare the Bid and any guarantee thereof forfeited.

6. COPIES OF DOCUMENTS

Add the following to paragraph 2.2

The Contractor will be furnished, free of charge, up to five (5) copies of the drawings and specifications in lieu of the ten (10) copies as stated.

7. CHANGE OF THE CONTRACT TIME

Add paragraph 12.4

Because this is a calendar day contract, normal rainfall, weather and climatic conditions, which may be reasonably expected, are not considered grounds for an extension of contract time.

8. PAYMENTS TO CONTRACTOR AND COMPLETION

Add the following to paragraph 14.13

The certificate of completion will not be issued nor the final payments made until ALL punch list items have been completed.

9. CONTRACTOR'S LIABILITY INSURANCE

Refer to General Condition 5.3

The Contractor will, at his own expense, purchase and maintain such insurance as will protect the Owner and the Contractor from claims under workmen's compensation laws, disability benefit laws or other similar employee laws; from claims for damages because of bodily injury, occupational sickness or disease, or death of his employees, or any person other than his employees, including claims insured by usual personal injury liability coverage; from claims for injury to or destruction of tangible property including loss of use resulting therefrom – any or all of which may arise out of or result from the Contractor's operations under the Contract Documents, whether such operations be by any Subcontractor or anyone directly or indirectly employed by any of them or for whose acts may be legally liable. This insurance shall be written for not less than \$1,000,000.00 combined single limit per occurrence (no aggregate limitation) or as required by law, whichever is greater, and shall include contractual liability insurance. Before starting the work, the Contractor will file with the Owner and Engineer certificates of such insurance, acceptable to the Owner; these certificates shall contain a provision that the coverage afforded under the policies will not be canceled or materially changed until at least 15 days after written notice is given to the Owner and Engineer. These policies shall be written to cover the Contractor and Owner jointly. The Certificate of Insurance form is included in Section 00650.

10. OWNERS INDEMNITY

Refer to General Conditions 6.30 through 6.32

- A. The Contractor shall obtain, maintain and furnish to the Owner during the life of this Contract, full Owner's Protective Liability Insurance that will protect him against all losses or claims which may arise from operations under the Contract Documents.
- B. To the fullest extent permitted by law, the CONTRACTOR shall indemnify, defend, and hold harmless the OWNER, the ENGINEER, and their officers, agents, and employees, against and from all claims and liability arising under or by reason of the Contract or any performance of the WORK, but not from the sole negligence or willful misconduct of the OWNER and/or the ENGINEER. Such indemnification by the CONTRACTOR shall include but not be limited to the following:
  - 1. Liability or claims resulting directly or indirectly from the negligence or carelessness of the CONTRACTOR or its agents in the performance of the WORK, or in guarding or maintaining the same, or from any improper materials, implements, or appliances used in its construction, or by or on account of any act or omission of the contractor or its agents;
  - 2. Liability or claims arising directly or indirectly from or based on the violation of any law, ordinance, regulation, order, or decree, whether by the CONTRACTOR or its agents;
  - 3. Liability or claims arising directly or indirectly from the use or manufacture by the CONTRACTOR, its agents, or the OWNER in the performance of this Contract of any copyrighted composition, secret process, patented or unpatented invention, article, or appliance, unless otherwise specifically stipulated in this Contract;
  - 4. Liability or claims arising directly or indirectly from the breach of any warranties, whether expressed or implied, made to the OWNER or any other parties by the CONTRACTOR or its agents;

5. Liabilities or claims arising directly or indirectly from the willful misconduct of the CONTRACTOR or its agents; and
6. Liabilities or claims arising directly or indirectly from any breach of the obligations assumed herein by the CONTRACTOR.
- C. The CONTRACTOR shall reimburse the OWNER, and the ENGINEER for all costs and expenses, (including but not limited to fees and charges of engineers, architects, attorneys, and other professionals and court costs) incurred by said OWNER, and the ENGINEER in enforcing the provisions of this Paragraph.
- D. The indemnification obligation under this Paragraph shall not be limited in any way by any limitation of the amount or type of damages, compensation, or benefits payable by or for the CONTRACTOR or any such subcontractor or other person or organization under worker's compensation acts, disability benefit acts, or other employees benefit acts.

#### 11. PROPERTY INSURANCE

Refer to General Conditions 5.6

- A. The Contractor shall, at his own expense, obtain and maintain property insurance and furnish to the Owner during the life of this Contract the full insurable value of the project. This insurance shall include the interests of the Owner, the Contractor and Subcontractors in the work shall insure against the perils of Fire, Extended Coverage, Vandalism and Malicious Mischief.
- B. The Owner and Contractor waive all rights against each other for damages caused by fire or other perils to the extent covered by insurance provided under this Article, except such rights as they may have to the proceeds of such insurance. The Contractor shall require similar waivers by Subcontractors.

#### 12. SALES TAX

Refer to General Conditions 6.15

The Contractor shall familiarize himself with the requirements and procedures as applicable of the State of Florida pertaining to the exemption from State Sales Tax as it may apply to the Owner.

#### 13. INDEMNITY

Refer to General Conditions 6.30 – 6.32

The Bid Items for Payment and Performance Bond premium and consideration for indemnification to Owner and Engineer are included in the Schedule of Prices and must be completed by the Bidder in order to comply with Florida Statute 725.06.

#### 14. OWNER'S RESPONSIBILITY

Refer to General Condition 8.5

Delete Paragraph 8.5 of the General Conditions in its entirety.

#### 15. SUBSTANTIAL COMPLETION

Refer to General Conditions 14.8 and 14.9

- A. Amend the first three lines of Paragraph 14.8 of the General Conditions to read as follows: "When CONTRACTOR" considers the part of the Work described for Beneficial Occupancy in Section 00000 ready for its intended use CONTRACTOR shall in writing to OWNER and ENGINEER, certify that such Work is....."
- B. Amend Paragraph 14.9 of the General Conditions to read as follows: "Owner shall have the right to exclude CONTRACTOR from the substantially completed portion of the Work after the date of Substantial Completion, but OWNER shall allow CONTRACTOR reasonable access to complete or correct items on the tentative list."

#### 16. PERMITS

The Contractor will be required to obtain all required permits, including a permit from the City of West Park Building and Zoning Department, prior to the start of construction.

#### 17. LAWS AND REGULATIONS

Refer to General Conditions 6.14

The Contractor shall obey all applicable Federal, State and local laws including but not limited to the ones listed below.

The Contractor shall comply with Executive Order No. 11246, entitled "Equal Opportunity Employment," as amended by Executive Order No. 11275, and as supplemented in Department of Labor Regulations (No. 41 CFR, Chapter 60).

The Copeland "Anti-Kickback" Act (18 U.S.C. Section 874), as supplemented in U.S. Department of Labor Regulations (29 CFR, Chapter 60).

All applicable standards, orders or regulations issued pursuant to the Clean Air Act of 1970 (40 U.S.C. Section 1857 et seq.) as amended and the Federal Water Pollution Control Act (33 U.S.C. Section 1251 et seq.) as amended.

The Florida State Statute 446.101 Apprentice and Training Employment Regulations.

Florida Industrial Code No. 8C as amended and especially 8C-29 (CB-1958), Florida Department of Commerce, Bureau of Workmen's Compensation.

#### 18. REVIEW OF APPLICATIONS FOR PROGRESS PAYMENTS

Refer to General Conditions 14.4

Owner shall, within sixty (60) days of presentation to him of the Application for Payment with Engineer's recommendation pay Contractor the amount recommended. This is in lieu of 10 days.

19. PARTIAL AND FINAL PAYMENT PROCEDURES

Refer to General Conditions 14.4 and 14.13

- A. If the work progresses according to this Contract, the Contractor will be paid each month, 90 percent of the value of the work completed during the preceding month and 90 percent of the value of the materials not already used, but which have been furnished by the Contractor under the Specifications and satisfactorily stored on the project site, provided that such materials have been delivered and inspected and that payment therefor has been satisfactorily certified by the Contractor to the Owner and provided further that the materials, in the judgment of the Owner's Engineer are such as probably will be incorporated in the work within the next 30 days. The Contractor shall substantiate the value of stored materials for which payment is requested by submitting copies of suppliers' invoices for the stored material. For the purpose of preparing a monthly estimate for partial payment, the Contractor will make an approximate estimate of the value of all work done and materials furnished as of the last day of each calendar month, and will deduct 10 percent thereof and all previous payments and charges, and the balance will be paid by the Owner to the Contractor on or about thirty days after the submittal to the Owner. The Owner's Engineer shall review, revise and correct, if necessary, and then approve the estimate for partial payment before it is submitted by the Owner's Engineer to the Owner. The 10 percent, which are deducted each month, are reserved by the Owner as a partial guarantee to it of the faithful execution of this Contract. As a consideration of such payment of 90 percent, the Owner shall have the right to enter upon and put into proper service any or all parts of the work which may be in condition for use; however, such use shall not be construed as the final acceptance and the commencement of the one year guarantee bond period for any or all parts of the work, unless final acceptance is made for the complete project at that time. No claim or charge is to be made by the Contractor for such use, nor is such use to be construed as an acceptance by the Owner of any part of the work so used.
- B. Upon receipt of written notice from the Contractor that the work has been completed in conformity with the Drawings and Specifications and any approved changes thereto, the Owner's Engineer shall promptly examine the work and, making such tests as he may deem proper and using all of the care and judgment normally exercised in the examination of completed work by a properly qualified and experienced professional engineer, shall satisfy himself that the Contractor's statement appears to be correct. He shall then inform the Owner in writing that he has examined the work and that it appears to conform to the Contract Drawings, Specifications and any approved Change Orders and that therefore he recommends acceptance and final payment to the Contractor. However, it is agreed by the Owner and the Contractor that such statement by the Owner's Engineer does not in any way relieve the Contractor from his responsibility to deliver a completed job in good and workmanlike condition, and does not render the Engineer or the Owner liable for any faulty work done or materials used by the Contractor.
- C. The Owner's Engineer will then make a final estimate of the value of all work done and will deduct therefrom all previous payments, which have been made. The Owner's Engineer will report such estimate to the Owner together with his recommendation as to the acceptance of the work or his findings as to any deficiencies therein. Such recommendation as to the acceptance of the work by the Owner's Engineer will be made to his best knowledge and behalf. After receipt and acceptance by the Owner of the properly executed Affidavit and the Release of Lien and within 60 days after approval of the Engineer's estimate and recommendation by the Owner, the amount of the estimate, less any charges or damages herein provided for, will be paid. Upon such final payment, the Owner shall be released by the Contractor from all liability whatever growing out of this Contract, except for the balance, if any, of such amount as may have been retained to

cover charges, claims or damages, as specified; and if the Owner is satisfied that no such charges, claims or damages exist or will arise, no such amount will be retained. All prior estimates are subject to correction in the final estimate.

- D. Each request for a partial payment shall be submitted on an Application for Payment Form shown on Page 00800-08-09 which shall be accompanied by an executed copy of the Certification of Contractor shown on Page 00800-12.
- E. Measurement and payment for work items for which direct payment is provided will be achieved as required by the Technical Specifications. When no direct payment for work or materials is required in General Conditions, the Special Conditions, the Proposal, the sections of the Technical Specifications or in other parts of the Contract Documents or shown, indicated or noted on the Drawings, compensation therefor shall be included in the Contract Unit or Lump Sum Prices for the several pay items under this Contract and shown and listed in the Proposal.
- F. When the work has been completed, the Contractor shall execute a Final Release of Lien and an Affidavit declaring that all bills have been paid in full.
- G. These final documents will be furnished to the Owner in a form similar to those that appear on Pages 00800-10 and 14.

**END OF SECTION**

APPLICATION FOR PAYMENT (SAMPLE) OR AIA G702

Date: \_\_\_\_\_

APPLICATION FOR PAYMENT NO. \_\_\_\_\_

To: \_\_\_\_\_ (OWNER) Project No.: \_\_\_\_\_  
From: \_\_\_\_\_ (CONTRACTOR)  
Contract for: \_\_\_\_\_  
\_\_\_\_\_

For work accomplished through the date of: \_\_\_\_\_, 200\_\_\_\_.

SUMMARY OF CONTRACT AMOUNTS

- 1. Original Contract Price : ..... \$ \_\_\_\_\_
- 2. Change Orders No. Through : ..... \$ \_\_\_\_\_
- 3. Contract Price with all approved Change Orders : ..... \$ \_\_\_\_\_
- 4. Work completed to date : ..... \$ \_\_\_\_\_
- 5. Less (10%) Retainage : ..... \$ \_\_\_\_\_
- 6. Amount due to date : ..... \$ \_\_\_\_\_
- 7. Less previous payments (or applications) : ..... \$ \_\_\_\_\_
- 8. AMOUNT DUE THIS APPLICATION: ..... \$ \_\_\_\_\_

Note: *This application must be accompanied with the Certification of Contractor Form  
And worksheet for completed items as shown on Page 00000- .*

Accompanying Documentation: \_\_\_\_\_  
\_\_\_\_\_  
\_\_\_\_\_  
\_\_\_\_\_

---

Payment of the above AMOUNT DUE THIS APPLICATION is recommended.

Dated: \_\_\_\_\_, 200\_\_\_\_

\_\_\_\_\_  
\_\_\_\_\_

By: \_\_\_\_\_  
Project Manager

**APPLICATION FOR PAYMENT NO.**

**CONTRACTOR'S SCHEDULE OF COMPLETED WORK ITEMS**

**SAMPLE (OR AIA G703)**

Project: \_\_\_\_\_ Sheet \_\_\_\_\_ of \_\_\_\_\_

Owner's Contract No.: \_\_\_\_\_ Engineer's Project No.: \_\_\_\_\_

For work accomplished through the date of: \_\_\_\_\_ 20 .

Item No.	Description	ORIGINAL CONTRACT QUANTITIES				WORK COMPLETED	
		Quantity	Unit	Unit Price	Amount	Quantity	Amount
	Total (Original Contract)				\$ -		\$ -
	Change Order No. 1:				\$ -		\$ -
	Change Order No. 2:				\$ -		\$ -
	PROJECT TOTAL:				\$ -		\$ -

**AFFIDAVIT**

STATE OF FLORIDA            )  
  : ss  
COUNTY OF BROWARD        )

Before me, the undersigned authority to administer oaths and take acknowledgements, personally appeared \_\_\_\_\_, who, after being first duly sworn, upon oath deposes and says that all lienors contracting directly with, or directly employed by (him, them, it) and that all taxes imposed by Chapter 212, Florida Statutes (Sales and Use Tax Act) as amended, have been paid and discharged, and that all bills, wages, fees, claims and other charges incurred by \_\_\_\_\_ in connection with the construction of \_\_\_\_\_ have been paid in full.

SIGNED: \_\_\_\_\_

By: \_\_\_\_\_

WITNESSES:

\_\_\_\_\_  
\_\_\_\_\_

SWORN AND SUBSCRIBED TO BEFORE ME THIS \_\_\_\_\_ day of \_\_\_\_\_, 20\_\_ A.D.

\_\_\_\_\_  
Notary Public  
State of Florida at Large  
  
My Commission Expires:  
\_\_\_\_\_

**END OF SECTION**

**AFFIDAVIT REGARDING EQUIPMENT STORAGE AND STAGING YARD**

The undersigned agrees to secure prior to construction an off-site equipment storage and staging yard (lot) outside of the public right of way. The expense for this yard shall be included as part of bid item 4.06 Mobilization.

The undersigned further agrees to avoid overnight storage of equipment in the public right-of- way. Failure to comply with this requirement shall result in a penalty in the amount of \$250 per incident plus any costs incurred by the City. Furthermore, the City reserves the right to have towed away any equipment left in the right-of way overnight at the bidder’s expense. The undersigned agrees to pay any additional cost incurred to retrieve towed and impounded equipment.

By: \_\_\_\_\_ Date \_\_\_\_\_  
Signature of Bidder

\_\_\_\_\_  
Printed Name of Bidder and Title

\_\_\_\_\_  
Printed Name of the Firm

\_\_\_\_\_  
Address of the Firm

The foregoing instrument was acknowledged before me the \_\_\_\_ day of \_\_\_\_\_, 20 \_\_, by

\_\_\_\_\_  
(Authorized Representative)

of \_\_\_\_\_, who is personally known to me or who  
(Corporation, Partnership, etc.)

has produced \_\_\_\_\_ as identification and who did/did not take an oath.

\_\_\_\_\_  
(Signature of Notary)

\_\_\_\_\_  
Serial Number

\_\_\_\_\_  
(Print of Stamp Name of Notary)

\_\_\_\_\_  
(Expiration Date)

Notary Public – State of \_\_\_\_\_

**END OF SECTION**

CERTIFICATION OF CONTRACTOR

According to the best of my knowledge and belief, I certify that all items and amounts shown on Application for Payment No. \_\_\_\_\_ are correct, that all work has been performed and/or materials supplied in full accordance with the terms and conditions of this Contract, dated \_\_\_\_\_, 20\_\_\_\_, between \_\_\_\_\_ (Owner) and \_\_\_\_\_ (Contractor).

I further certify that all just and lawful bills against the undersigned and his subcontractors and suppliers for labor, material and equipment employed in the performance of this Contract have been paid in full accordance with their terms and conditions; that all taxes imposed by Chapter 212, Florida Statutes (Sales and Use Tax Act), as amended, have been paid and discharged; and that there are no Vendor's, Mechanic's or other Liens or rights to liens or conditional sales contracts which should be satisfied or discharged before such payment is made.

Date: \_\_\_\_\_

Contractor: \_\_\_\_\_

STATE OF FLORIDA )  
 : ss  
COUNTY OF BROWARD )

Personally appeared before me this \_\_\_\_\_ day of \_\_\_\_\_, 20\_\_\_\_.

\_\_\_\_\_ known (or made known) to me as the \_\_\_\_\_ (Owner) (Partner) (Corporate Officer) - Give Title of \_\_\_\_\_ (Contractor(s), who subscribed and swore to the above instrument in my presence.

\_\_\_\_\_  
Notary Public  
State of Florida at Large

My Commission Expires:  
\_\_\_\_\_

END OF SECTION

PARTIAL RELEASE OF LEIN

KNOW ALL MEN BY THESE PRESENTS, that \_\_\_\_\_ for and in consideration of the sum of \_\_\_\_\_ Dollars (\$ \_\_\_\_\_) paid to \_\_\_\_\_ by the \_\_\_\_\_, receipt of which is hereby acknowledged, do(es) hereby release and quitclaim to the City of West Park, the Owner, its successors or assigns, all liens, lien rights, claims or demands of any kind whatsoever which \_\_\_\_\_ now has (have) or have against the property, building, and/or for any incidental expense for the construction of:

\_\_\_\_\_  
\_\_\_\_\_  
\_\_\_\_\_

thereon or in otherwise improving said property situated as above described.

IN WITNESS WHEREOF \_\_\_\_\_ have (has) hereunto set \_\_\_\_ hand and seal \_\_\_\_ this \_\_\_\_\_ day of \_\_\_\_\_, 20\_\_\_. A.D.

WITNESS:

\_\_\_\_\_ (Seal)

SWORN AND SUBSCRIBED TO BEFORE ME THIS \_\_\_\_\_ day of \_\_\_\_\_, 20\_\_\_. A.D.

\_\_\_\_\_  
Notary Public State of Florida at Large  
My Commission Expires:  
\_\_\_\_\_

END OF SECTION

FINAL RELEASE OF LEIN

KNOW ALL MEN BY THESE PRESENTS, that \_\_\_\_\_  
\_\_\_\_\_ for and in consideration of the sum of  
\_\_\_\_\_ Dollars (\$\_\_\_\_\_) )  
paid to \_\_\_\_\_ by the \_\_\_\_\_, receipt of which is  
hereby acknowledged, do(es) hereby release and quitclaim to the City of West Park, the Owner, its  
successors or assigns, all liens, lien rights, claims or demands of any kind whatsoever  
which \_\_\_\_\_ now has (have) or have against the property, building, and/or for any  
incidental expense for the construction of:

\_\_\_\_\_  
\_\_\_\_\_  
\_\_\_\_\_

thereon or in otherwise improving said property situated as above described.

IN WITNESS WHEREOF \_\_\_\_\_ have (has) hereunto  
set \_\_\_ hand and seal \_\_\_ this \_\_\_\_\_ day of \_\_\_\_\_, 20\_\_\_. A.D.

WITNESS:

\_\_\_\_\_ (Seal)

SWORN AND SUBSCRIBED TO BEFORE ME THIS \_\_\_\_\_ day of \_\_\_\_\_, 20\_\_\_. A.D.

\_\_\_\_\_  
Notary Public  
State of Florida at Large  
My Commission Expires:

\_\_\_\_\_

END OF SECTION

SECTION 00900

ADDENDUM

SECTION 00950

PROJECT SIGN

## Appendix V – Sample Project Sign

Contractor shall furnish and erect a sign at the project site. The sign shall be made of 3/4-inch plywood, substantially in accordance with the drawings on next page. Sign shall be placed in a prominent location and maintained in good condition until completion of the project.

**Sign Dimensions: 1200mm x 2400mm x 19 mm (app. 4' x 8' x 3/4") Plywood Panel (APA Rated A-B grade – Exterior)**

**Colors: Background – Egg Shell (Off-White) Boarder and Lettering - Navy**

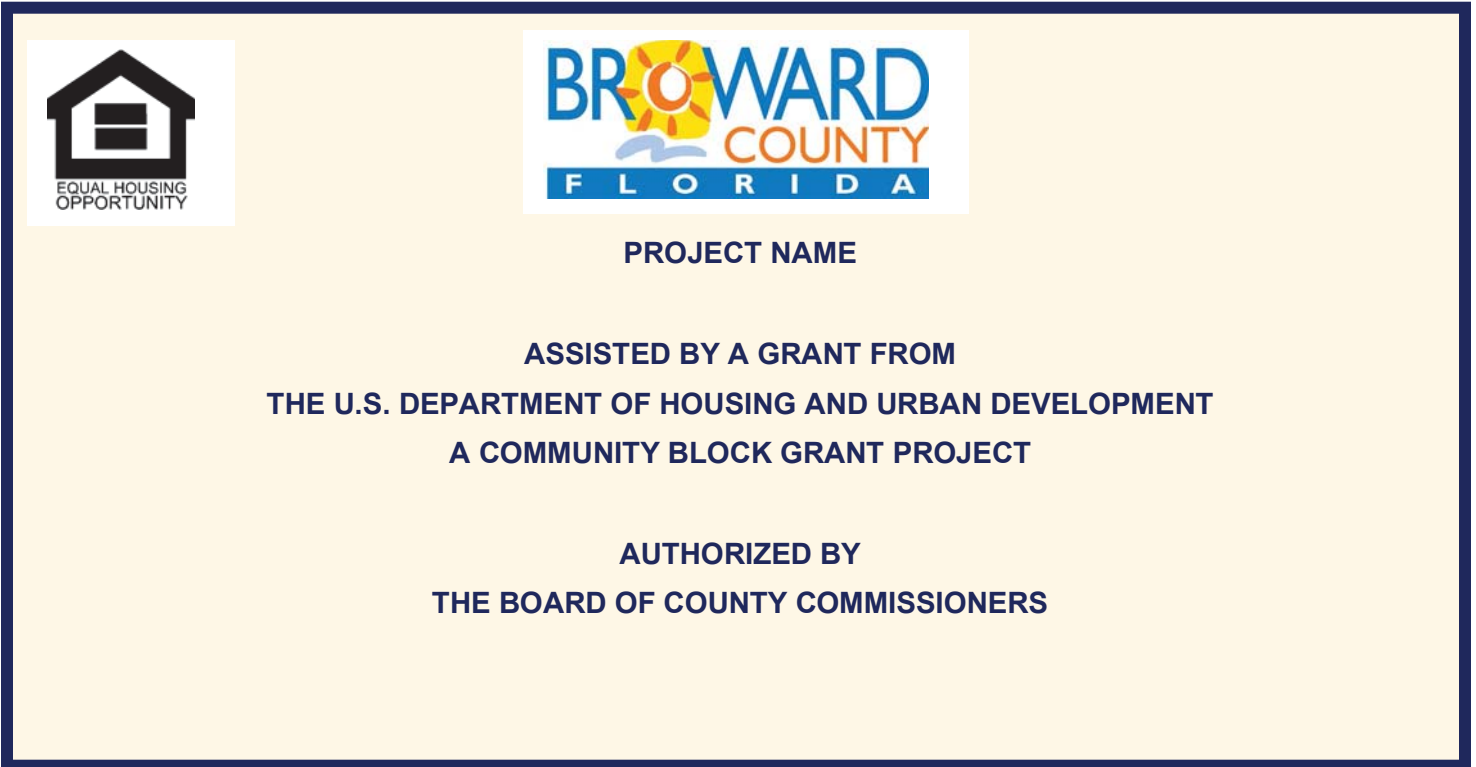

## SECTION 01000

### GENERAL REQUIREMENT

#### **PART 1      GENERAL**

##### **1.1          DESCRIPTION OF WORK**

- A. The Contractor shall furnish all labor, superintendence, materials, fuel, water, tools, appliances, equipment, supplies, and other means of construction necessary or proper for performance and completion of all work included in this Contract. The Contractor shall perform and complete the work in the manner best calculated to promote rapid construction consistent with safety of life and property and to the satisfaction of the Owner and Engineer, and in strict accordance with the Contract Documents. The Contractor shall clean up the work and maintain it during and after construction, until accepted, and shall do all work and pay all costs incidental thereto. The Contractor shall repair or restore all structures and property that may be damaged or disturbed during performance of the work. The Contractor shall obtain any and all required permits, inspections, and pay any fees for the purpose of this project. All secondary or trade permits shall be the responsibility of the Contractor. The Contractor will adhere to all applicable federal, state, and local codes and ordinances for the construction of the project as well as the requirements and specifications indicated in the contract.
- B. The cost of incidental work described in these GENERAL REQUIREMENTS, for which there are no specific Contract Items, shall be considered as part of the general cost of doing the work and shall be included in the prices for the various Contract Items. No additional payment will be made therefor.
- C. Omission of a specific item or component part of a system obviously necessary for the proper functioning of the system shall not relieve the Contractor of the responsibility of furnishing the item as part of the work at no additional cost to Owner.
- D. Where portions of the work traverse or cross federal, state, county or local highways, roads, streets, or waterways, and the agency in control of such property has established standard specifications governing items of work that differ from these specifications, the most stringent requirements shall apply.
- E. Public utility installations and structures shall be understood to include all poles, tracks, pipes, wires, conduits, house service connections, vaults, manholes and all other appurtenances and facilities pertaining thereto whether owned or controlled by the Owner, other governmental bodies or privately owned by individuals, firms or corporations, used to serve the public with transportation, traffic control, gas, electricity, telephone, sewerage, drainage, water or other public or private property which may be affected by the work shall be deemed included hereunder.
- F. The Contract Documents contain data relative to existing public utility installations and structures above and below the ground surface. These data are not guaranteed as to their completeness or accuracy and it is the responsibility of the Contractor to make his own investigations to inform himself fully of the character, condition and extent of all such installations and structures as may be encountered and as may affect the construction operations.

- G. The Contractor shall protect all public utility installations and structures from damage during the work. The Contractor shall so arrange his operations as to avoid any damage to these facilities. All required protective devices and construction including but not limited to temporary pipe supports shall be provided by the Contractor at his expense. All existing public utilities damaged by the Contractor which are shown on the Plans or have been located in the field by the utility shall be repaired by the Contractor, at his expense, as directed by the Owner or Engineer. No separate payment shall be made for such protective devices or repairs to public utility installations or structures.
- H. The Contractor shall be solely and directly responsible to the Owner and operators of such properties for any damage, injury, expense, loss, inconvenience, delay, suits, actions or claims of any character brought because of any injuries or damage which may result from the construction operations under this Contract.
- I. Neither the Owner nor its officers or agents shall be responsible to the Contractor for damages as a result of the Contractor's failure to protect utilities encountered in the work.
- J. Public utility installations or structures owned or controlled by the Owner or another governmental body which are shown to be removed, relocated, replaced or rebuilt by the Contractor shall be considered as a part of the general cost of doing the work and shall be included in the prices bid for the various contract items. No separate payment shall be made therefore.
- K. Where public utility installations or structures owned or controlled by the Owner, another governmental body or public agency are encountered during the course of the work, and are not indicated on the Drawings or in the Specifications, and when, in the opinion of the Owner or Engineer, removal, relocation, replacement or rebuilding is necessary to complete the work under this Contract, such work shall be accomplished by the utility having jurisdiction, or such work may be ordered, in writing by the utility for the Contractor to accomplish. If such work is accomplished by the utility having jurisdiction, it will be carried out expeditiously and the Contractor shall give full cooperation to permit the utility to complete the removal, relocation, replacement or rebuilding as required. If such work is accomplished by the Contractor, it will be paid for as extra work as provided in the Agreement.
- L. In the event of interruption to domestic water, sewer, storm drain or other utility services as a result of accidental breakage due to construction operations, promptly notify the proper authority. Cooperate with said authority in restoration of service as promptly as possible and bear all costs of repair. In no case shall interruption of any water or utility service be allowed to exist outside working hours unless approval is granted prior to beginning construction.
- O. The Contractor shall, at all times in performance of the work, employ approved methods and exercise reasonable care and skill so as to avoid unnecessary delay, injury, damage or destruction of public utility installations and structures; and shall, at all times in the performance of the work, avoid unnecessary interference with, or interruption of, public utility services, and shall cooperate fully with the Owners thereof to that end.
- P. The maintenance, repair, removal, relocation or rebuilding of public utility installations and structures, when accomplished by the Contractor as herein provided, shall be done by methods approved by the owner of the utility.



1. Contractor shall notify the City of West Park Public Works Department 48 hours prior to the start of construction.
  2. Contractor shall be responsible for verifying all utility locations prior to commencement of construction.
  3. The Contractor shall notify the Engineer immediately, in writing, of any conflicts between the project work and any existing utility. The Engineer may request additional potholes at any time.
- B. Continuous operation of the Owner's existing system is of critical importance. Connections to existing services of utilities, or other work that requires the temporary shutdown of any existing operations or utilities, shall be planned in detail with appropriate scheduling of the work and coordinated with the Owner or Engineer.
- C. All materials and equipment (including emergency equipment) necessary to expedite the tie-in shall be on hand prior to the shutdown of existing services or utilities.
- D. At no time shall the Contractor undertake to close off any lines or open valves or take any other action that would affect the operation of the existing system, except as specifically required by the Drawings and Specifications and after approval is granted by the Owner. Request approval five (5) working days in advance of the time that interruption of the existing system is required.
- E. A detailed sequence of construction shall be submitted by the Contractor and approved by the Architect / Engineer before any work is started. The City of West Park reserves the right to make changes to the sequence as necessary to facilitate the work or to minimize any conflict with operations. The hours of work shall be 7:30 a.m. to 5:00 p.m., Monday through Friday, with exception of holidays. All work outside these normal work hours shall be pre-approved by the City of West Park and all cost for overtime by the City.

## **1.5 USE OF PREMISES**

- A. Contractor shall confine construction equipment, the storage of materials and equipment, and the operations of workers to areas permitted by law, ordinances, permits, or the requirements of the Contract documents and shall not unreasonably encumber the premises with construction equipment or other materials or equipment. No storage of materials will be allowed on the site. Excavation must be removed from the site as it is dug. Materials will be brought to the site when needed.
- B. Contractor shall maintain roadways open to two way traffic at all times. Contractor shall backfill or steel plate, as directed by the Engineer, all trenches at the end of each workday so as to provide a surface passable by standard vehicular traffic.
- C. Contractor shall conduct his work in such a manner as to avoid damage to private or public property. Any damage to existing structures or work of any kind, including permanent reference markers or property corner markers or the interruption of utility service, shall be repaired or restored promptly at no additional expense to Owner.
- D. Contractor shall not enter upon private property for any purpose without first securing the permission of the property owner in writing and furnishing Engineer with a copy of said permission. This requirement will be strictly enforced, particularly with regard to such vacant properties that may be used for material storage.

- E. Contractor shall preserve and protect all existing vegetation such as trees, shrubs, and grass on or adjacent to the site that do not reasonably interfere with the construction, as determined by Engineer. Contractor shall be responsible for all unauthorized cutting or damaging of trees and shrubs, including damage due to careless operation of equipment, stockpiling of materials, or tracking of grass by equipment. Contractor shall be liable for, or shall be required to replace or restore at no additional cost to Owner, all vegetation that is destroyed or damaged.
- F. During the daily progress of the work, Contractor shall keep daily the premises free from accumulations of waste materials, rubbish, and other debris resulting from work. At the completion of the work, Contractor shall remove all waste materials, rubbish, and debris from and about the premises daily, as well as all tools, appliances, construction equipment and machinery, and surplus materials and shall leave the site clean and ready for occupancy by Owner. Contractor shall restore to their original condition those portions of the site not designated for alteration by the Contract Documents.
- G. Contractor shall not load or permit any part of any structure to be loaded in any manner that will endanger the structure, nor shall Contractor subject any part of the work or adjacent property to stresses or pressures that will endanger it.

**1.6 TEMPORARY CONSTRUCTION UTILITIES AND FACILITIES**

- A. The Contractor shall provide and maintain sanitary facilities for his employees and his subcontractors' employees that will comply with the regulations of the local and state Departments of Health and as directed by the Engineer. The Owner will provide a place of connection for temporary water, if required, for testing at the site, all fees for water service will be paid for by the Contractor. The Contractor shall provide all temporary piping required to bring the water to the point of use and shall remove the piping when no longer needed.
- B. The Contractor shall be responsible for obtaining a source of electric power for construction. All temporary electric power installation shall meet the construction safety requirements of OSHA, state, and other governing agencies. Cost of electric power shall be borne by the Contractor.

**1.7 SUBMITTALS DURING CONSTRUCTION**

- A. Requirements in this section are in addition to any specific requirements for submittals specified in other sections of the Contract Documents. Submittals shall be addressed to:

Project Manager-City of West Park  
1965 South State Road 7  
West Park-FL 33023  
\_\_\_\_\_

- B. Prior to the start of construction, the Contractor shall submit a detailed plan for the sequencing of his construction and proposed tie-in to the existing force main for review and approval.

- C. The Contractor agrees that shop drawing submittals processed by the Engineer do not become Contract Documents and are not Change Orders; that the purpose of the shop drawing review is to establish a reporting procedure and is intended for the Contractor's convenience in organizing his work and to permit the Engineer to monitor the Contractor's progress and understanding of the design.

#### **1.08 SHOP DRAWINGS REQUIREMENTS**

- A. Shop drawings referred to herein shall include both shop and setting drawings, proposed laying schedules, and other submittals for both shop and field-fabricated items. Submittals shall include but not necessarily be limited to:
  - 1. Concrete Mix
  - 2. Detectable Warning Surface
  - 3. Tree Root Barriers
- B. The submittals shall include satisfactory identification of items, units, and assemblies in relation to the specification.
- C. Should the Contractor propose any item on his shop drawings, or incorporate an item into the work, and that item should subsequently prove to be defective or otherwise unsatisfactory (regardless of the Engineer's preliminary review), the Contractor shall, at his own expense, replace the item with another item that will perform satisfactorily.

#### **1.09 RECORD DRAWINGS**

- A. During the entire construction operation, the Contractor shall maintain records of all deviations from the Drawings and Specifications and shall prepare therefrom "record" drawings showing correctly and accurately all changes and deviations from the work made during construction to reflect the work as it was actually constructed. Each month, or as otherwise agreed, the Contractor shall submit to the Engineer a current listing and description of each change incorporated into the work since the preceding submittal. These drawings shall conform to recognized standards of drafting and shall be neat and legible. Four (4) sets of certified "as-builts" shall be submitted to the Owner.

#### **1.10 PRECONSTRUCTION CONFERENCE**

- A. Within five (5) working days following execution of the Contract but before work at the site starts, the Contractor shall meet with the City of West Park and its Engineer for discussion of scheduling requirements, procedures for handling shop drawings and other submittals, for processing applications for payment, and to establish a working understanding among the parties as to the work.

### **PART 2 PRODUCTS**

**2.1 OWNER-FURNISHED ITEMS**

- A. There are no anticipated items to be furnished by the Owner for this project.
- B. If the Owner elects to furnish an item for this project, the Contractor's responsibility for material furnished by Owner shall begin at the point of its delivery to Contractor that is at the Owner's storage yard and not the project site. Materials already on the site shall become Contractor's responsibility on the day of the execution of the Agreement. Contractor shall examine all materials furnished by Owner at the time and place of delivery and shall call any defective material to the attention of Owner. Any material furnished by Owner and installed by Contractor without discovery of such defects will, if found defective prior to final acceptance of the work, be replaced with sound materials by Owner.
- C. Contractor, however, shall at his own expense furnish all supplies, labor, and facilities necessary to remove said defective material and install the sound material in a manner satisfactory to Engineer.
- D. All materials furnished by Contractor shall be delivered and distributed at the site by Contractor. Materials furnished by Owner shall be picked up by Contractor at Owner's storage yard, and then hauled to and distributed at the site.
- E. Payment for handling Owner-furnished material shall be included in the Bidder's applicable unit prices for installing the material.

**PART 3 EXECUTION**

- A. Not Used.

**END OF SECTION**



SECTION 01700 (01 70 00)

CONTRACT CLOSEOUT

**PART 1 - GENERAL**

1.01 SUMMARY:

- A. This Section includes administrative and procedural requirements for contract closeout including, but not limited to, the following:
  - 1. Inspection procedures.
  - 2. Project record document submittal.
  - 3. Submittal of warranties.
  - 4. Final cleaning.
  - 5. CONTRACTOR's Certification.
- B. Closeout requirements for specific construction activities are included in the appropriate Sections.
- C. Related Work Specified Elsewhere:
  - 1. Prerequisites to Substantial Completion and Final Acceptance: N/A

1.02 SUBSTANTIAL COMPLETION:

- A. Preliminary Procedures: Before requesting inspection for certification of Substantial Completion, complete the following as applicable:
  - 1. Submit specific warranties, workmanship bonds, , final certifications, and similar documents.
  - 2. Obtain and submit releases enabling the City unrestricted use of the Work and access to services and utilities. Include operating certificates, and similar releases.
  - 3. Submit record drawings, maintenance manuals, Project photographs, damage or settlement surveys, property surveys, and similar record information.
  - 4. Discontinue and remove temporary facilities from the site, along with mockups, construction tools, and similar elements.
  - 5. Complete final cleanup requirements, including touch up painting.
  - 6. Touch up and otherwise repair and restore marred, exposed finishes.
- B. Inspection Procedures: On receipt of a request for inspection, the City or its designee will either proceed with inspection or advise the CONTRACTOR of unfilled requirements. The City will prepare the Certificate of Substantial Completion following inspection or advise the CONTRACTOR of work that must be completed or corrected before the certificate will be issued.

1. The City will reschedule the inspection when in its opinion, the Work is substantially complete.

#### 1.03 FINAL ACCEPTANCE:

- A. Preliminary Procedures: Submit certification by CONTRACTOR that Work has been completed in accordance with the Contract Documents to the knowledge of the CONTRACTOR. Before requesting final payment, complete the following as applicable:
  1. Submit the request for final inspection and provide with any required releases and supporting documentation. Include insurance certificates for products and completed operations where required.
  2. Submit a certified copy of the City 's final inspection list of items to be completed or corrected. The certified copy of the list shall state that each item has been completed.
  3. Submit consent of surety to final payment.
  4. Submit evidence of final, continuing insurance coverage complying with insurance requirements.
  5. Release of Liens (from the Prime, and all CONTRACTORS, Vendors and Suppliers).
- B. Reinspection Procedure: The City will re-inspect the Work upon receipt of notice that the Work, including inspection list items from earlier inspections, has been completed.
  1. Upon completion of reinspection, the City will advise the CONTRACTOR of Work that is incomplete or of obligations that have not been fulfilled but are required for final acceptance.
  2. If necessary, reinspection will be repeated.

#### 1.04 RECORD DOCUMENT SUBMITTALS: (IF APPLICABLE)

- A. Maintain on site one set of the following record documents; record actual revisions to the work:
  1. Drawings/specifications, RFIs and addenda
  2. Change orders and other modifications to the contract
  3. Reviewed, approved and accepted shop drawings, product data, and samples
  4. Manufacturer's instruction for assembly, installation, and adjusting
- B. Ensure entries are complete and accurate, enabling future reference by Owner.
- C. Store record documents separate from documents used for construction.
- D. Record information related to changes of approved construction documents concurrent with construction progress.
- E. Specifications - legibly mark and record at each product section a description of the products

installed.

1. Manufacturer's name, product name and model number
  2. Changes made by addenda and modifications
- F. As-Built Drawings and shop drawings - legibly mark each item to record actual construction.
1. Measured horizontal and vertical locations of underground utilities and appurtenances, referenced to permanent surface improvements.
  2. Field changes of dimension and detail.
  3. Provide any additional details not on original contract drawings.
- G. As-built survey/Flood Certification Form:
1. Upon completion of site construction improvements, provide Architect and Owner with a complete and accurate field survey prepared, signed and sealed by a Florida registered surveyor.
- H. Submit documents, AutoCAD files, and PDF files on a CD.

## **PART 2 - EXECUTION**

### **2.01 FINAL CLEANING:**

- A. General: The GENERAL CONDITIONS require general cleaning during construction.
- B. Cleaning: Employ experienced workers or professional cleaners for final cleaning. Clean each road surface to the condition expected in a normal program. All residual aggregate, sand or other road and drainage materials shall be removed to the satisfaction of the Town before final payment is approved.
1. Complete the following cleaning operations before requesting inspection for certification of Substantial Completion.
    - a. Remove debris and surface dust from limited-access spaces including trenches, equipment vaults, manholes, and similar spaces.
    - b. Clean the site of rubbish, litter, and other foreign substances. Rake grounds that are neither paved nor planted to a smooth, even-textured surface.
    - c. Remove temporary structures, tools, equipment, supplies, and surplus materials.
    - d. Remove temporary protection devices and facilities which were installed to protect previously completed Work.
    - e. Special Cleaning: cleaning for specific units of Work is specified in applicable Sections of Specifications.
- C. Removal of Protection: Remove temporary protection and facilities installed for protection of the Work during construction.
- D. Compliance: Comply with regulations of authorities having jurisdiction and safety standards for cleaning. Do not burn waste materials. Do not bury debris or excess materials. Do not discharge volatile, harmful, or dangerous materials into drainage systems. Remove waste materials from the site and dispose of lawfully.

E. Repairs:

1. Repair damaged protective coated surfaces.
2. Repair roads and other items damaged or deteriorated because of construction operations, including those which have been damaged, but are not located within the project limits.
3. Restore all ground areas affected by construction operations.

END OF SECTION

LEGEND:

 SIDEWALK/RAMP RESTORATION/ADA ZONES FOR PHASE 2 PROJECT AREAS

 CENSUS TRACT

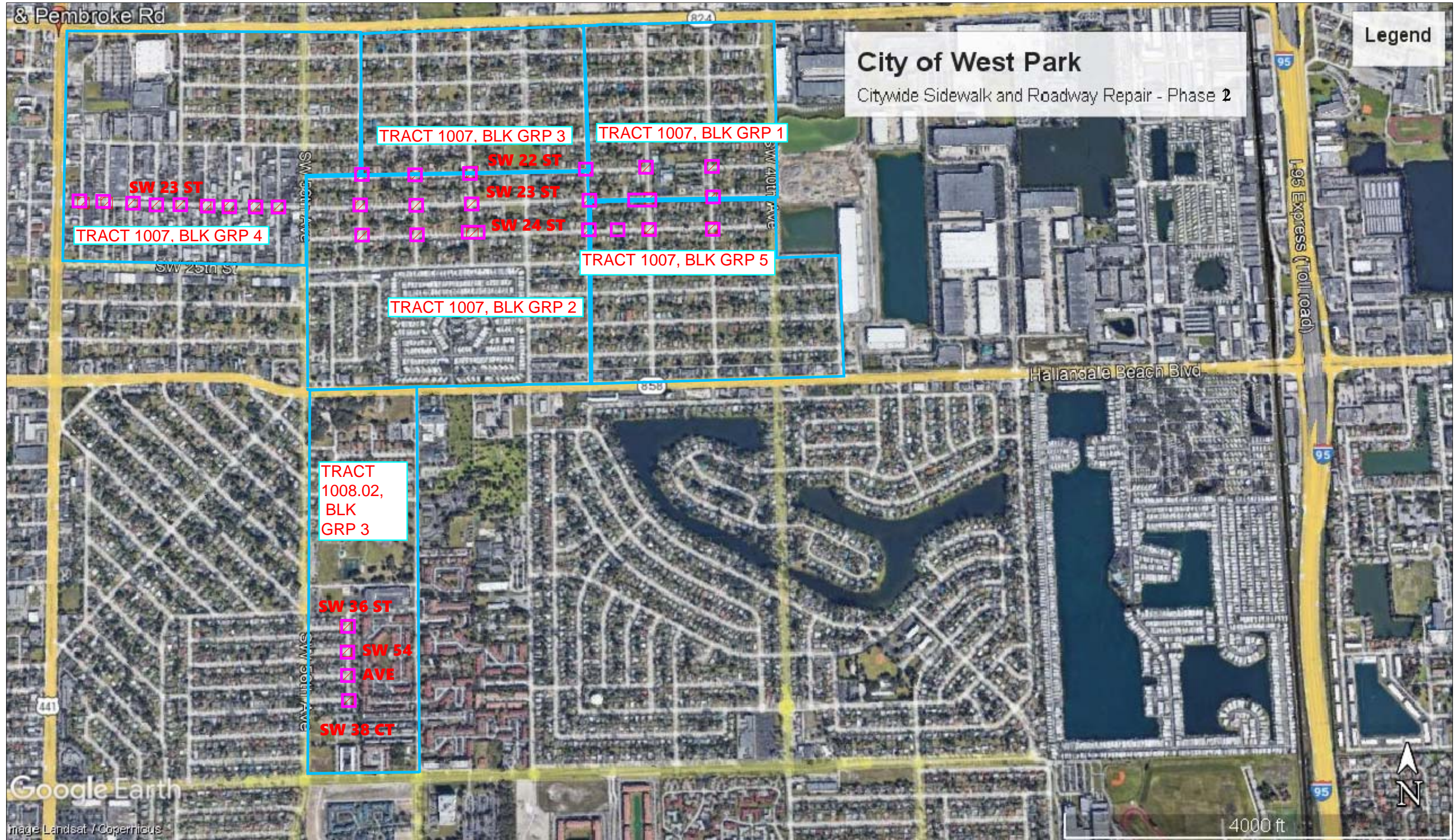

- NOTES: 1. PLAN NOT DRWN TO SCALE  
 2. AREAS IDENTIFIED MAY NOT RELECT ALL LOCATIONS WITHIN THE CITY REQUIRING ADJUSTMENT  
 3. PLAN BASED ON FIELD INVESTIGATIONS THROUGH MARCH 2023 (ANY DAMAGED AREAS IDENTIFIED AFTER THIS DATE MAY NOT BE REFLECTED)

# ATTACHMENT 1

REVISIONS		
DATE	BY	DESCRIPTION

CITY OF WEST PARK  
FLORIDA

CITYWIDE SIDEWALK RESTORATION & ADA - PH 2

# ATTACHMENT 2

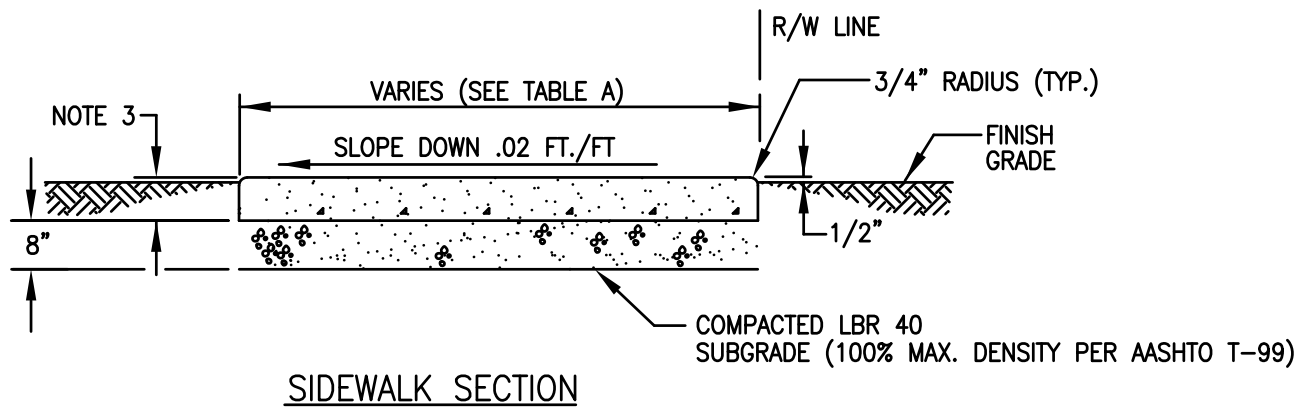
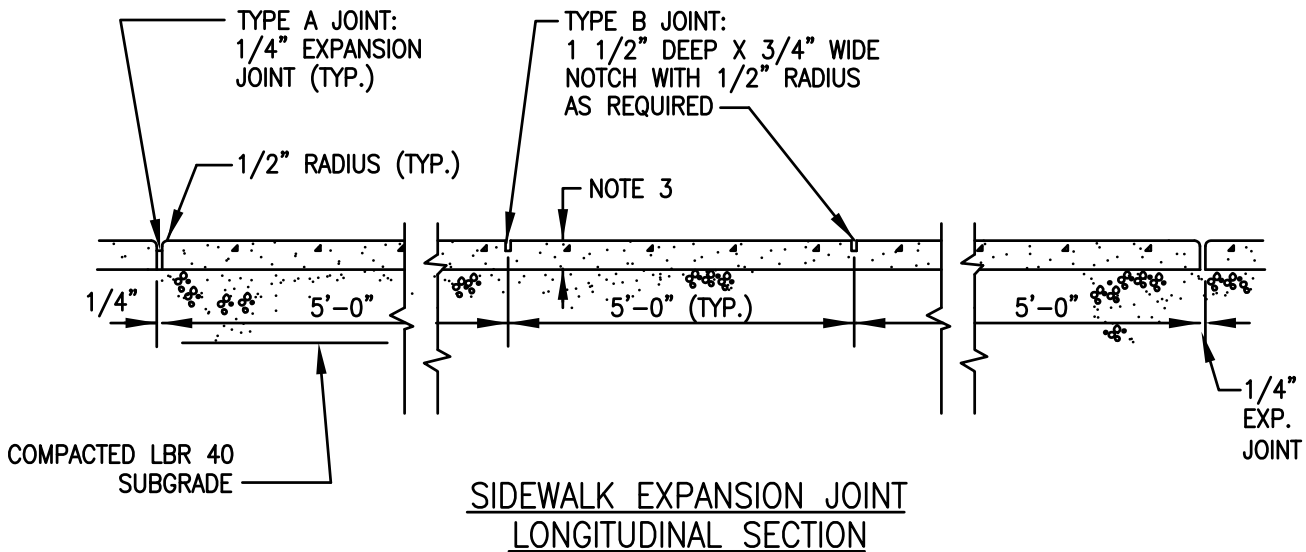

**NOTES:**

1. CONCRETE TO BE CLASS 1, 3,000 P.S.I.
2. 4" THK. MIN. (TYP.); 6" THK. AT DRIVEWAYS, EXTENDED TWO-FOOT BEYOND DRIVE, ON BOTH SIDES.
3. SIDEWALK SLOPES AND HORIZONTAL CLEARANCES SHALL MEET THE REQUIREMENTS OF THE AMERICAN WITH DISABILITIES ACT (ADA).
4. PEDESTRIAN RAMPS SHALL INCLUDE A DETECTABLE WARNING SURFACE PER FDOT INDEX 304.
5. CONSTRUCT EXPANSION JOINTS AT SPACINGS SHOWN ABOVE; AT POINT OF CURVATURE; AT ADJOINING STRUCTURES; AT THE END OF DAYS WORK; AND WHERE NEW SIDEWALK MEETS EXISTING SIDEWALK.
6. STAMPED CONCRETE IS NOT ALLOWED IN LIEU OF TRUNCATED DOMES.

SIDEWALK JOINTS	
TYPE	LOCATION
"A"	P.C. P.T. OF CURVES
"B"	5'-0" CENTER TO CENTER ON SIDEWALKS

## **ATTACHMENT 3**

### **SCOPE OF SERVICES / TECHNICAL SPECIFICATIONS**

#### **3.1 SCOPE OF WORK**

The City has issued this Solicitation to secure qualified, licensed and experienced Contractor(s) to provide replacement of damaged or deteriorated concrete sidewalk along with ADA intersection ramp upgrades and associated tree root barrier and swale restoration. Installation should include all labor, supervision, materials, Maintenance of Traffic ("MOT"), root pruning, and restoration of all the areas abutting the repaired sidewalks.

#### **3.2 LOCATION**

All ramp modifications and sidewalk repairs will be based on specific locations marked in field and authorized by the city along the following corridors:

- *SW 22<sup>nd</sup> Street*
- *SW 23<sup>rd</sup> Street*
- *SW 24<sup>th</sup> Street*
- *SW 54<sup>th</sup> Avenue from SW 36<sup>th</sup> Street to SW 38<sup>th</sup> Court*

#### **3.3 REPLACEMENT CONCRETE SIDEWALK**

Sidewalk repair as well as concrete for driveway/driveway approaches and ramp areas shall be six inches (6") thick. Incidental concrete curb repair shall be as directed by city. All formwork shall be inspected by city prior to concrete placement.

All sidewalk that the City has determined to be replaced due to deterioration, cracking, uplifting, improper sloping, misalignments, grade, etc. will be removed and replaced as required or as otherwise instructed by the City. Removal of existing sidewalk shall be performed by saw cutting the section of unacceptable sidewalk (as determined by the City) at the nearest acceptable five-foot (5') flag and new sidewalk shall be poured in its place as established by specifications. All areas where existing sidewalk is to be replaced must be prepared and graded to match adjacent sidewalk flags and all replacement sidewalk sections shall be installed to match the existing sidewalk elevation. For areas where existing tree roots have uplifted sidewalk, roots shall be pruned and removed, and if necessary, tree root barriers shall be installed per manufacturer's specifications prior to sidewalk re-installation.

Concrete shall not be poured, installed or place around manholes, cleanouts, or other structures until they are at required elevations and alignment. Contractor shall notify the City in writing of manholes, cleanouts, or other items that may require relocation or modification prior to placement.

Sidewalk will also include sidewalk curb ramps with detectable warning surface per FDOT Index 304 where applicable. Construct forms for this work of either wood or metal. Provide forms that are straight, free from warp or bends, and of sufficient strength, when staked, to resist the pressure of the concrete without deviation from line and grade. For all items constructed on a radius, use flexible forms.

Compact fill areas, including cut areas under the sidewalk that have been excavated more than 6 inches below the bottom of sidewalk, to a minimum of 95% of AASHTO T99 density. The area to be compacted is defined as that area directly under the sidewalk and 1 foot beyond each side of the sidewalk when right-of-way allows.

Place the concrete in the forms, and tamp and spade it to prevent honeycombing, and until the top of the structure can be floated smooth. Strike-off the concrete by means of a wood or metal screed, used perpendicular to the forms, to obtain the required grade and remove surplus water and laitance. *Provide a broom finish.* Ensure that the surface variations are not more than 1/4 inch under a 10 foot straightedge or more than 1/8 inch on a 5 foot transverse section. Finish the edge of the sidewalk with an edging tool having a radius of 1/2 inch.

Concrete mixes shall be 3,000 psi from and FDOT approved from an FDOT approved supplier. Documentation shall be approved for use on the Project by the City at least seven (7) days prior to placement. Moreover, all concrete delivery tickets shall contain the approved mix number, and be available for review on site and submitted to the City prior to approval for payment. The Weather protection shall be available on site during all concrete placement operations.

### **3.4 CLEARING AND GRUBBING**

This work includes sawcutting, removal of and disposal of miscellaneous concrete, asphalt, rocks, vegetation, tree roots, debris, and pipes, and other facilities not covered under separate items, as necessary to prepare the area for the proposed construction. Includes the cost for clearing and grubbing within harmonization areas and preparation for sod/grass and other materials to prepare the ground for sidewalk installation. Contractor shall take all reasonable precautions to prevent damage outside public right of way. Excess material, including demolished material, roots from trees, excess earth and excess building materials are property of the contractor and shall be removed from site daily and legally disposed of.

All form work and site preparation shall be conducted with minimum impact and/or damage to the adjacent properties. Those areas disturbed as a consequence of sidewalk installation and those areas disturbed as a consequence of Contractor mobilization and stock piling shall be restored promptly at **Contractor's expense**. The Contractor shall not utilize methods of mobilization or execution of work that impacts private/public areas excessively and/or in a manner that is unacceptable to the City. Contractor shall ensure that all private and/or public areas impacted by the mobilization, stock piling, or lack of coordination as interpreted by the City are restored at no cost to the City.

Prior to clearing, demolition, or other construction activities, maintenance of pedestrian and vehicular traffic, and protective barriers shall be constructed, as necessary, and inspected by the City to prevent the destruction or damaging of private property, mailboxes, and landscaping from any construction activity or storage of equipment and materials.

### **3.5 INSPECTIONS**

The City shall conduct inspections of the site before Work begins and/or during clearing, construction and/or post-construction phases in order to ensure compliance with City standards and the scope of work. The formwork for all concrete work must be inspected by the City prior to

the placement. A final inspection shall be conducted after the concrete has been placed. Inspections shall be made to verify appropriate compaction of subbase and to check forms for line and grade. If any concrete is found to be installed improperly, the Contractor will be required to remove and replace promptly at no cost to the owner.

### **3.6 MAINTENANCE OF TRAFFIC**

The Contractor(s) shall supply whatever MOT is necessary to provide protection to both the workers on the job site and the public utilizing the adjacent public facilities. Maintain traffic within the limits of the project for the duration of the construction period, including any temporary suspensions of the work. Construct and maintain detours. Provide facilities for access to residences, businesses, etc., along the project. Furnish, install and maintain traffic control and safety devices during construction. Furnish and install work zone pavement markings for maintenance of traffic (MOT) in construction areas. Provide any other special requirements for safe and expeditious movement of traffic. MOT includes all facilities, devices and operations as required for safety and convenience of the public within the work zone.

When the Contractor(s) is working adjacent to the travel lanes, the Contractor shall provide an adequate buffer zone between workers and motor vehicles. The Contractor(s) shall furnish, set up, and continuously maintain all MOT equipment and devices in accordance with FDOT index 102.

Contractor shall coordinate work to ensure that pedestrian access and access to driveways and adjacent properties are available at all times. Contractor shall ensure that all sites are clean, and secure as required, and acceptable prior to mobilizing to other locations. The Contractor shall replace any sod, concrete and/or asphalt removed, damaged or displaced during demolition or performance of work at Contractor expense

### **3.7 EROSION AND SEDIMENT CONTROL**

The Contractor(s) is responsible for erosion, sediment, and water turbidity control practices during construction to control on-site erosion/sedimentation and shall, at a minimum, employ the following practices:

- Erosion, sediment, and turbidity control are the responsibility of the Contractor and must be in place prior to the start of construction. These delineated measures are the minimum required, with additional controls to be utilized as needed, dependent upon actual site conditions and construction operation.
- All erosion, sediment and turbidity control measures shall be maintained in working order throughout the construction phase. The Contractor shall inspect and repair as necessary the erosion/sedimentation protection and alter or increase the control measure as necessary to meet the control requirements.
- All stormwater sewer system inlets immediately adjacent to work zone shall have sediment inflow prevention facilities in place as per State of Florida standards throughout the construction phase.

Due to unanticipated conditions, the Engineer may direct the use of control features or methods other than those included in the original Contract.

### **3.8 DETECTABLE WARNINGS**

Furnish and install cast-in-place detectable warnings on newly re-constructed concrete walking surfaces (sidewalk curb ramps, sidewalks, etc.) constructed in accordance with the FDOT Design Standards, Index No. 304.

Provide detectable warnings in accordance with the Americans with Disabilities Act Standards for Transportation Facilities, Section 705. Use detectable warnings consisting of materials intended for exterior use subject to routine pedestrian traffic and occasional vehicular traffic. Use detectable warnings comprised of truncated domes aligned in parallel rows in accordance with the FDOT Design Standards, Index No. 304. Do not cut through the middle of truncated domes. Use safety yellow-colored detectable warnings on concrete walking surfaces with a Light Reflectance Value (LRV) CAP Y\* of 25-45 (*\*When measured with a spectrophotometer*).

Use detectable warnings listed on the Florida Department of Transportation's Approved Product List (APL). Install in accordance with the manufacturer's instructions, using materials and equipment recommended and approved by the manufacturer. Clean up excess concrete from tile. Shop drawing approval required.

### **3.9 SODDING**

The Contractor is responsible for replacing and re-establishing/watering all sod disturbed during construction with St. Augustine. The sod shall be installed within a week of sidewalk installation/repair as necessary. Place the sod on the prepared surface, with edges in close contact. Do not use sod, which has been cut for more than 48 hours.

### **3.10 SUPPLEMENTAL SPECIFICATIONS**

Please see Attachments for Typical Sidewalk Detail Specifications.

### **3.11 PROJECT COORDINATION**

Upon Issuance of a NTP the Contractor(s) will conduct a pre-construction site visit with City representatives in order to confirm and mark the locations to be repaired/upgraded. The purpose of this activity is to ensure the work to be performed falls within the intended scope and allocated budget. Locations and quantities may be adjusted at the discretion of the City. Sidewalk repair locations shall be given priority status over ramp reconstruction.

**END OF SECTION**